



"18 '17  
21

# EDUCATIONAL WOODWORK.

A Text Book for the use of Instructors and Students  
in Elementary and Secondary Schools,

By A. C. FORTH.

(Member of the Art and Manual Training Department, Roan School  
for Boys, Greenwich.)

CONTAINING

A THREE YEARS' COURSE OF WOODWORK, DRAWING,  
AND OBJECT LESSONS, AND CHAPTERS ON DISCIPLINE,  
ORGANISATION AND METHOD, FITTINGS AND FUR-  
NITURE, AND THE INSTRUCTION OF THE DEAF,  
BLIND, AND SPECIAL CHILDREN.

*With nearly 200 illustrations.*

---

NEW YORK :

SPON & CHAMBERLAIN, 123-125 LIBERTY ST.

1905

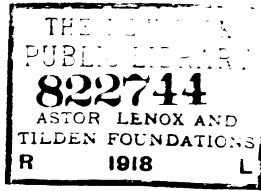

## CONTENTS.

	Page.
FIRST YEAR COURSE . . . . .	7
SECOND YEAR COURSE . . . . .	44
THIRD YEAR COURSE . . . . .	72
FITTINGS AND FURNITURE . . . . .	98
DISCIPLINE . . . . .	106
ORGANIZATION AND METHOD . . . . .	112
THE INSTRUCTION OF THE PHYSICALLY AND MENTALLY DEFICIENT AND BLIND	120
OBJECT LESSONS ON THE BLACK BOARD	130

Ref. 371.42  
H4

P R E F A C E .  
PROPERTY OF THE  
CITY OF NEW YORK

THE object of this work is to provide a graduated educational course of woodwork, based on a succession of joints, with a model following each joint, and, as far as possible, based on it.

Special chapters are given on the discipline, method, organisation, and fittings necessary for the carrying on of the work on broad and educational lines.

A section is devoted to the manual training of the Deaf, Blind, Physically or otherwise deficient children, with a suggested course of woodwork suitable for them. The general course given in this book has been successfully carried out by the author at the King Edward VI. Grammar School, Retford, and also at the Roan Secondary School, where the models suggested in the third year's course have been found to be of considerable value to the science section of this large and important school. A complete scheme of object lessons, with specimen blackboard illustrations is also given.

The author is greatly indebted to Messrs. J. Scott Knight and J. B. Joyce for their valuable help in revising the manuscript and proofs; also to Mr. C. W. Winter, of the Hugh Myddleton Deaf Centre, for the drawings of the strip work course designed by him.

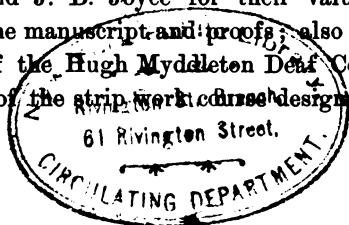

A. C. H.

36723

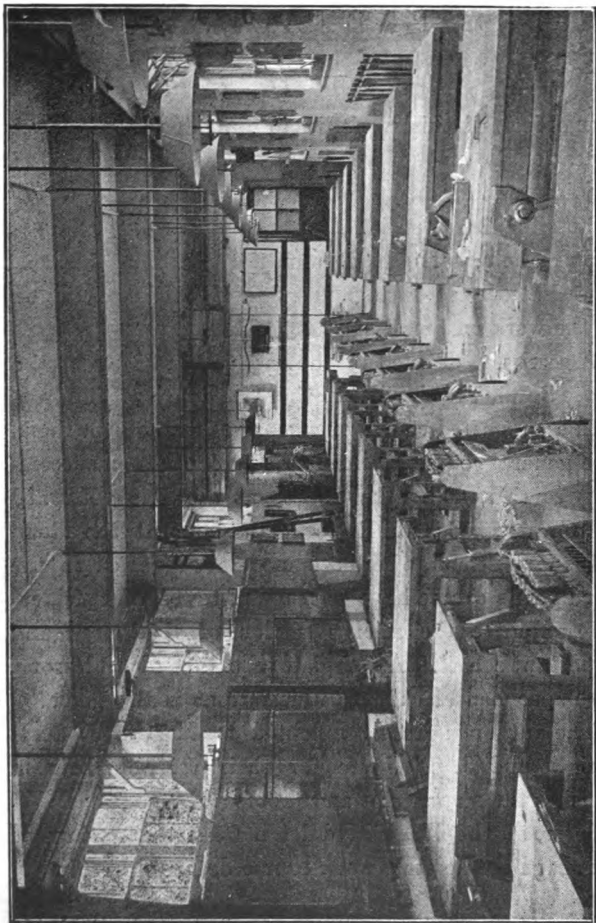

**AN EDUCATIONAL WORKSHOP.**

# Educational Woodwork.

---

## FIRST YEAR COURSE.

---

### EXERCISE 1.

#### Sawing with Tenon Saw. (FIG. 1)

**DRAWING: Materials.**—Paper or book, 12in. box-wood ruler, 45 deg. and 60 deg. set squares and H pencil.

**Teaching Method.**—Show on hinged blackboard the two projections (Fig. 2), using a block of wood double size, and explain the position of XY; then have a line drawn across the paper to represent it, next mark off a distance below for base line, and after marking off from the centre of XY, half the length of the wood each way, draw the upright lines. Here great care must be taken to see that the square and rule are properly held. The distances from the XY should now be marked from the given sizes and then the horizontal lines drawn. This gives the projections of a plain block of wood 10in. by 2in. by 1in., and to complete the drawing the

sizes shown in Fig. 1 must be marked off on one line, and drawn with the set square, ruler and pencil held as in Fig. 3.

At the end of lesson the isometric (iso-equal, metric-measurement) projection may be attempted as in Fig. 4.

**BENCHWORK: Materials.**—A piece of wood 12in. long should be cut from a planed 2in. by 1in. yellow deal batten and given to each boy, who should also have a sawing board (Fig. 6) tenon saw,  $4\frac{1}{2}$ in. try square, steel rule and marking knife.

*Teaching Method.*—Draw the attention of the class to the face marks (Fig. 5), and show the correct method of holding try square and marking knife (Fig. 7), and commence by marking off a line  $\frac{1}{4}$ in. from end and carry it round, keeping the square either on face side or edge. This end must now be sawn off square. Fig. 8 shows the correct method, with the eyes over the saw and the boy standing well back from the bench. The whole length of the saw blade should be used, and with the handle grasped firmly the cuts should be deliberately made. The first attempt may be a failure, but by standing the block on the sawn end the boy will see the amount of his error, and will make another attempt. When this end is square repeat the process at the other. This should leave a piece of wood at least 11 inches long.

At this stage explain that the sawcut has a certain thickness, and if the piece of wood which is being

<p>FIG. 1.</p>	
<p>FIG. 2.</p>	<p>FIG. 4.</p>
<p>FIG. 3.</p> <p>Position of fingers in holding rule &amp; set-square.</p>	<p>FIG. 5.</p> <p>A - Proper side of line for sawing ends off pieces - B</p>

EXERCISE 1.



cut up is 10in. long and 4 cuts made in it, the pieces would then be less than 10in. Great care must be taken that each piece cut off measures the exact size. Start by marking off the  $\frac{1}{2}$ in. piece, and then,

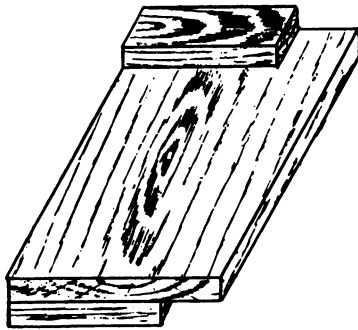

FIG. 6.

placing the saw just outside the line, saw it off (Fig 5). The other pieces should be sawn off in the same manner, and if care has been taken, they will measure 10in. when placed together, and a fair command of the tools used will be gained.



FIG. 7.

FIG. 8.

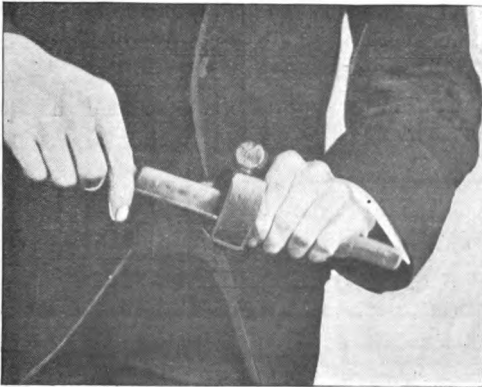

FIG. 12.

**EXERCISE 2.****Paring with the Chisel (Fig. 9).**

**DRAWING: Materials.**—Same as Exercise 1.

**Teaching Method.**—This drawing is only a little more difficult than the previous one, the method being the same. The upright isometric drawing of the block (Fig. 10) should be made.

**BENCHWORK: Materials.**—A piece of planed batten 11in. long, tools as in Exercise 1, plus a marking gauge and  $\frac{5}{8}$ in. Firmer chisel.

**Teaching Method.**—Commence by marking off and sawing to size, 10in., and then mark off the grooves with a marking knife on the face and lightly down each edge, and then set the marking gauge (Fig. 12) to the depth of grooves (Fig. 9). The actual gauging is an operation which although easy, requires a lot of care, and attention must be paid to Fig. 13. The stock must be kept close to face side or else the spur will run with the grain. Fig. 14 shows how gauging may be taught in motions: 1st, by running the gauge along without making a mark; 2nd, by repeating the movement with the spur lightly touching the wood; 3rd, by finishing with the spur a little deeper.

If these directions are carefully carried out no great difficulty will be experienced. When both edges of the wood are gauged, the sides of one groove should be sawn, attention being drawn to Fig. 5 to avoid mistakes in sawing.

FIG. 9.

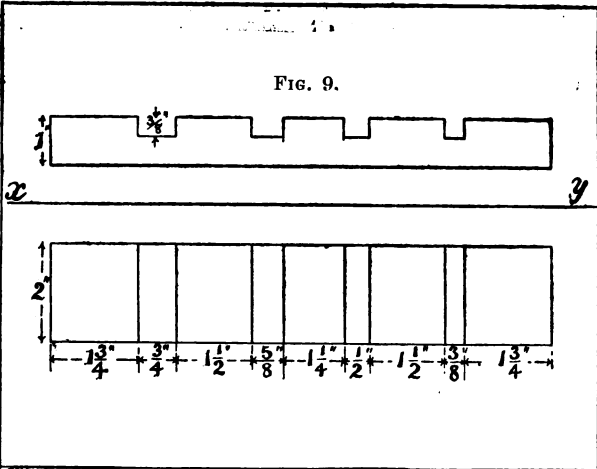

FIG. 11.

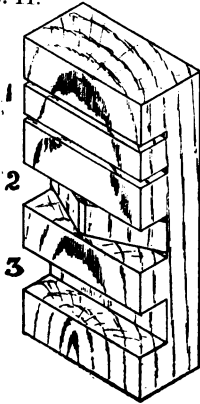

FIG. 10.



The wood must now be placed in the vice, and with the chisel firmly held in the right hand, the boy should take up the position shown in Fig. 15, and take thin parings down to the nearest gauge-line and halfway at the top (Fig. 11), and then reverse the wood and

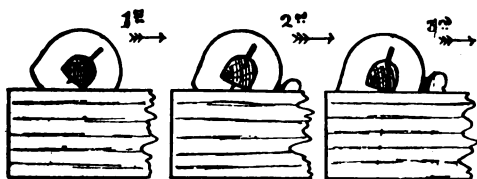

FIG. 14.

finish to other gauge-line with horizontal cuts, testing when the line is reached with the edge of try square. The same method is followed in cutting the other grooves.

This exercise gives further practice with the saw, and introduces the gauge and chisel.

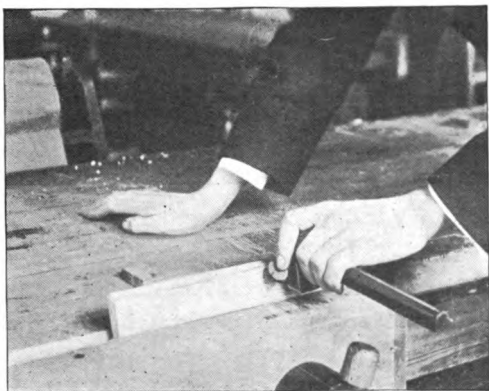

FIG. 13.

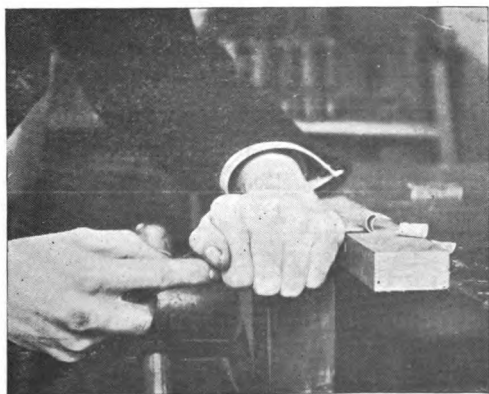

FIG. 15.

**EXERCISE 3.****Grooves of Varying Widths and Depths.** (FIG. 16).

**DRAWING.**—The difficulty is only slightly increased, and another isometric view of the block A is given (Fig. 17), also oblique projections in two positions (Figs. 18, 19).

**BENCHWORK: *Materials.***—Planed deal batten 11in. long, and  $\frac{7}{8}$ in.,  $\frac{3}{8}$ in. and  $\frac{1}{4}$ in. Firmer chisels.

***Method.***—This exercise contains no new operations, and if care is taken in the gauging it should be done accurately. Each groove should be finished separately, and carefully tested and measured when finished.

With a class of older boys the wood for this exercise may be planed by the boys themselves, but with smaller boys it is better to leave it until either Exercise 4 or 5.

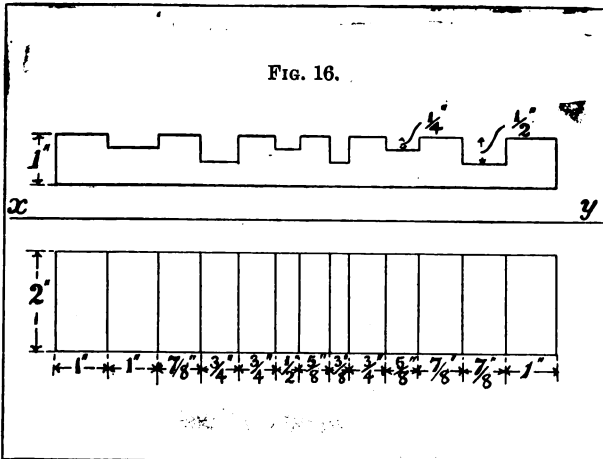

Fig. 17.

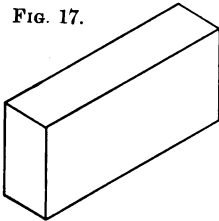

Fig. 19.

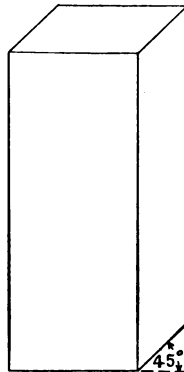
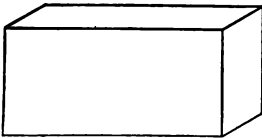

Fig. 18.



Oblique projection of A.

Oblique projection of A.



**EXERCISE 4.****Exercise in Vertical Paring.** (FIG. 20).

**DRAWING.**—A simple isometric projection is given (Fig. 21), as well as the drawing of the exercise.

**BENCHWORK: *Materials.***—Planed or unplaned batten 11in. long.

***Method.***—The gauge-lines in this exercise are more difficult, but with the practice gained in the previous exercises they should be well done. Fig. 22 shows the best way of holding wood and gauge, and the same method (Fig. 14) used as in edge-gauging. After the grooves are marked out, place the wood on a paring board, hold chisel as shown in Fig. 23, and pare with thin shavings down to the proper depth. Repeat this in the case of all the grooves, finishing one at a time.

FIG. 20.

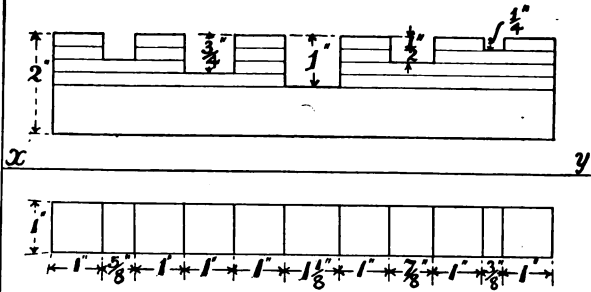
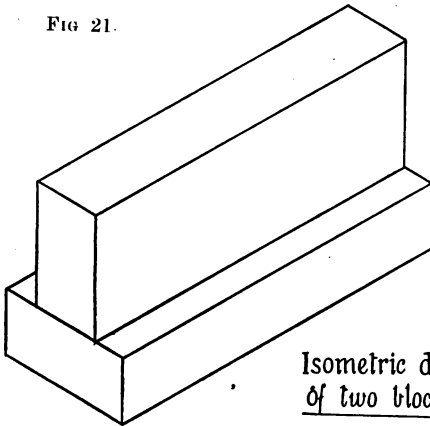

FIG 21.



Isometric drawing  
of two blocks A.

EXERCISE 4.

**EXERCISE 5.****Housing Joint.** (FIG. 24).

**DRAWING.**—A side elevation of this exercise is given, and the isometric projection of the grooved piece is set as a drawing exercise (Fig. 25).



FIG. 22.

**BENCHWORK :** *Materials.* — Unplaned basswood batten, 11in. by 2in. by 1in., jackplane, mallet, hammer, and straight edge.

*Method.*—If the previous exercises have been worked in planed wood, the practice and confidence gained

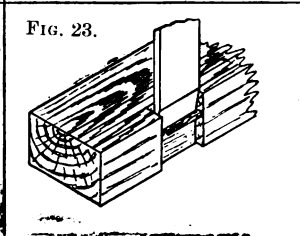
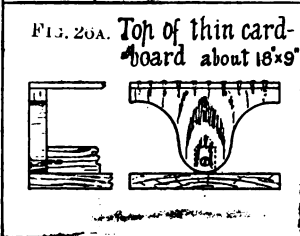
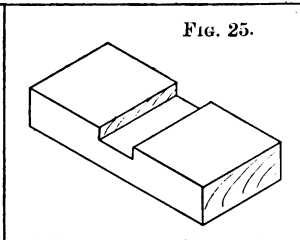
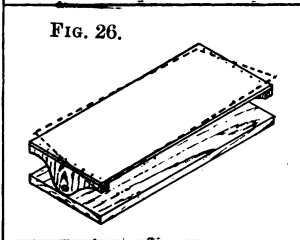
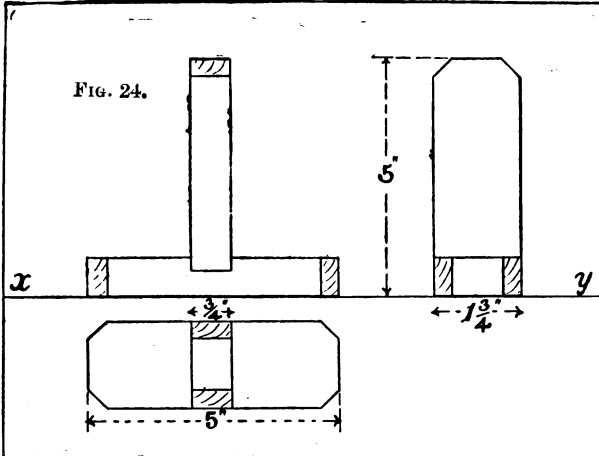

will be of great value when commencing planing. The action and parts of the plane should be first explained, and each boy should take apart and set his plane before being allowed to use it. Figs. 27, 28, 29, show the best method of doing this, and when each plane is



FIG. 27.

properly set the boy should stand just behind his wood with his feet well apart, and holding the plane as in Fig. 30. There are several methods of planing, but it is better to teach a straight firm stroke right along the wood, and test as soon as the surface is

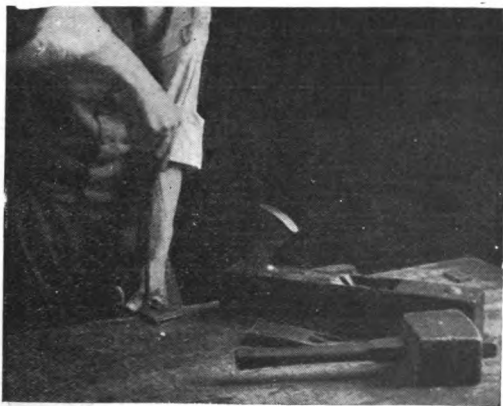

FIG. 28.

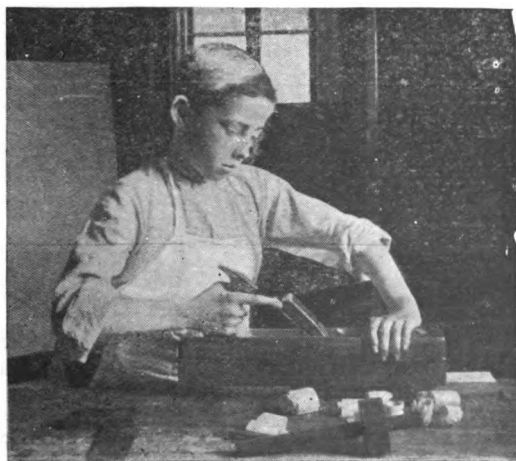

FIG. 30.

smooth with the straight edge, placed across the diagonals and from end to end (Fig. 38), and also with try square (Fig. 31). Care must be exercised that the surface is quite true, and the use of an apparatus like Fig. 26 will probably be found very useful; the



FIG. 29.

general tendency in planing is to get the opposite corners too low, and if those corners of the apparatus are pushed down, the same error as that on the wood is shown exaggerated, and the remedy suggested by slightly pressing on the highest corners until the surface is level.

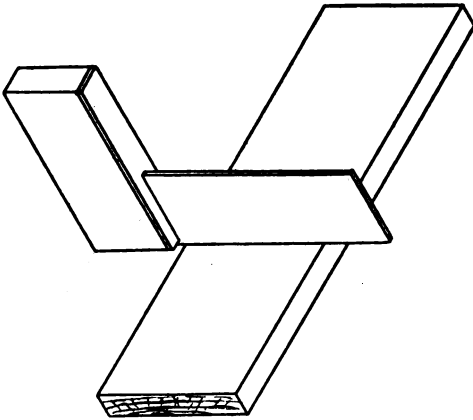

FIG. 31.

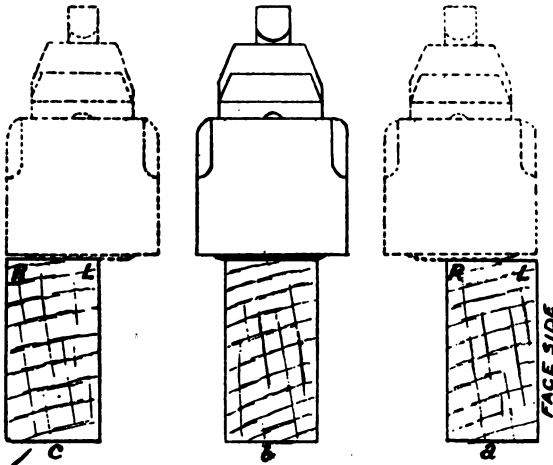

FIG. 33.



When the surface is quite true the face mark should be put on, and the nearest edge to the mark planed. (It is usual to mark the right-hand edge as it lies on the bench.) When the wood is thick enough it may be planed against the stop, but if not, placed in the vice.

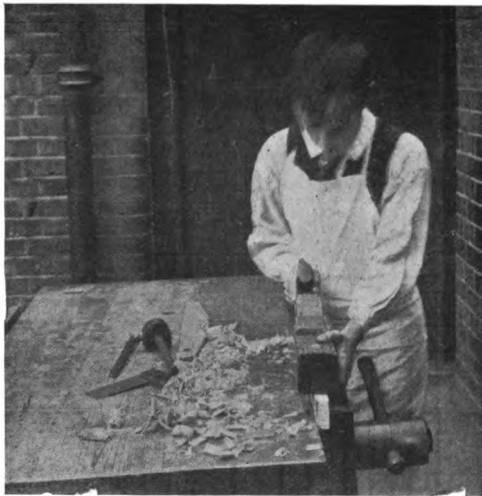

FIG. 32.

Hold the plane for edge planing as in Fig. 32, the fingers being underneath to form a gauge. Fig. 33 will explain the way in which a shaving may be taken off one edge without touching the other; "a" shows the cutting iron on the right-hand side, leaving no iron on

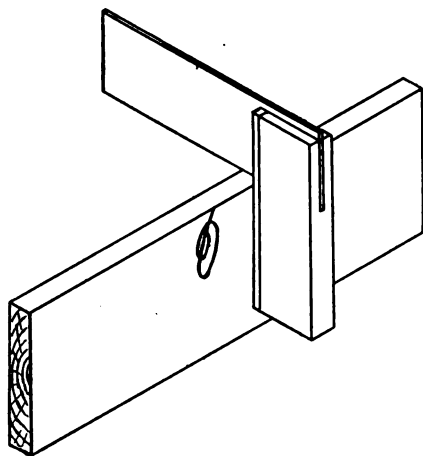

FIG. 34.

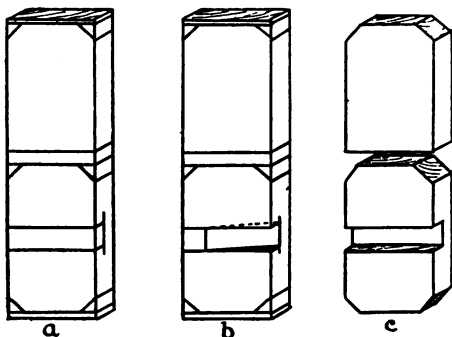

FIG. 35.

the left; a shaving would come off the whole width if the plane were held as at "b," and the order is reversed at "c." The tests for the edge should be with the straight edge and try square (Fig. 34); when finished place the mark on, and this leaves the wood ready for gauging to width. Set the gauge to  $1\frac{3}{4}$  in. and gauge as in Fig. 22,

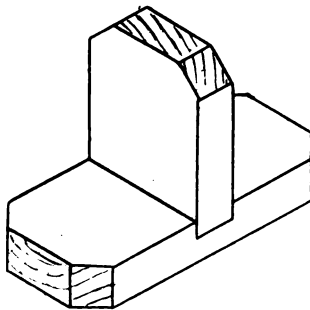

FIG. 36.

then plane to the line, testing after every few shavings as in Fig. 34. The last operation is planing to thickness. Gauge as in Fig. 13 on both edges, and carefully plane to both lines, using the try square held as in Fig. 31 for a test.

The completion of the model is only a matter of careful marking out and sawing. Fig. 35 shows order of work and Fig. 36 the finished exercise; no difficulty should be experienced in this part of the work. The corners are, of course, pared vertically with a wide chisel (Fig. 37).

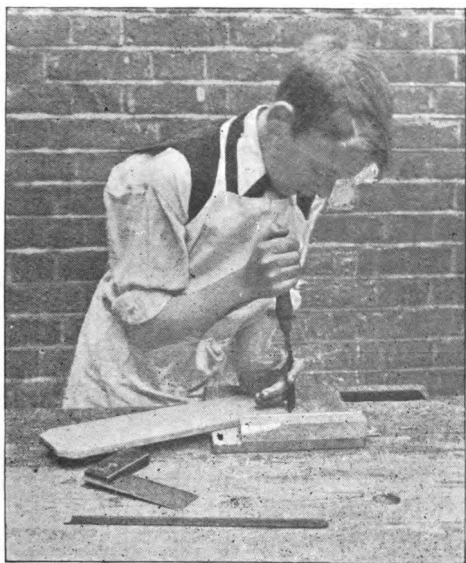

FIG. 37.

**EXERCISE 6.****A Letter Rack.** (FIG. 39).

**DRAWING.**—This should not prove more difficult than previous drawings. The plan, front and side elevation are given, and one of the upright pieces (Fig. 41) is given as an extra drawing exercise.

**BENCHWORK: Materials.**—Basswood 15in. by  $3\frac{1}{4}$ in. by  $\frac{5}{8}$ in., and wide chisel  $1\frac{1}{4}$ in.; bradawl and some  $\frac{3}{4}$ in. brads.

**Method.**—The wood must be accurately planed to size, and then the marking-out carefully done; commence by marking-off a little waste, then one of the short uprights, then a little more waste, and the middle upright, more waste, and the third space will be taken up with the base, and leaving just enough for the other upright (Fig. 40). The three grooves must be marked on the base, and their depths carefully gauged to  $\frac{1}{2}$ in.; now saw the sides of the grooves with the wood lying on the sawing board, and afterwards place in the vice and pare the waste out. In holding it in the vice the value of the long length of wood will be felt, and which should only be cut into pieces when the grooves are finished. Carefully mark the corners where they are to be taken off, and holding the chisel vertically, pare gradually down the line. To fix together, put the shorter pieces in their places, and turning the wood upside down, bore just through the base with a fine bradawl (Fig. 42), about  $\frac{1}{2}$ in. away from each end, and drive in a brad, afterwards doing the same with the middle piece.

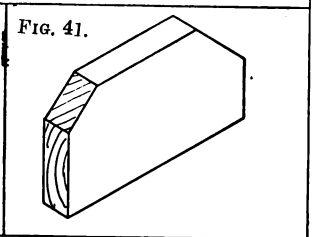
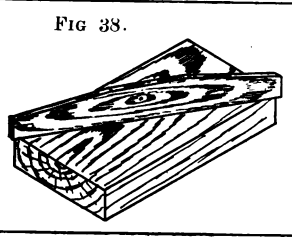
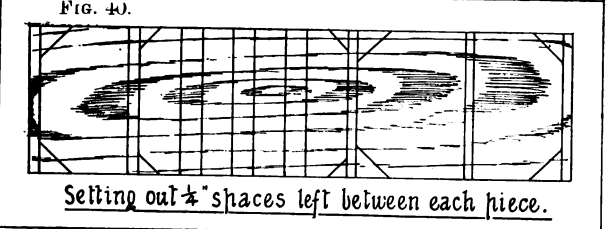
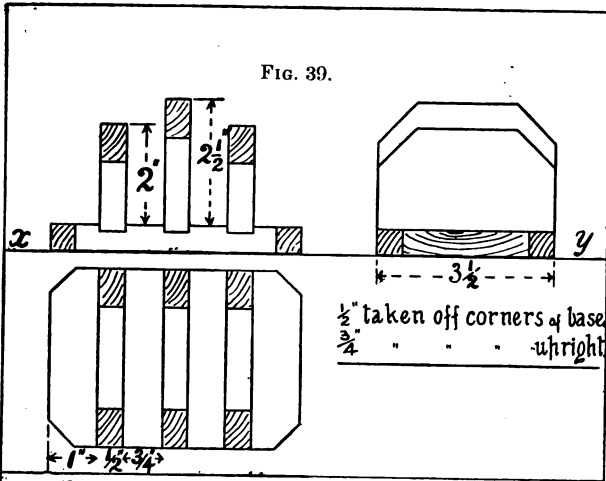

EXERCISE 6.

**EXERCISE 7.****A Cross Halving Joint. (FIG. 43).**

**DRAWING.**—Plan, sectional elevation, and side elevation, with change of ground line, and isometric projection (Fig. 44).

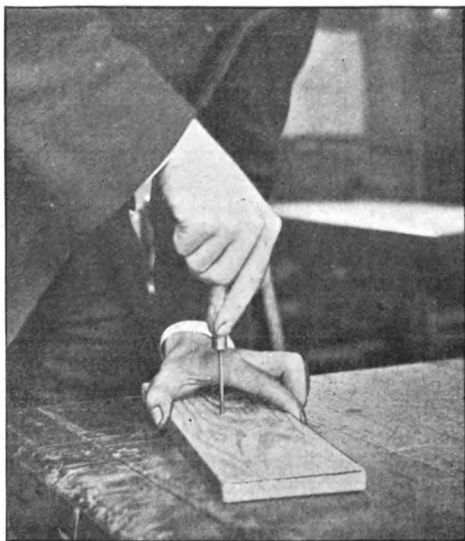
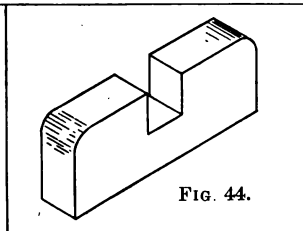
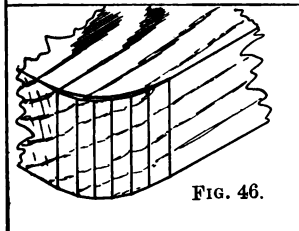
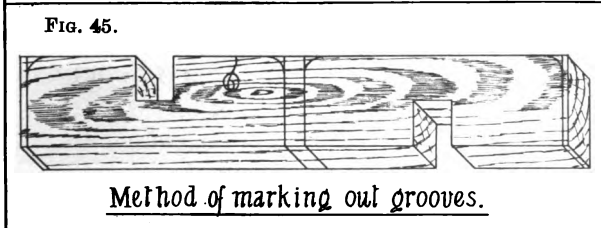
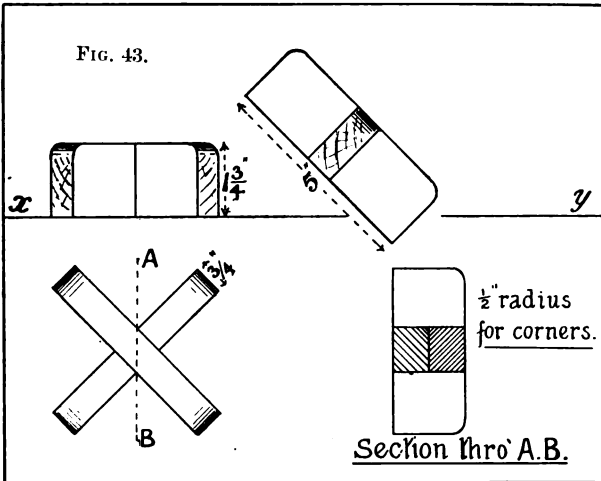

FIG. 42.

**BENCHWORK: Materials.**—Basswood 11in. by 2in. by 1in.

**Method.**—The work in this exercise is straightforward. Mark out carefully (Fig. 45) with one groove from the face edge, and the other from the opposite





one; the reason for this is to bring the face edge of both pieces together when the joint is completed. The corners are pared off with a wide chisel, and should not be found very difficult if thin cuts are taken. Fig. 46 shows how to pare the corners in order to get them round.

### EXERCISE 8.

#### A Calendar Stand. (FIG. 47).

**DRAWING.**—Plan, elevations, and isometric projections (Figs. 48 and 49).

**BENCHWORK: Materials.**—Basswood 11in. by  $4\frac{1}{2}$ in. by  $\frac{3}{4}$ in.

**Method.**—Plane up the length of wood, and mark out in the way illustrated (Fig. 50). It will be seen that a lot of the work may be done before the wood is cut up into pieces. The long saw-cut down the grain should be sawn with the hand-saw before the wood is divided, the shorter ones sawn with tenon saw, and afterwards no difficulty should be encountered, with the exception of the curved top, which is new, but is really only a development of the paring on the corners of the previous exercise; a little of the waste may be sawn off, but it may be pared off quite as quickly if a sharp chisel is used. The nails should be driven in to suit the holes in the calendar. Finally glue up the joints.

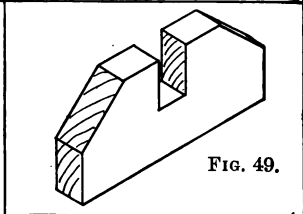
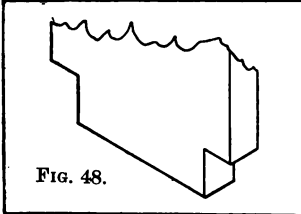
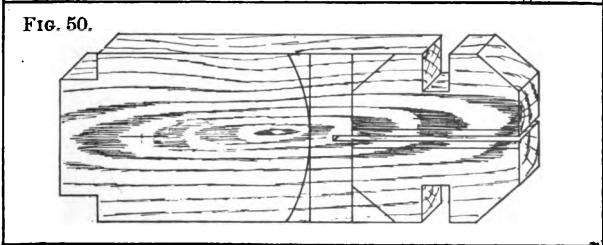
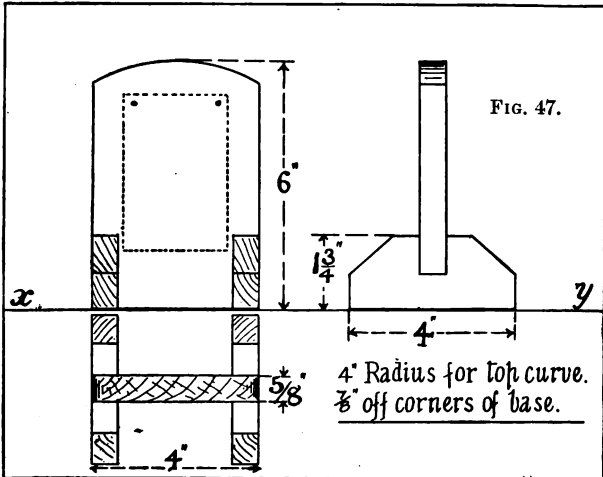

EXERCISE 8.

**EXERCISE 9.****A Lapped Halving Joint.** (Fig. 51.)

**DRAWING.**—Plan, elevation, section, and isometric projection (Fig. 52).

**BENCHWORK :** *Materials.*—Yellow pine and basswood, 11in. by 2in. by 1in.

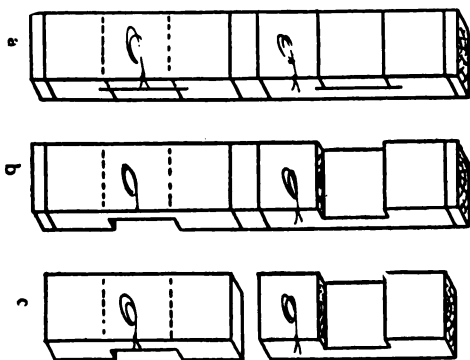
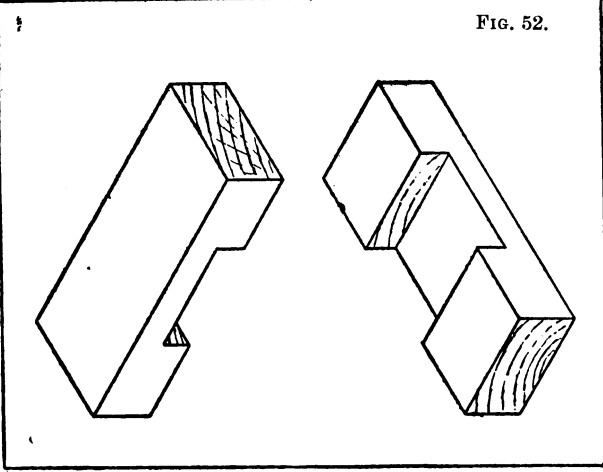
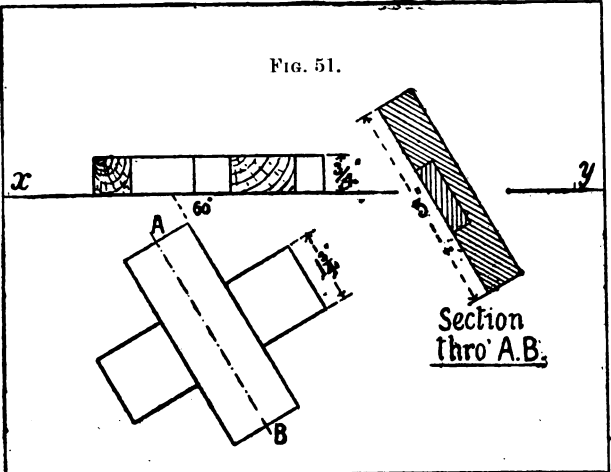

FIG. 53.

*Method.*—This joint, although it looks simple, requires a lot of care in making, especially in marking out and sawing; attention should be given to the illustration of the stages of work (Fig. 53), a little pressure should be required to fit it together, not more than can be exerted by the hand.



EXERCISE 9.

**EXERCISE 10.****A Brush Rack.** (FIG. 54.)

**DRAWING.**—Plan, elevations, and isometric projection (Fig. 55).

**BENCHWORK:** *Materials.*—Satin walnut, 18in. by 2 $\frac{3}{4}$ in. by 1in.

*Method.*—Plane up the whole length, with both edges quite square, then gauge off the width of pieces, and saw between the lines with the hand-saw. Now plane the sawn edges of the strips to gauge lines, and it will then be easy to mark off all the grooves in pairs, and cut them out before the pieces are sawn apart. There is nothing very difficult in this exercise, and is really designed to give more practice in the halving joint.

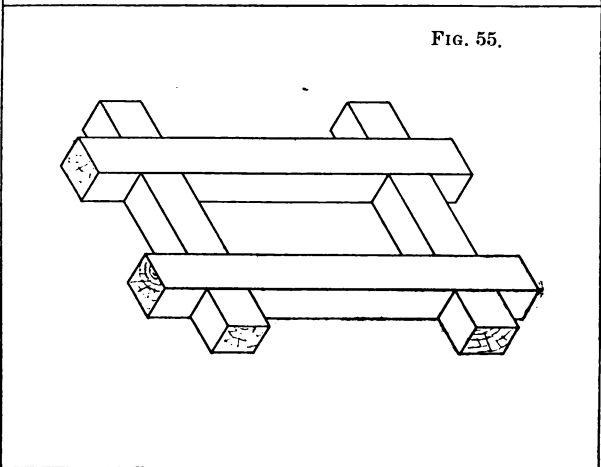
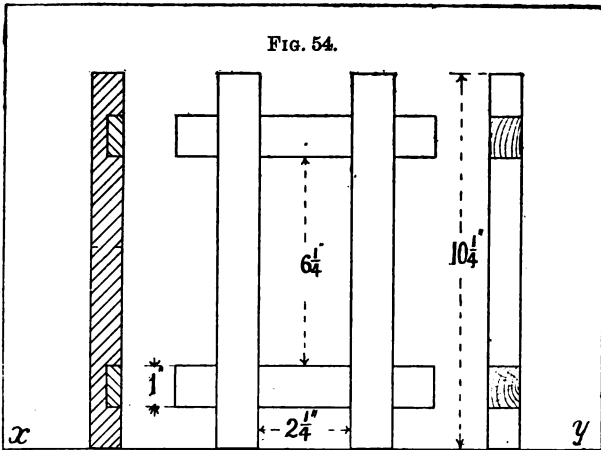

EXERCISE 10.

**EXERCISE 11.****A Dovetail Halving Joint. (FIG. 56.)**

**DRAWING.**—Plan, elevations, section, and isometric projection (Fig. 57).

**BENCHWORK: Materials.**—Pine or basswood, 10in. by  $2\frac{1}{4}$ in. by  $1\frac{1}{4}$ in.

**Method.**—Plane to size, and as this is a joint where it is hardly advisable to mark out completely, one part must be finished first, thus the dovetailed end is the one commenced with. Mark it out accurately, and saw the wide cut across the grain, then place the wood in the vice, so that one of the slanting lines is upright, saw this very carefully, and in order to ensure a good fit a slight amount of bevel should be given, this can be done by starting on the wrong side of the line and finishing on the right side, no more than this should be given, for owing to the shortness of the cut, a very little out of square makes a difference, which would hardly be noticed if the cut were very much longer. When both slanting cuts have been made and the waste carefully cut off, the dovetail should be placed in position, and a line marked each side (Fig. 58). To get a good fit only requires careful sawing and paring in the groove so marked out.

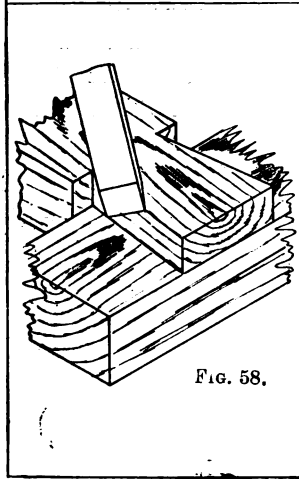
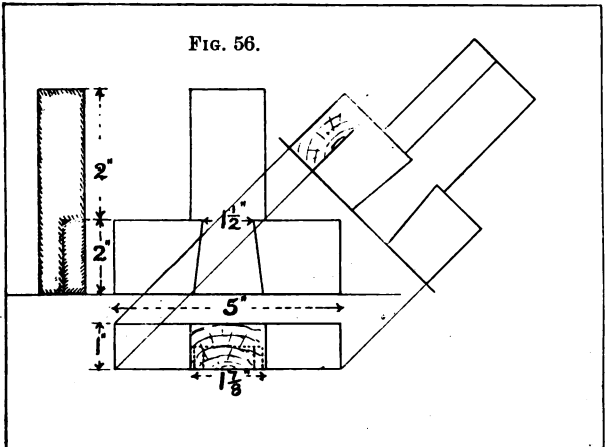

FIG. 58.

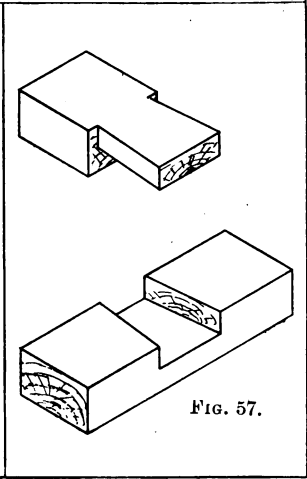

FIG. 57.

EXERCISE 11.



**Examination Test.** (FIG. 59.)

Yellow pine, 12in. by 2in. by 1in. Plane up to size, carefully mark out with a bevel set to the required angle.

**Supplementary Models.** (FIGS. 60 and 61.)

These are given to suggest the kind of exercise likely to prove useful in cases where some finish the course before the others, and where it is found that some particular exercise is too difficult.

The matchbox-holder illustrated at Fig. 60 is a very simple and attractive model, while the rack for keys, Fig. 61, is more difficult, owing to the inlaid pieces.

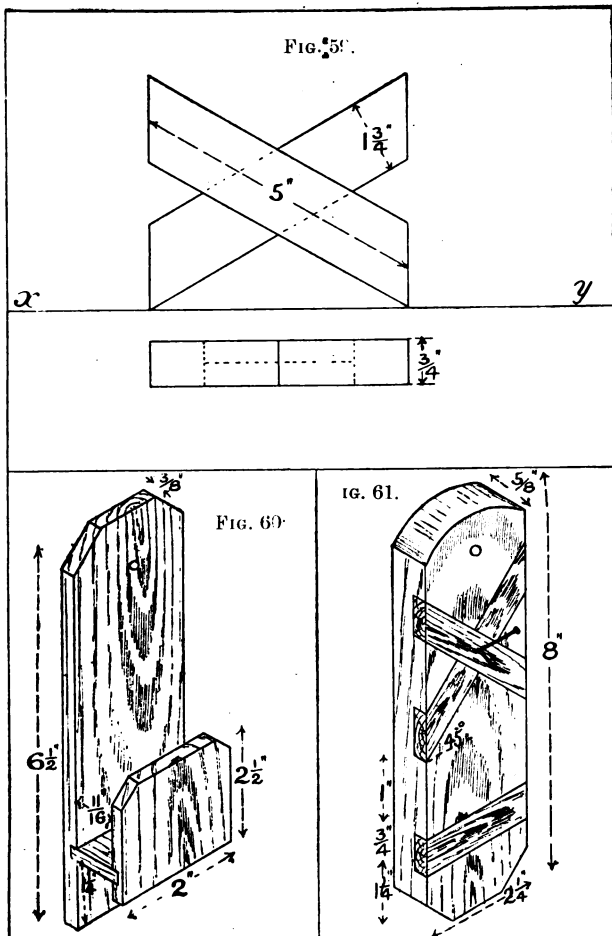

## CHAPTER II.

---

### SECOND YEAR COURSE.

---

#### EXERCISE 12.

#### The Tongue and Groove and Stopped Housing Joints. (FIG. 62.)

**DRAWING:** *Materials.*—Half-inch Imperial drawing board and tee square, ruler, set squares, etc.

With the commencement of the second year's course of work it will be found advisable to use the drawing board and tee square. The practice given by the continued manipulation of the rules and set squares throughout the first year will have proved very valuable in training the fingers.

The plan, elevation, sectional elevation, and isometric projection (Fig. 63), should be drawn.

**BENCHWORK:** *Materials.*—Yellow pine or basswood, 12in. by  $3\frac{1}{2}$ in. by 1in.

*Method.*—Plane to given size, and mark out (Fig. 64), placing the grooved piece in the middle, and the pieces which fit in them, at each end. Gauge grooves to depth, and starting at the end which has been marked for the tongue, treat it like a groove with one side, which should be sawn down, and then pared out with a chisel; now cut out the groove belonging to it, and

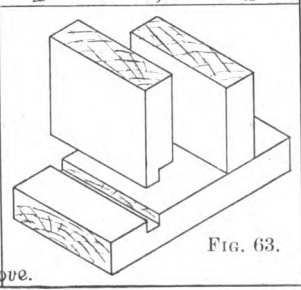
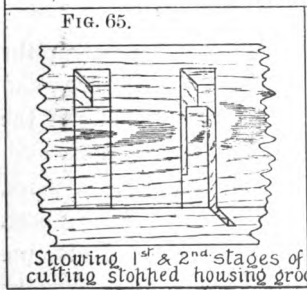
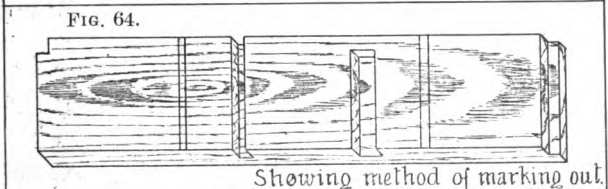
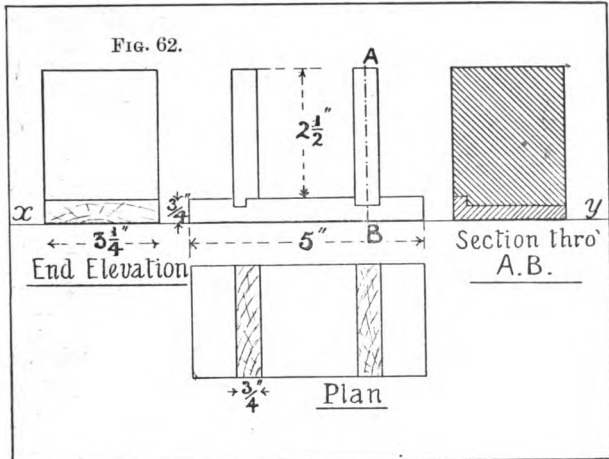

EXERCISE 12,

this is all that is necessary for the tongue and groove joint. The other will be more difficult (Fig. 65); a hole must be mortised the depth of the groove, at the end, and should be done by a  $\frac{3}{4}$ in. chisel driven in across the grain, and across the groove at spaces of about 1-16th in. apart. It will not be difficult to remove the waste, and then if the tenon saw is placed on the end of the line enough play will be given it to start, but the whole saw-cut can only be made by means of short cuts. When this is done on both sides remove the waste, and cutting out the notch from the piece which fits in, the wood now only requires cutting up and each part fitting together.

### EXERCISE 13.

#### A Pencil Box. (FIG. 66.)

**DRAWING.**—The plan, elevations, sections, and isometric projection (Fig. 67).

**BENCHWORK: Materials.**—Satin or black walnut, 11in. by 7in. by  $\frac{1}{2}$ in., and a spokeshave.

**Method.**—In this case it is advisable to plane up the wood first before cutting it into the various sizes, and when this is done saw two strips for the sides of the box, the length allowing one side and end in each piece. These two pieces should be marked in pairs, and all possible grooving cut before sawing apart. Finish the ends with a chisel, fit together and glue up. Now plane up the base to width, and mark out the ends, paring to the line with a wide chisel, then

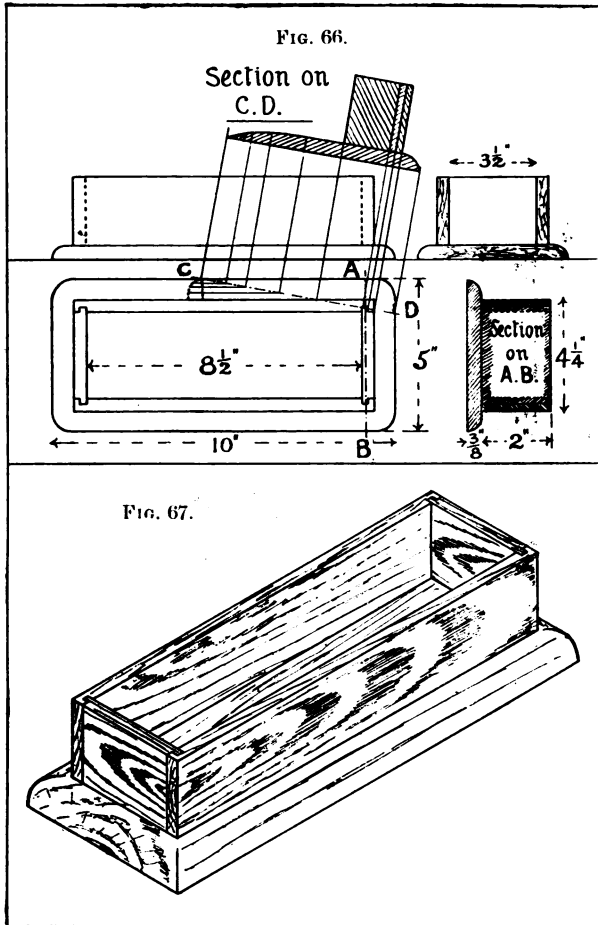

EXERCISE 13.

running a pencil line  $\frac{1}{4}$  in. away on face and edges, plane to the round with a smoothing plane, and the ends with a spokeshave, a tool which should be held tightly in both hands as illustrated (Fig. 68).

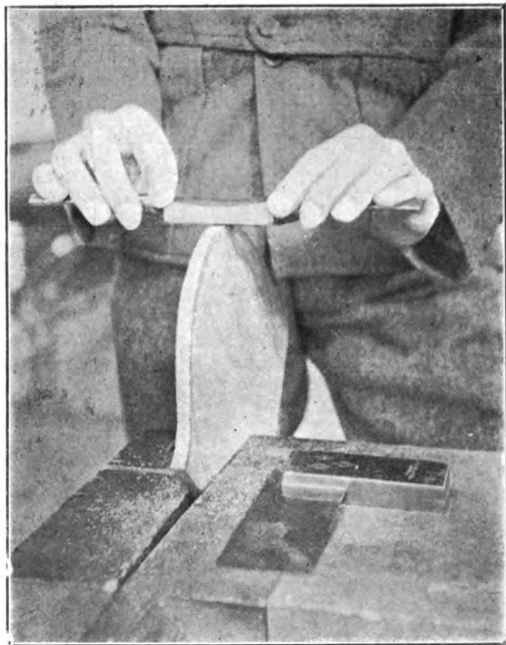

FIG. 68.

To complete, run some glue round the lower edges of the box sides and place in position, putting the box under pressure until dry.



FIG. 74.



**EXERCISE 14.****Mortise and Tenon Joint. (FIG. 69.)**

**DRAWING.**—Plan, elevation, sectional elevation, section, and oblique projection (Fig. 70).

**BENCHWORK: Materials.**—Pine or basswood, 12in. by 1½in. by 1¼in., and mortise chisel.

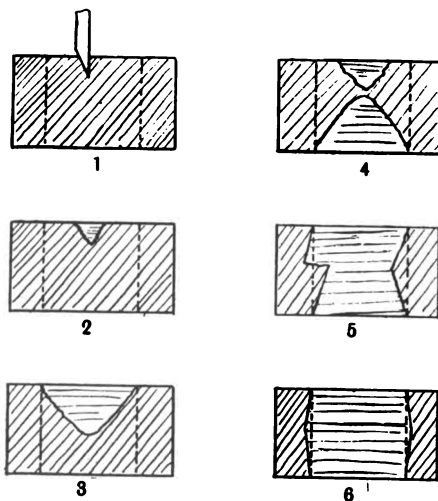

FIG- 75.

**Method.**—This is the most commonly used of woodworkers' joints, and one that, although simple in construction, contains a considerable amount of difficulty. The marking out (Fig. 71) should be done with the mortise gauge, the movable teeth being set to

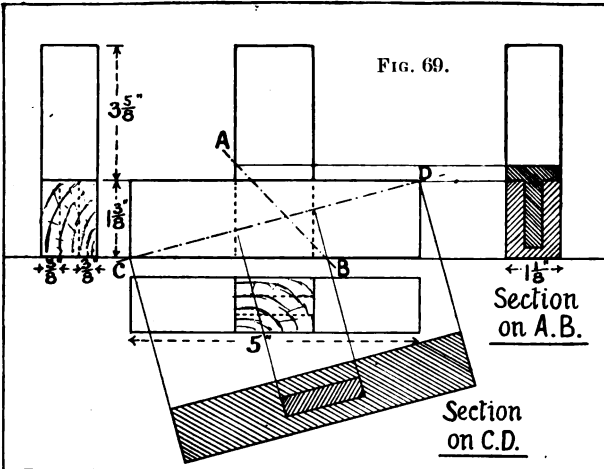
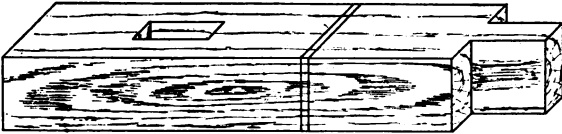
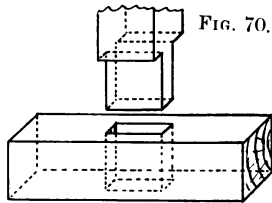
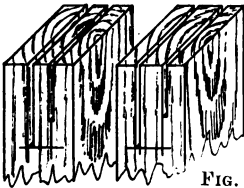

FIG. 71.



WRONG      RIGHT



the width of the mortise chisel (Fig. 73), and then adjusted to the right position. First cut the tenon (Fig. 72) and then the mortise. Hold the chisel as shown in the illustration (Fig. 74), and follow the steps shown in the next diagram (Fig. 75). The first shows the first cut, the next is taken by reversing the chisel, and this will result in a triangular piece being cut away. Continue this, reversing the chisel after

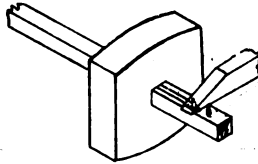

FIG. 73.

each cut until the length of the mortise is reached, the hole being now about halfway down. Now turn the wood over, repeat the operations from the commencement, and this should take the hole through. Now the chisel is placed against the end of the mortise and driven halfway down, the bevel edge being towards the centre, and sufficient undercut given. The last two stages illustrate this slightly exaggerated.

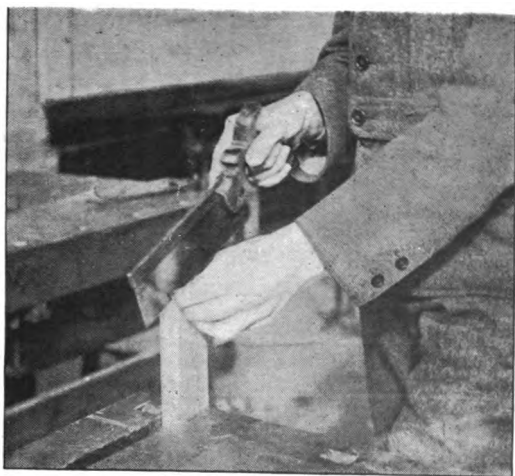

FIG. 81. (EXERCISE 18).

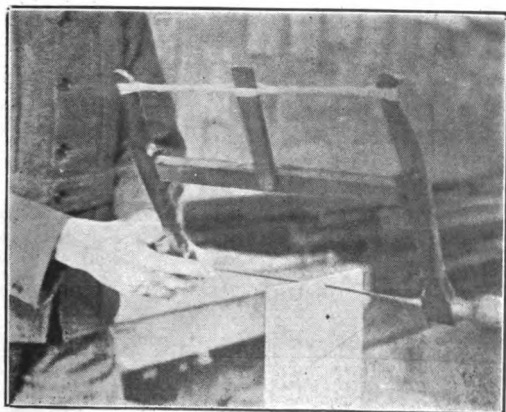

FIG. 92. (EXERCISE 19).

**EXERCISE 15.****A Thermometer Stand. (FIG. 76.)**

**DRAWING.**—Plan, elevations and section, and isometric projection (Fig. 77).

**BENCHWORK: Materials.**—Walnut, either Satin or Black, 10in. by 9in. by 1in., and a 1in. scribing gouge.

**Method.**—Plane up the wood, and, after sawing off the  $1\frac{3}{4}$ in. upright, saw the tenons, shape the end, and make a  $\frac{1}{8}$  chamfer on both sides with plane and spokeshave. Mark out the base (Fig. 78), and cut the mortise—care must be taken that the grain runs the length of the mortise; when this is done, the tenon-saw must be used to cut to triangular shape, and then using the gouge as a chisel (Fig. 79), vertically pare to within a little way of the lines, and finish smooth and square with the spokeshave. The corners are left till last, and are pared with a wide, firmer chisel; then everything is ready for finally glueing and fixing together.

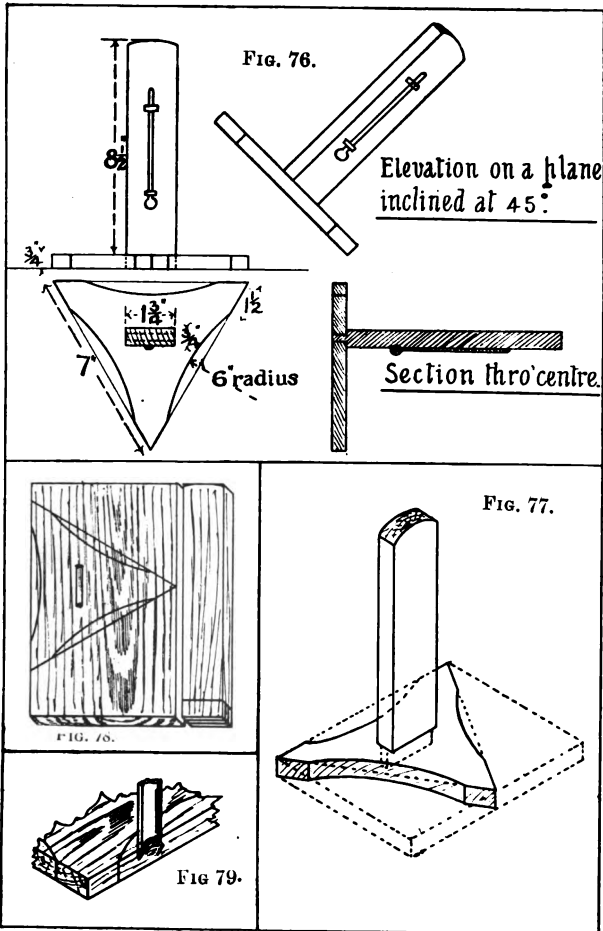

EXERCISE 15.

**EXERCISE 16.****A Bridle Joint. (FIG. 80.)**

**DRAWING.**—Plan, elevation, section, and isometric projection (Fig. 81).

**BENCHWORK:** *Materials.*—Yellow pine or basswood, 10in. by  $1\frac{1}{2}$ in. by  $1\frac{1}{4}$ in., and a mortise gauge.

*Method.*—Plane up to size and mark out (Fig. 82), using the mortise gauge. Set this carefully, the distance between the teeth exactly the same as the middle space in the joint, one-third of the thickness, and so adjust the stem, that the two teeth come in the

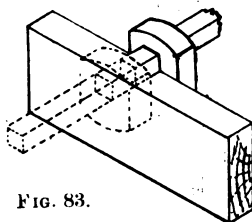
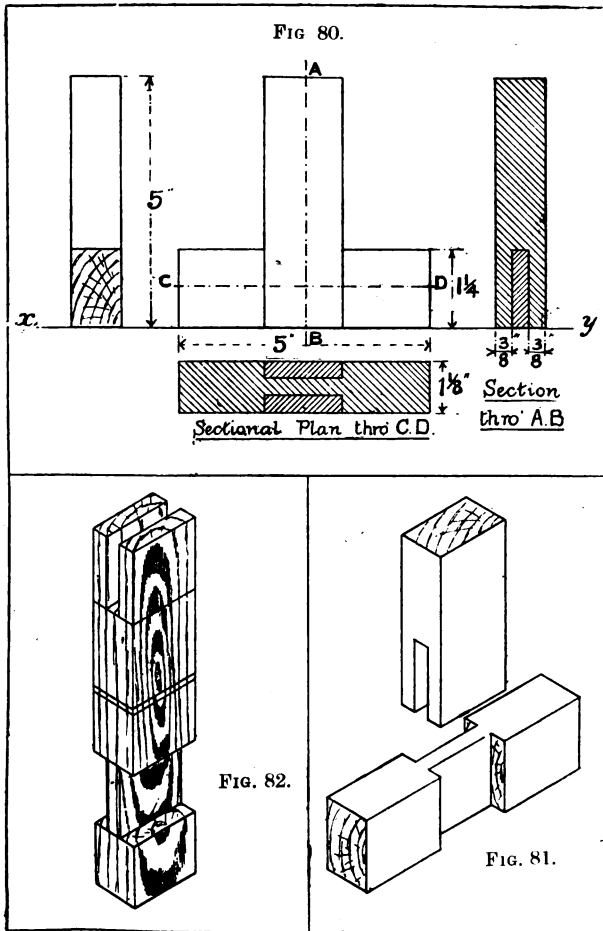

FIG. 83.

middle of the wood; to get this exact, see that the marks made by the spurs coincide (Fig. 83). When the marking is done use the tenon saw to saw down the grain. Start at the far corner and gradually bring the saw along the line, remembering to keep the waste side, and saw with straight and long cuts down to the bottom of the tenon (Fig. 84—p. 53). Great care must be taken, for the slightest amount out of truth will prevent the joint fitting properly. Pare the core out as shown in Fig. 85. The grooves on the side are simple, and require no explanation.



EXERCISE 16.



**EXERCISE 17.****A Try Square. (Fig. 86.)**

**DRAWING.**—Plan, elevations, and isometric projection (Fig. 87).



FIG. 85.

**BENCHWORK:** *Material.*—Black walnut, 12in. by 2in. by 1in.

*Method.*—First plane all the wood to size,  $1\frac{1}{4}$ in. wide and  $\frac{3}{4}$ in. thick, mark out on one end, and cut the open mortise. From the other end must be sawn the strip

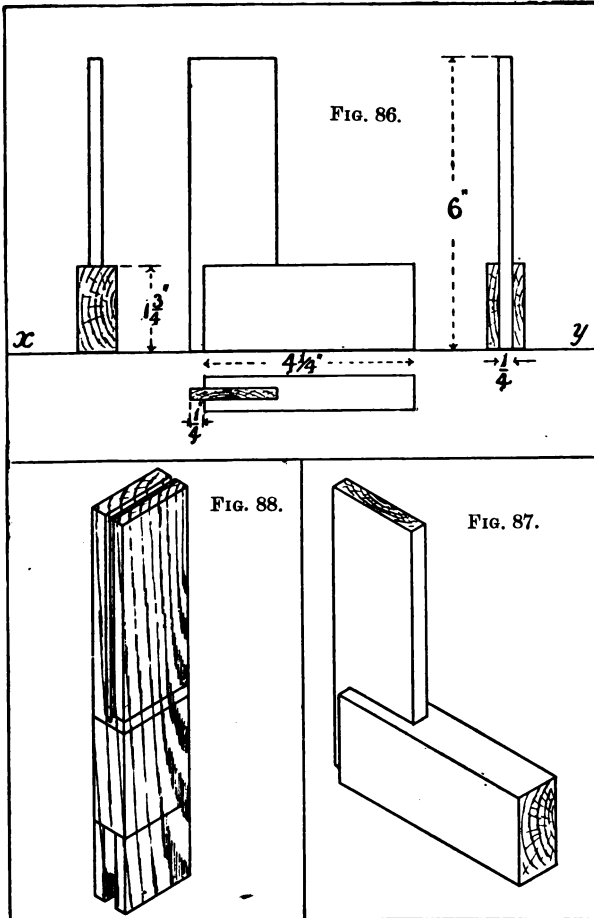

EXERCISE 17.

for blade (Fig. 88), and a gauge set to the thickness,  $\frac{1}{4}$  in. should be run from the face side, the hand-saw being used to saw it off. Care should be exercised not to go too near the line, for if the cut is uneven it will render the planing more difficult. If the joint has been accurately cut the blade will fit quite square, and may be glued up.

### EXERCISE 18.

#### A Cogging Joint. (FIG. 89.)

**DRAWING.**—Plan, elevations, sections, and isometric projection (Fig. 90).

**BENCHWORK: Materials.**—Pine or basswood, 10 in. by  $2\frac{1}{4}$  in. by  $1\frac{1}{4}$  in.

**Method.**—In marking out this joint (Fig. 91), it will be found advisable to use the mortise gauge when making the lines along the face. The difficulty is, of course, in cutting out the two notches. The tenon saw must be used to saw down to the diagonal, but after that the chisel only can be relied on; treat the work as a groove, and carefully run the chisel edge along the gauge line to a depth of  $\frac{1}{4}$  in., then pare that amount out as in a stopped groove, keeping a firm hold of the chisel to avoid cutting past the line; if before each cut the chisel is used to cut across the fibres there will be no further difficulty in making the square notch.

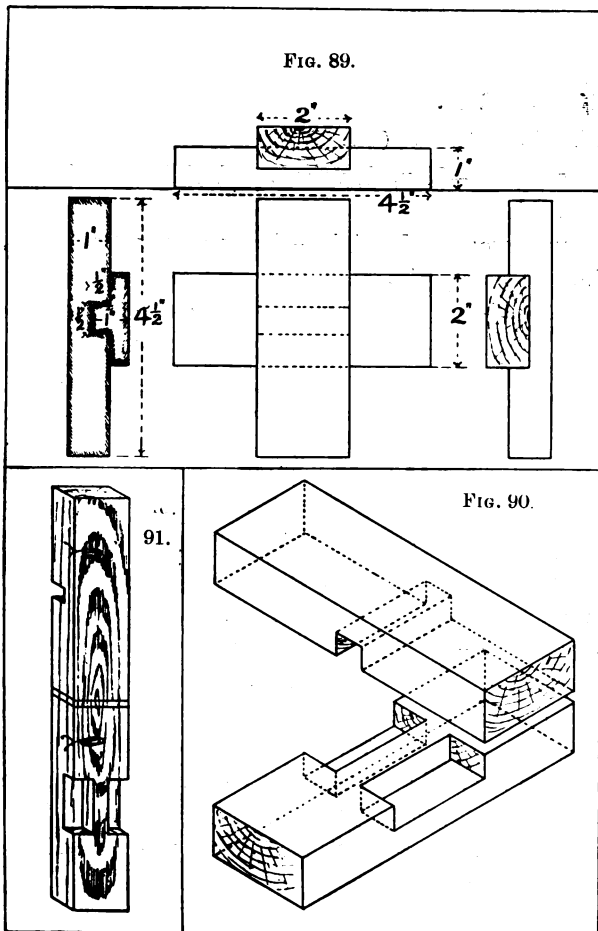

EXERCISE 18.

**EXERCISE 19.****A Watch Stand. (Fig. 93.)**

**DRAWING.**—Plan, elevations, and oblique projection (Fig. 94).

**BENCHWORK: *Materials.***—Basswood or satin walnut, 9in. by  $6\frac{1}{4}$ in. by  $\frac{3}{4}$ in.

***Method.***—As all the pieces can be cut from the one length of board it will be better to plane it up first, and then cut up into the various pieces (Fig. 95). Start with the joints, make them as in the previous exercise, and then shape out the top piece with bow-saw and spokeshave. If the alternate model (Fig. 94) is taken then the round hole must be cut out with bit and gouge before the shaping is commenced. This would make a nice stand for a Bee clock. The small curves are made first with a  $\frac{3}{4}$ in. bit, then the bow-saw (Fig. 92—p. 53) used to saw nearly to the curve, and care should be taken that the saw-cut is at right angles to the face; the spokeshave must be used to clean up the edges, and when this is finished, pare the straight parts on each side with a sharp chisel, this will ensure a clean edge. Now the chamfering should be done, and after finally cleaning up, all the pieces should be glued together.

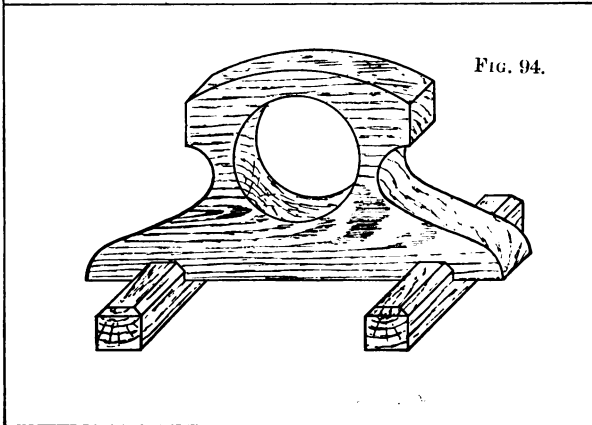
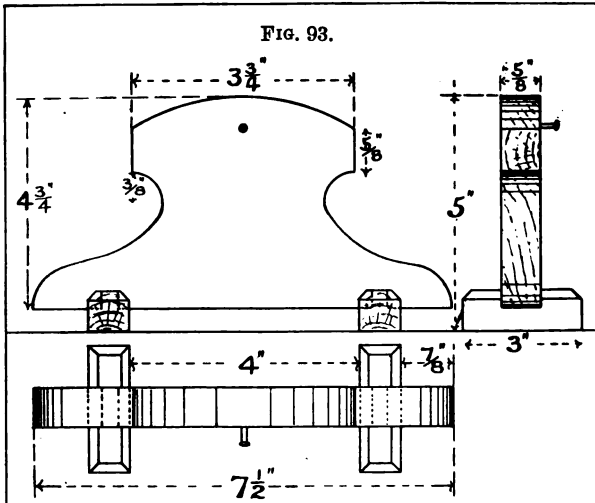

EXERCISE 19.

**EXERCISE 20.****A Double Mortise and Tenon Joint. (FIG. 96.)**

**DRAWING.**—Sectional plan, elevations, section, and isometric projection (Fig. 97).

**BENCHWORK: *Materials.***—Pine or basswood, 10in. by 2in. by 2in.

***Method.***—Practically the same method used in making the mortise and tenon joint applies in this case, with, of course, an increased amount of care in marking out. One set of gauge lines for both mortise and tenon must be done before the gauge is altered. Other than this difference the mortising and sawing is the same. This joint will prove a very good test of sawing, for unless the work has been quite accurate the joint will not fit.

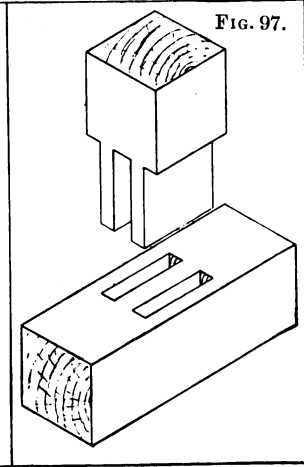
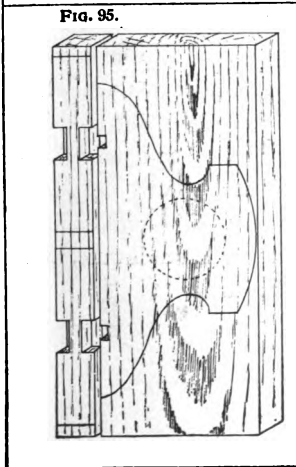
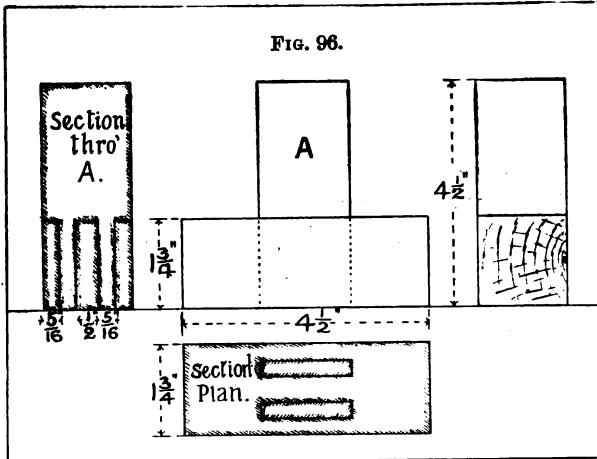



**EXERCISE 21.****An Inkstand. (FIG. 98.)**

**DRAWING.**—Plan, elevation, and sections.

**BENCHWORK:** *Material.* — Walnut, 20in. by 7in. by  $\frac{3}{4}$ in.

*Method.*—Plane up the length of wood, and mark out as much as possible (Fig. 99). No dimensions are given of the mortise for the inkwell, this should be made to actual measurement. The ellipse should be left till last, so as to give a sufficient length of wood in the vice while shaping the upper part. It will be advisable to cut the mortise before the ellipse is commenced, the rectangular piece of wood being better to hold. Fig. 100 shows the double mortise and tenon joint used in fixing the large upright; it will entail very careful work. Fig. 101 shows how the smaller piece is housed in; this should be done with small cuts, taking great care not to go outside the line.

FIG. 98

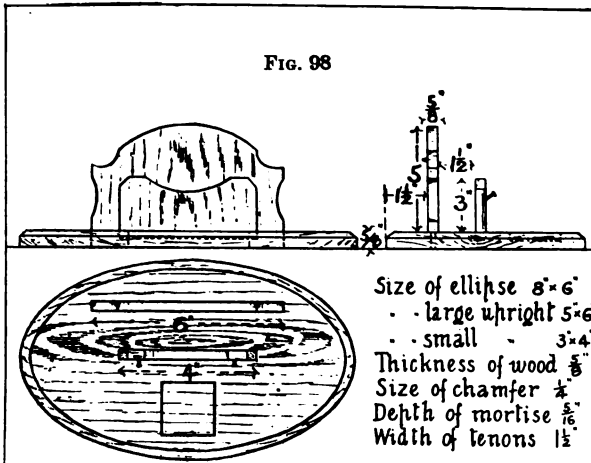

FIG.  
99

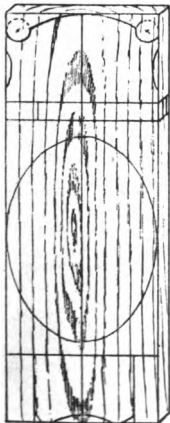
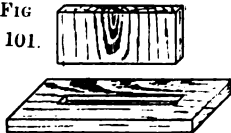

FIG. 100.



FIG  
101.



EXERCISE 21.

**EXERCISE 22.****A Haunched Mortise and Tenon Joint.** (FIG. 102.)

**DRAWING.**—Plan, sectional, and side elevations, and isometric projection (Fig. 103).

**BENCHWORK: *Materials.***—Pine or basswood, 10in. by 2 in. by  $1\frac{1}{4}$ in.

***Method.***—This style of mortise and tenon is used when the mortise is near the end of the wood, and where the open joint would not be suitable, and it requires considerable care in making. In marking out (Fig. 104), leave as much waste as possible at the end where the mortise comes, to avoid risk of splitting out the fibres, and mortise through for the narrow part of the tenon, leaving the small gap until last when finally fitting together. In sawing the tenon, saw down all three lines with the grain before cutting the shoulders. If the joint is made in this way, with the practice gained in making the previous ones, a first-rate fit should be the result.

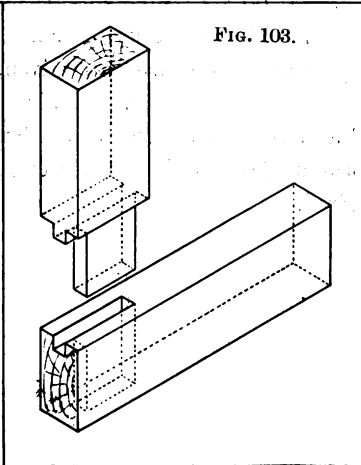
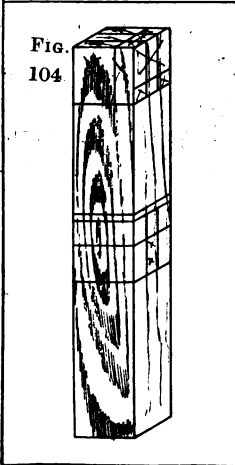
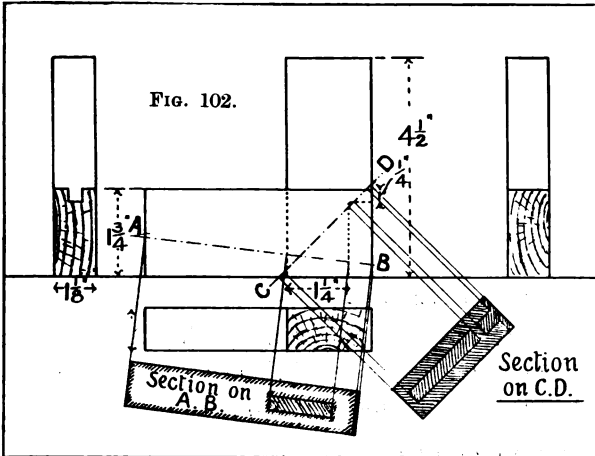

**Examination Test.** (FIG. 105.)

Yellow pine, 12in. by 2in. by 1in. Plane up to size, carefully mark out while in one piece, and cut out the grooves before sawing apart.

**Supplementary Exercises.**

Fig. 106 gives a useful stand for use in chemical experiments; no sizes are given, but the proportions should be adhered to. Fig. 107 gives an illustration of a more difficult form of the bridle joint, and should form useful practice at the end of this course if required.

FIG. 105.

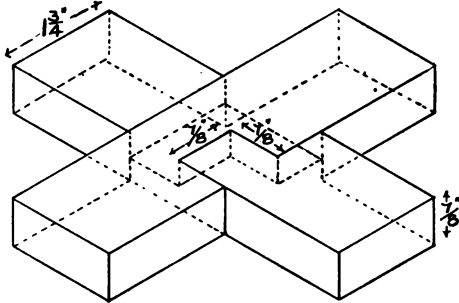

FIG. 106

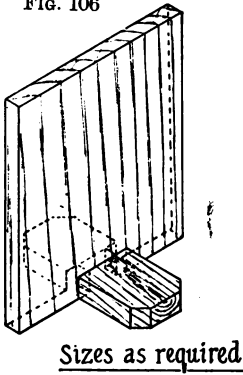
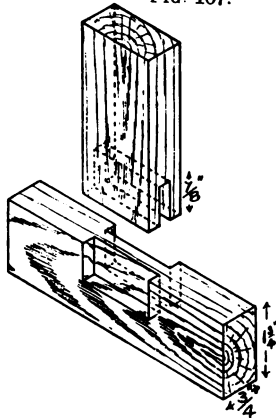

FIG. 107.



## CHAPTER III.

---

### THIRD YEAR COURSE.

---

#### EXERCISE 23.

##### **Dovetail Joint.** (FIG. 108.)

**DRAWING.**—Plan and elevation, section and isometric projection (Fig. 109).

**BENCHWORK:** *Materials.*—Pine or basswood, 11in. by  $4\frac{1}{4}$ in. by  $1\frac{1}{2}$ in. and a bevel.

*Method.*—Plane up the wood, and saw carefully into two equal pieces,  $5\frac{1}{2}$ in. long. Use these sawn ends for the joint, and take one piece and mark out the pins (A, Fig. 109),  $\frac{1}{8}$ in. from each end mark a line across which will be the centre of the end pins, then divide the intervening portion into three equal parts, the lines dividing these spaces will be the centre of the other pins. The width of the wide part of the pin is usually about half the thickness of the wood, and the narrow part about half that size. The width of the broad part in this case would be  $\frac{1}{2}$ in. and the narrow part  $\frac{1}{4}$ in., so mark off each side of the centre of pin  $\frac{1}{4}$ in., and for narrow part  $\frac{1}{8}$ in., and of course only on one side of the end pins; square all lines down to gauge lines, and mark lines across the end with

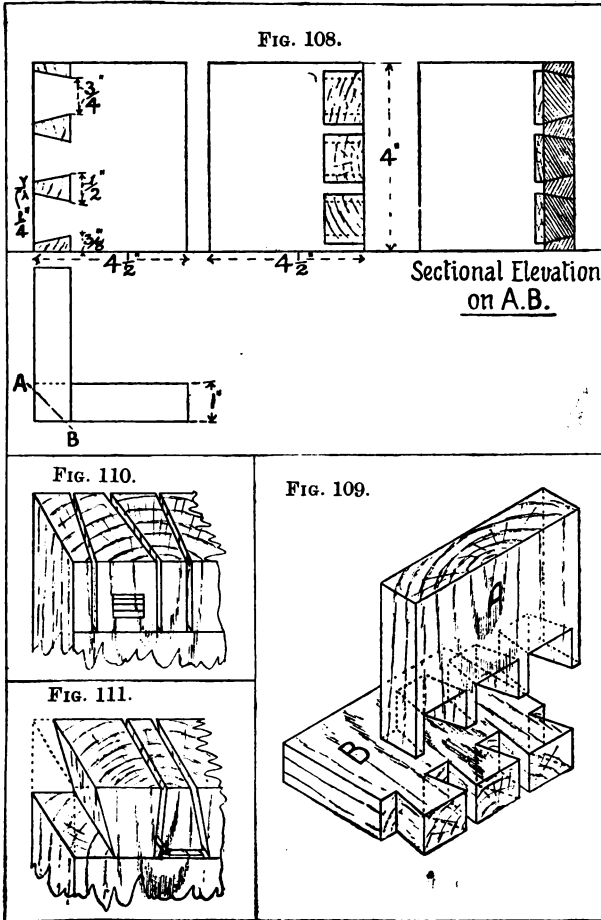



a bevel. Saw down the lines with the tenon-saw, and then mortise the waste out, using a chisel as wide as the narrow part (Fig. 110); when the pins are finished place the piece containing them on the side of the other piece, and mark out their shape (B, Fig. 109). Square these lines across the end, and saw down to depth, taking care to keep on waste side of the line; to take the waste out, put the bow-saw in the cut, and saw a little away from the line (Fig. 111), afterwards paring out with the chisel. Fit the joint together, and plane off the surplus ends.

#### EXERCISE 24.

##### A Vernier. (FIG. 112.)

**DRAWING.**—Plan, elevation, and isometric projection (Fig. 113).

**BENCHWORK: Materials.**—Black walnut for back, 15in. by  $2\frac{1}{2}$ in. by  $\frac{3}{8}$ in.; mahogany for fronts, 18in. by 1in. by  $\frac{3}{8}$ in.; sycamore for slide, 6in. by 1in. by  $\frac{3}{8}$ in.

**Method.**—Plane up the wood for back to  $2\frac{1}{4}$ in. wide, and  $\frac{1}{4}$ in. thick, finishing with trying plane to get the surface perfectly true, then plane up the mahogany to  $\frac{1}{4}$ in. thick, with both edges true, and after gauging 1in. from each edge, run pencil lines  $\frac{1}{8}$ in. away on face side and from both edges, and plane down to the line, this will form the inside bevel; when this is finished saw the strips apart and plane to lines. Now before the

FIG. 112.

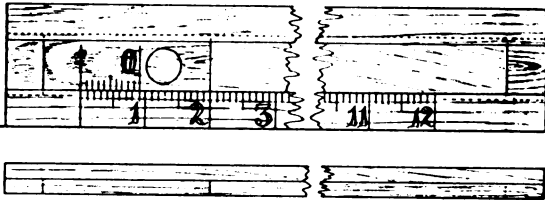
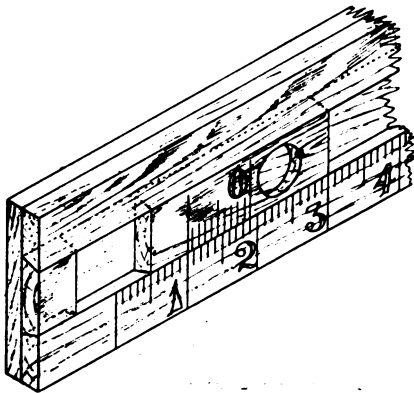

FIG. 113.



slide can be fitted these strips must be glued and screwed in their place, and the waste ends sawn off and kept until after the slide is fitted, and then fixed in their places. The slide should run easily along the groove, and the round hole bored right through. The marking will take a lot of care, and if the vernier is to be of any use, must be accurate.

### EXERCISE 25.

**Model of Geometrical Planes.** (FIG. 114).

**DRAWING.**—Plan, elevations, and isometric projection (Fig. 115).

**BENCHWORK:** *Materials.*—Basswood, 2ft. 6in. by 8in. by 1in.

*Method.*—The exercise brings into use the haunched double mortise and tenon joint, and requires very careful work to get each plane square. The joints are marked out and cut in a similar way to the double mortise and tenon in Exercise 21, Fig. 100, but with the addition of the haunch (Fig. 116). Two short pieces of hard wood will be required to form the hinges, and should be screwed on when both planes are end to end; this will allow enough “play” for the vertical plane to stand on the horizontal one, and also will permit of them being folded together.

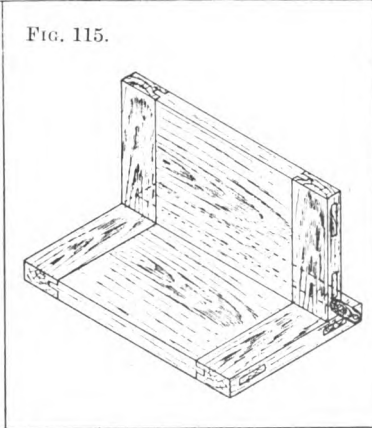
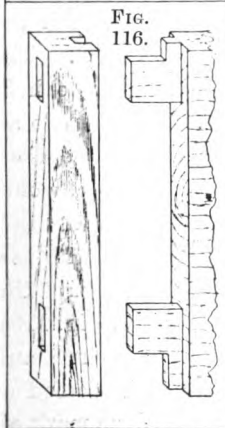
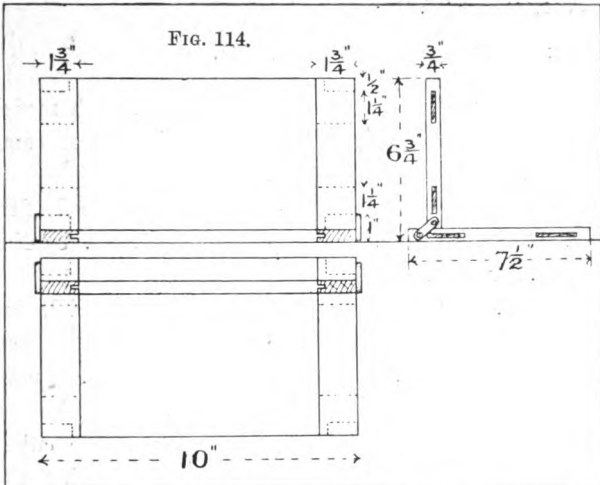

EXERCISE 25.

**EXERCISE 26.****Geometrical Models.** (FIG. 117).

**DRAWING.**—The plan and elevation of each model should be drawn, and the oblique projection of completed set mounted (Fig. 118).

**BENCHWORK: Materials.**—Pine or basswood, 2ft. 6in. by 7in. by  $1\frac{1}{4}$ in. for models, and 2ft. 6in. by 4in. by  $\frac{3}{4}$ in. for base.

**Method.**—First plane up the length of material, saw it down, then glue the face sides together in the way shown (1, Fig. 119), this will form a 3in. square prism. When the glue is set, clean up, and after paring one end smooth and square, cut off the cube; next draw the diagonal on the end, and with the tenon-saw cut away most of the waste, and finish the pyramid with smoothing plane (1, Fig. 119). The sawn pieces should be used to form a box to hold pyramid in while finishing the base. Next set out an octagon on the end, and run the lines along the sides, and plane down to them, and cut off the octagonal prism 4in. long, and clean up the end with a chisel. Find the centre of the remaining piece, and with saw and smoothing plane shape the octagonal pyramid 4in. long; saw it off and clean up the base (2, Fig. 119). Now describe on both ends of remainder a circle and carefully plane down, placing a piece of lin. wood at the end of vice to hold it. When this is done mark off the length of cone, and in the same way as in making

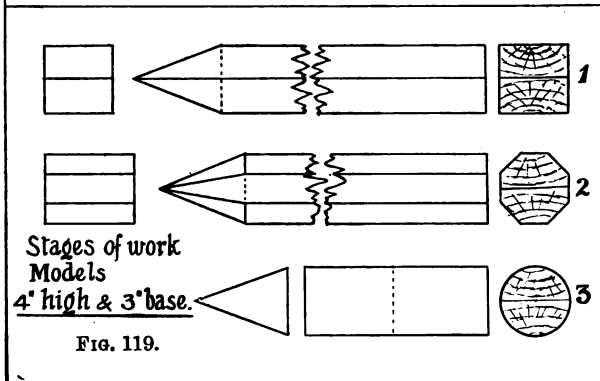
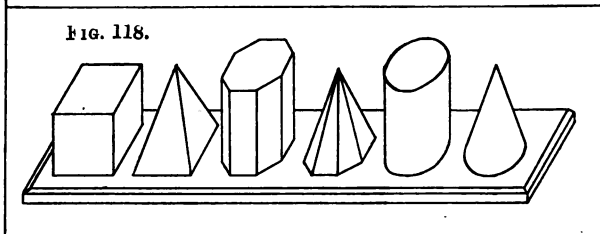
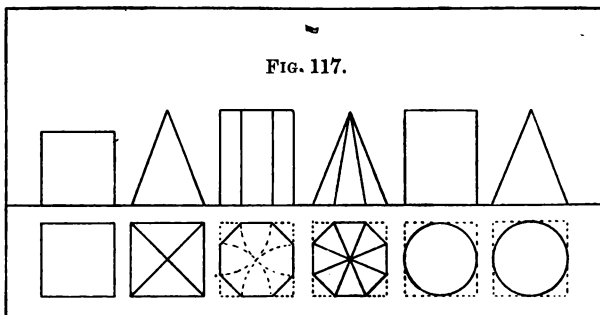

EXERCISE 26.

octagonal pyramid cut away the wood to a point, finally cutting it off, as well as the cylinder (3, Fig. 119). The base must be planed up, chamfered, and recesses cut to a depth of  $\frac{1}{8}$  in. to take each model.

### EXERCISE 27.

**Lap Dovetail.** (FIG. 120).

**DRAWING.**—Plan, elevation, and isometric projection (Fig. 121).

**BENCHWORK:** *Materials.*—Pine or basswood, 1 in. by  $4\frac{1}{4}$  in. by  $1\frac{1}{2}$  in.

*Method.*—Mark out the joint in the opposite manner to the common dovetail (Fig. 109), but of course leaving the amount to lap over. The sockets require carefully cutting out, and saw with tenon and bow saws. The pins are marked out and cut, taking out the waste in the same way as the notches were cut in the cogging joint.

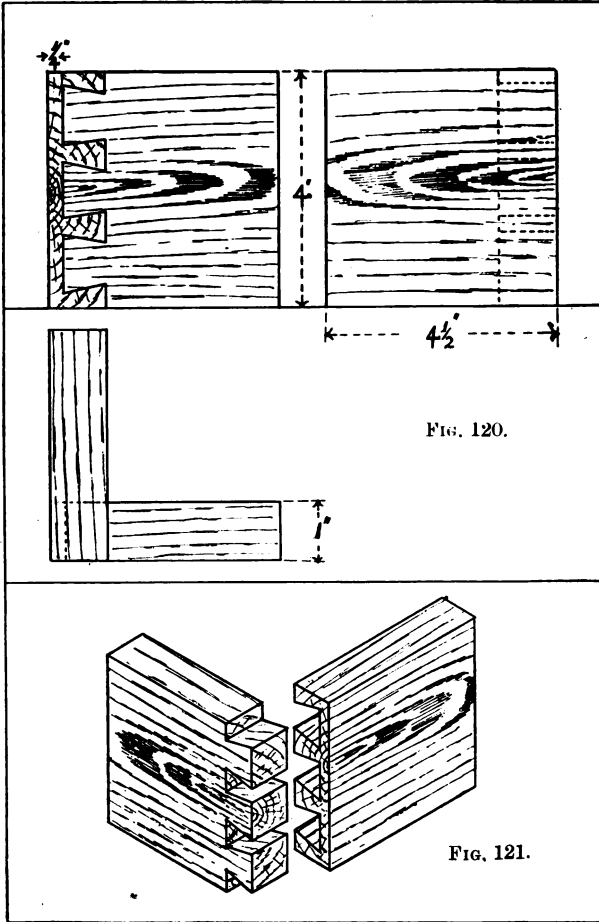

FIG. 120.

FIG. 121.

EXERCISE 27.



**EXERCISE 28.****A Test Tube Stand.** (Fig. 122).

**DRAWING.**—Plan, elevations, section, and isometric projection (Fig. 123).

**BENCHWORK: Materials.**—A hard wood, preferably 1ft. 8in. by 8in. by  $\frac{3}{4}$ in. Teak, and a firmer gouge.

**Method.**—After planing up the wood, divide it into the required pieces, mark out and cut the lap dovetails, and then the mortise and tenon joints at the top, next bore the holes for test tubes ( $\frac{3}{4}$ in.), and with a firmer gouge hollow out a place for the tubes to stand in, if a firmer gouge of the same curve as the required hole is held upright, turned round, and gradually slanted outwards, a round shallow hole will result. The sides may now be shaped, first sawing out with bow-saw, and finished with spokeshave before corners are cut off. The pegs should now be prepared, enough wood will be left from the piece to make them, and the best way would be to saw a  $\frac{5}{8}$ in. strip from one edge and cut it up into lengths after the whole strip is planed up to  $\frac{1}{2}$ in. square. Holes must now be mortised to receive them, and must be cut out with a chisel a little under the size of pegs in order to ensure a good fit.

FIG. 122.

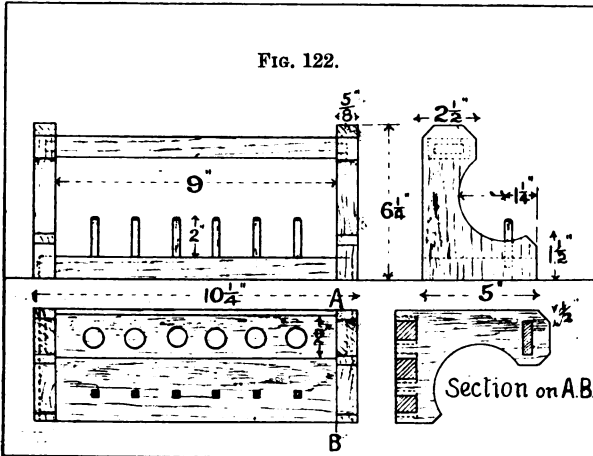
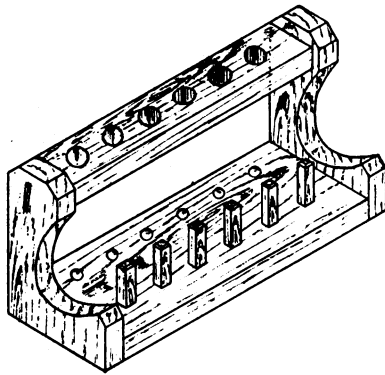

FIG. 123.



EXERCISE 28.

**EXERCISE 29.****A Tusk Tenon.** (FIG. 124).

**DRAWING.**—Plan, elevation, and isometric projection (Fig. 125).

**BENCHWORK :** *Materials.*—Pine or basswood, 10in. by 2 $\frac{3}{4}$ in. by 1 $\frac{1}{4}$ in.

*Method.*—Plane up material, and run centre line on both sides; mark wood in half, and on one end set out the tenon; set the gauge to proper sizes, and mark off position on both tenon and mortise; if these sizes are both marked together there will be less chance of going wrong. Saw out tenon first, cut it off, then cut mortise, and fit together. Afterwards make the peg, and cut a hole in the tenon, allowing a little space inwards to draw the joint tight.

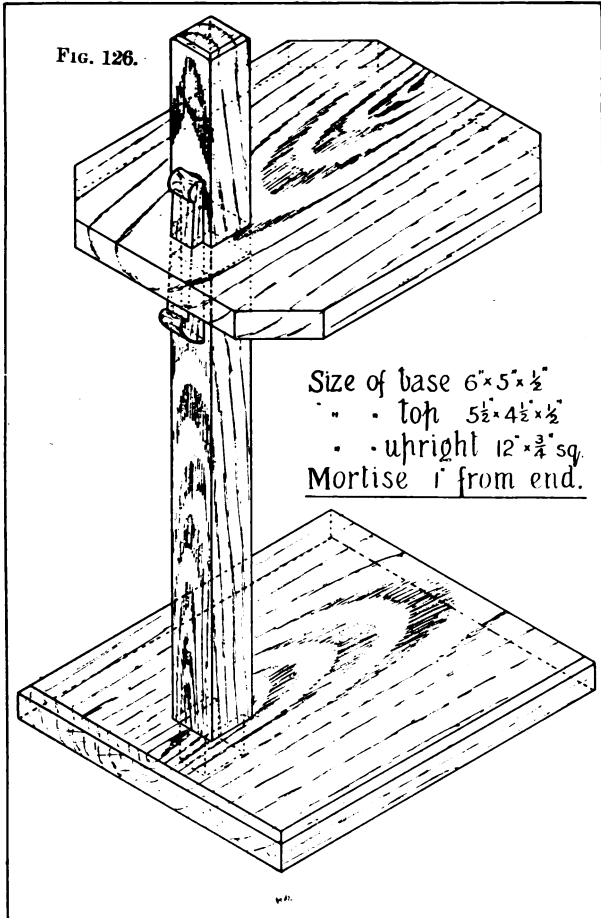

EXERCISE 30.

**EXERCISE 31.****A Dovetail Joint. (FIG. 127).**

**DRAWING.**—Plan, elevations, section, and isometric projection (Fig. 128).

**BENCHWORK :** *Materials.*—Yellow pine, 1lin. by 2 $\frac{1}{4}$ in. by 1in.

*Method.*—The success of this exercise depends on accurate marking out and sawing, for the slightest amount out of truth will show and spoil the look of the finished work. All sawing and chisel work should be finished before pieces are cut apart.

FIG. 129.

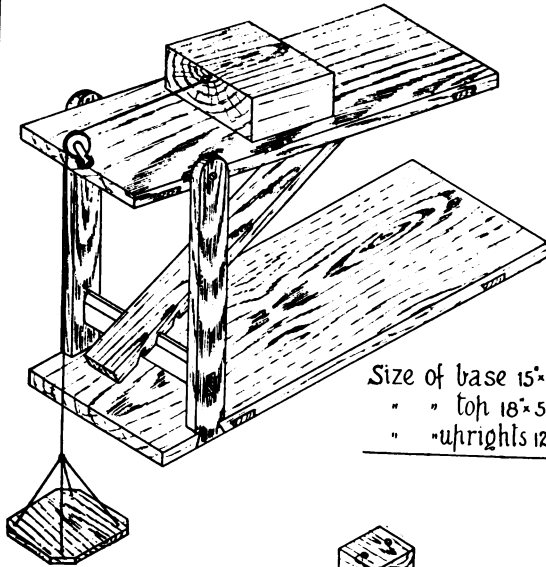

FIG. 130.

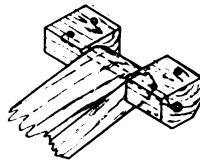

FIG. 131.

EXERCISE 32.

**EXERCISE 33.****A Marking Gauge.** (FIG. 132).

**DRAWING.**—Plan, elevation, and isometric projection (Fig. 133).

**BENCHWORK :** *Materials.*—Beech, 5in. by 2½in. by ¾in. for stock and wedge; 1lin. by ¾in. by ¾in. for stem.

*Method.*—Mark out the stock, and cut the mortise, afterwards boring holes for small curves, and finishing with bow-saw and spokeshave. When stock is completed, fit the stem in carefully, and finally make and fit the wedge, bore the hole for spur with a fine bradawl, and insert the nail, sharpening afterwards with a file.

FIG. 132.

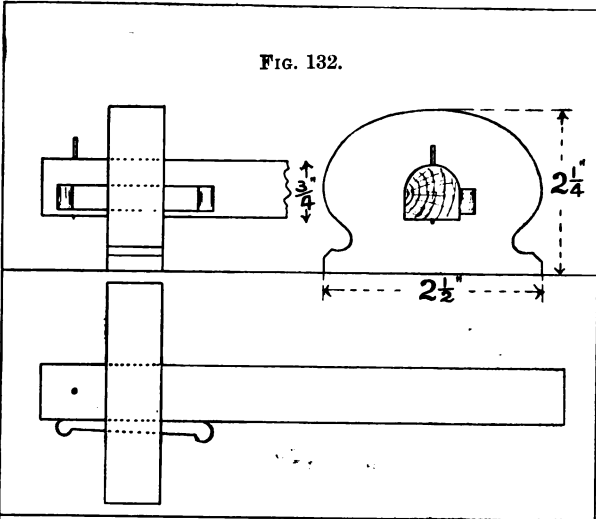
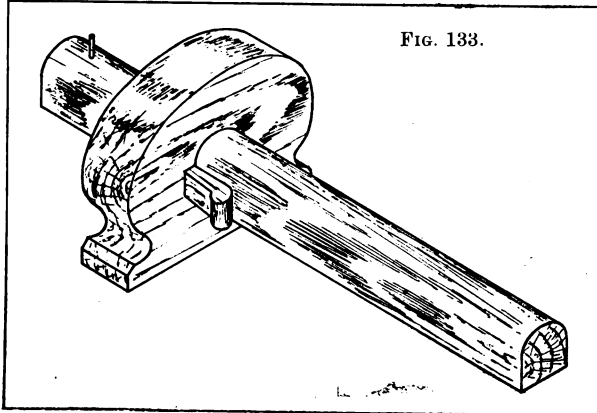

FIG. 133.



EXERCISE 33.



**Examination Test.** (FIG. 134).

Yellow pine, 12in. by 1 $\frac{1}{2}$ in. by 1 $\frac{1}{2}$ in. Plane to size, 1 $\frac{1}{2}$ in. square, and mark out with mortise gauge, and carefully cut the grooves and pins.

FIG. 134.

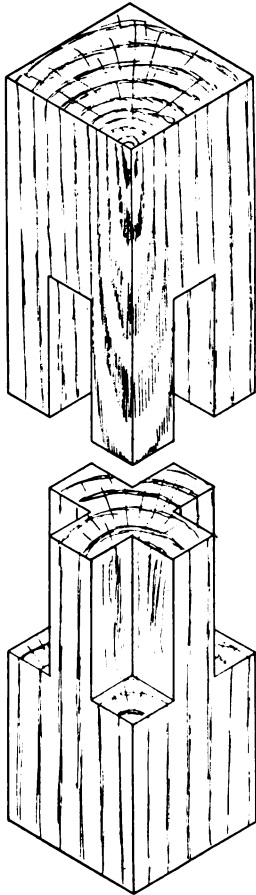

EXAMINATION TEST.

**Supplementary Models.**

Figs. 135 (a box) and 136 (a finger plate), give two examples of suitable inlaid work. In both cases the inlay is in thin wood, and goes really through it, but if a piece of drawing paper is glued underneath, and a piece of thicker wood glued to that, the difficulty of cutting the thin piece will be overcome, and the use of a router avoided. The pieces should all be planed, fitted and glued up before fitting in. It is not satisfactory to fit each piece in separately.

Fig. 135

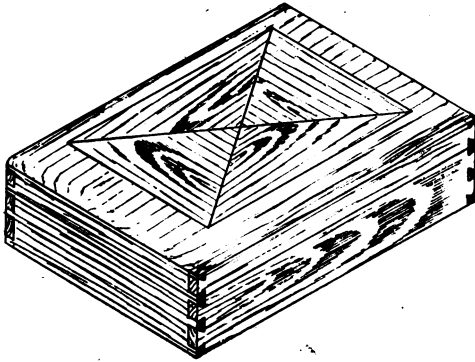
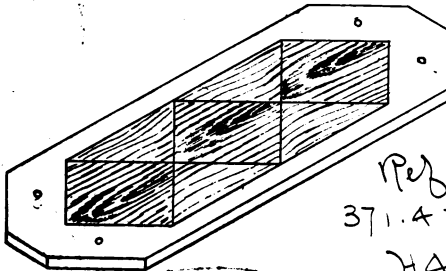

Fig 136



36722

## CHAPTER IV.

---

### FITTINGS AND FURNITURE.

---

One of the greatest helps to successful work are good fittings. There should be a place for everything, and yet in how many places are the tools and work piled up in odd cupboards and corners, in disorder.

A proper and orderly arrangement of apparatus is imperative if perfect discipline is required, and the best way to arrange the room is often a difficult problem to solve. Not only is an orderly room a pleasure to work in, but it has a great educational value in appealing to the boys' sense of order.

Some rooms lend themselves to a little artistic effect, and there is no reason why that effect should not be given. Why should the manual training room so often look like a whitewashed barn? A little thought and work would soon impart to the plainest-looking room a much more interesting appearance.

*Arrangements of Benches.*—As much space as possible should be left between benches. Figs. 137—140 show various arrangements. The benches themselves should be as solid as possible, and whenever possible fixed to

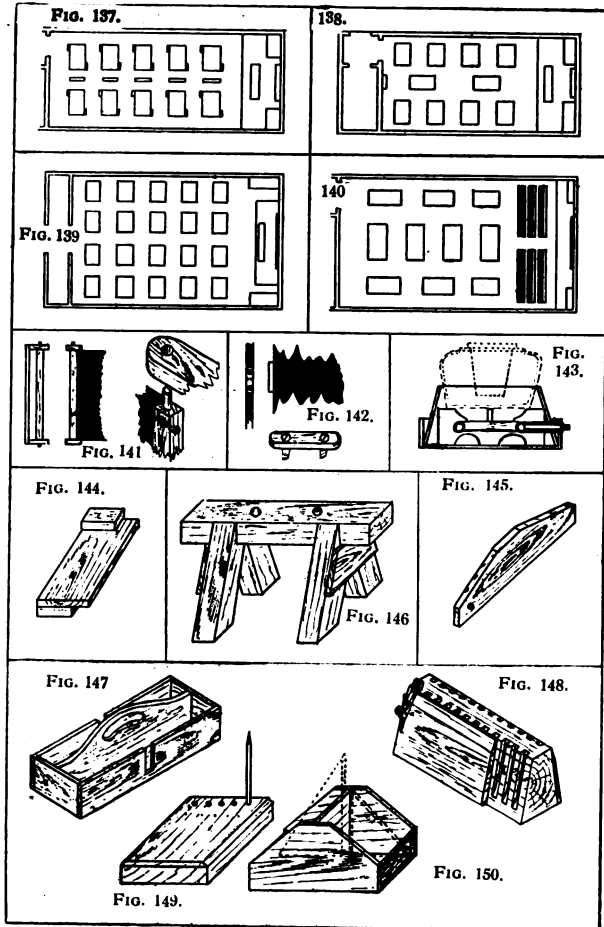

822744

the floor, and provided with Parkinson's instantaneous grip vice, and a stop adjusted by a cam.

*Tool Racks.*—These should be constructed to hold all the tools needed by each boy, and nothing could be better than the style adopted generally at the London School Board centres (Fig. 151). A rack of this description is far away in front of drawers, the tools being kept in much better condition, always in full view, and very easy to get at. The various tools which are not in such general use should be arranged on the lines shown in the photographs (Figs. 152 and 153), and a very nice effect can be given to the room by a display similar to these. The method of displaying tools has great advantages over a cupboard, for if occasionally the tools are rubbed over with a vaseline rag they will not rust, they are always accessible, and a glance round the room will at once show if there are any missing.

*Blackboards.*—These, always being in use, should be hung in prominent places, and by adopting the plan of hinging them so as to make them revolve, a great saving of space is effected, for by being able to quickly turn the board it saves having too many boards, and bring both sides quickly into use. Figs. 141-2 explain the ways of doing this, and of fixing hinged boards for showing the planes of projection; this arrangement should be fitted to each board, and either one or two spare boards kept ready to hinge and hook on.

*Cupboards* may be dispensed with if shelves fitted

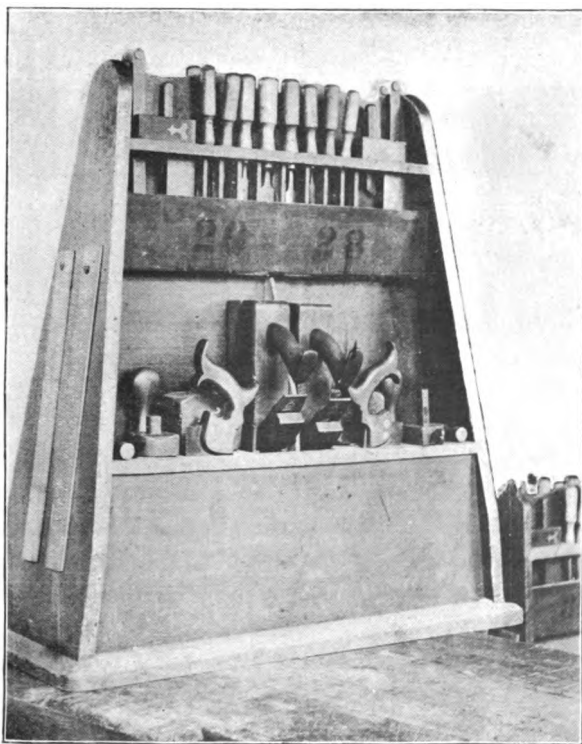

FIG. 151.



with doors are provided, but a glass-fronted cupboard for exhibiting specimens would be an ornament.

*Shelves.*—These should, as far as possible, be fitted with doors or movable fronts, and labelled with names of their contents, a separate compartment being kept for each class, with divisions for work and drawings.

*Sawing and Boring Stools.*—Figs. 146 show the recognised design for these necessary pieces of furniture, the hole in the end being useful both in sawing and boring by providing a means of using the holdfast.

*Storage of Timber.*—Whenever possible the timber should be kept in a separate room, as it is always difficult to keep it tidy, but if this is impossible shelves should be fixed near the ceilings or out of the way, and only a small quantity kept in the room in a rack built in a corner or some other convenient place.

*Gluepot.*—This should be placed in a prominent place where the use of it can easily be supervised. There are many ways of heating it, but the one illustrated (Fig. 143) provides a very safe and convenient way, and concentrates all the heat on the bottom of the pot.

*Benchhooks (Fig. 144) and Paring Boards* are quite necessary for each bench, and should have their proper place.

*Straight Edges* should be also provided for each bench, and either hung on the bench or tool-rack. They are best when made of mahogany or walnut about  $\frac{1}{4}$  in. thick, and of the design shown in Fig. 145.

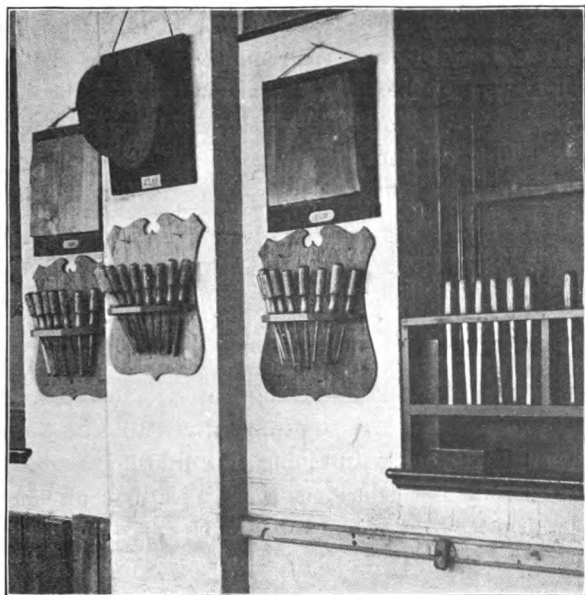

FIG. 152.

*Brushes* for every bench, too, are useful, and leave no reason why the bench should not be left quite clean at the end of each lesson.

*Drawing Materials.*—Again the necessity of a methodical arrangement presents itself. The drawing board, and tee-square (which should fit under the board), are best fitted in a groove beneath the bench, they are out of the way and it saves the room that a lot of stacked boards would take. The set squares should be kept in a case like Fig. 150. Pencils which are generally more often lost than not, if arranged like Fig. 149 will pay for the little trouble involved in making the stand. Rulers again will keep their edges longer if arranged in a box constructed on the lines of Fig. 147, and there is no method of holding compasses better than that illustrated in Fig. 148. All the above methods greatly economise space and time, and save a deal of wear, for nothing wears drawing materials out so much as throwing them carelessly into a drawer, not to count the great help in maintaining the orderliness of the room, for when it is evident that a place is provided for each piece of apparatus, bad habits of disorder are never formed.

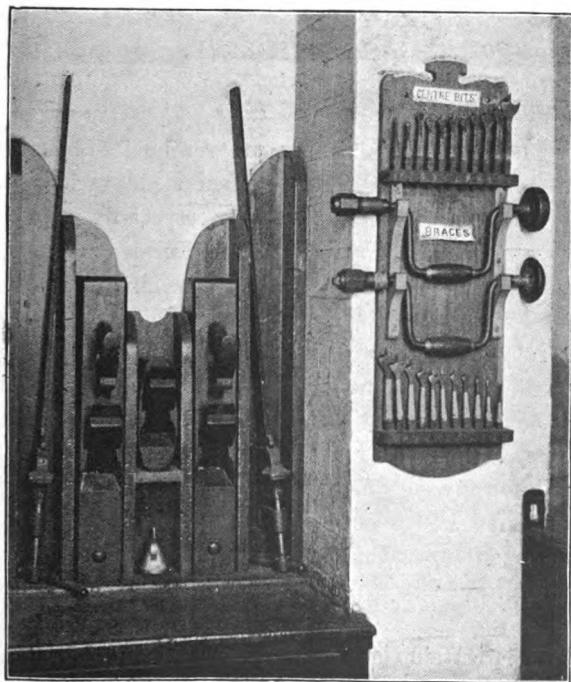

Fig. 153.

## CHAPTER V.

---

### DISCIPLINE.

---

There are probably no other school subjects that centre a child's interest so much as the various forms of manual training, and more especially woodwork. It allows full scope to that natural energy which every child possesses. Under these circumstances the need for severe discipline should be slight.

A well-organised scheme of work will prove the greatest possible help, in the fact that while the boys are under instruction they should have employment for every minute. It is against a child's nature to be kept still for any length of time without something to occupy the mind, and a good scheme would leave no time unoccupied other than a few minutes at the beginning and end of lesson for the distribution and collection of work.

It is certain that the teacher who has the power of turning that natural energy and activity into account has solved the problem of the successful management of children, and when one considers how easy it is to get a boy's whole attention fixed on his work, it is surprising to hear of many cases in which the teacher

is deficient in disciplinary powers ; of course there are often cases of laziness and wilful inattention which must be treated in other ways, but these may sometimes be traced to an inability to concentrate the brain, indicating a certain amount of weakness, which will be overcome in time, if carefully treated. There are again some children who do not like the work the class is doing, and in order to claim their attention another model should be designed likely to interest them ; one thing is certain, that if only a boy's interest can be gained, and his whole attention rivetted to his work, he is not at all likely to become troublesome.

*Example.*—This is another great aid to discipline, and one not sufficiently studied. We see the effect on the child of his home life, and the value of the example set by his teacher cannot be over-estimated ; for if the instructor is kind, good-tempered, fair in his judgment, refined and straightforward, his pupils cannot fail to derive some good from their association with him.

A teacher cannot think of his own life only, he has in his charge, only for a few hours a week perhaps, the men of a future generation, but in that time he is able to train habits of carefulness, order and truthfulness ; and he may prove a greater power in the moulding of their character than he may ever imagine. His actions and words are constantly being noted, and used for and against him continually, and great care should be taken that no wrong impression should be given.

*Praise and Censure.*—How often does a teacher forget to praise a pupil's work or behaviour when it is deserved? and yet he would expect it himself; for no man would care to remain long in any position for which he was never given any credit, never congratulated on the results gained; and much more is that feeling to be worked on in children. A well-timed word of praise or censure will do a great deal in attaining a good discipline; but it must be used with great discretion, for too much of either is worse than none at all, and it will be found that a good disciplinarian will effect as much with a little censure, as some men will do with much harsher treatment.

*Emulation.*—This spirit may be used to great advantage with many children, but it must be very carefully fostered. It will be for good if guided by a kind and generous mind, but may have quite the opposite effect by training a feeling of contention if the guiding mind is other than broad in its views.

Some authorities have written against it, and consider that it would be infinitely better if never used, but Currie in his *Common School Education* says: "As a principle consciously directed by the enlightened teacher, it is a power in the school, capable of attaining great results, without injury to the moral feelings of those stimulated by it," and indeed if the spirit be well-trained while the boy is at school, there is no knowing the benefits he may derive from it in his future life.

*Punishment.*—It cannot be denied that in some instances impositions and corporal punishment are necessary, but it takes a long experience to tell when to inflict bodily pain as a punishment. It should only be resorted to as a last extremity.

Often sufficient punishment can be inflicted by means of impositions, deprivation of playtime, and detention after school, but each case should be considered on its merits, and punishment often avoided by placing the offender out of temptation under direct observation.

To some children the loss of their playtime is much more to them than bodily pain, and if this is accompanied by some drill or physical exercise it will have a good moral effect.

When other means have ended in failure, corporal punishment must be resorted to if the discipline is to be maintained. Currie says: "In admitting that the action of this punishment will be found salutary in certain cases, we hold that in a good system of discipline it will be altogether a rare and exceptional resort. It may be well to recapitulate the means of influence whose use should make it so; the general work of the school should be made interesting by appealing to the pupil's intelligence and engaging his activity. Then the teacher should deal with him generously, regulate exactions by the power of performance; manifest a desire to have the pupil on pleasant terms with himself rather than to catch at his



failings, and find in them opportunity for censure; appeal to his better feelings, and rely on them as long as they appear sufficient; concern himself with his general welfare and happiness, and when difficulties arise, deal with him openly, justly, and resolutely. He may thus hope to establish for himself a strong personal ascendancy over his pupils which will make itself felt to the furthest limits of their duty, and in his school a healthy public opinion which will dispose all to be guided by him, to regard not only his regulations but his wishes as their law, to covet his approbation as their highest pleasure, and to shrink from his censure as the source of their greatest uneasiness. If, in addition to all this, he sets before them a good and consistent example he has in operation a series of educative influences which will, in the general case, keep the moral machinery of the school in sound and vigorous operation, and which will keep punishment in the subordinate place which belongs in education to corrective stimulants as the remedy for exceptional and abnormal acts and dispositions. When he has done all this the minor penalties still stand between him and chastisement. Let him not make up his mind to the use of chastisement as a matter of course because thousands before him have done so, but let him act on the conviction that other means of influence and restraint are open to him which, as many have found sufficient for their purpose, he may find sufficient for his. Let him aim at prudence, patience, firmness,

and dignity in administering these ; prudence, to adapt them in kind and degree to the various offences he has to check ; patience and self-control to restrain the passion of the moment, and to exhaust the influence of the minor penalties his law allows him ; firmness, to disregard the promptings of partiality on the one hand, and of caprice or humour on the other ; and dignity which shall banish from the judgment-seat everything like a flippant and jesting spirit in the serious work of discipline. Let him keep note of his experience in the use of all his influence, and let him study the character of children that he may gain an insight into their motives. The better he knows them the firmer will be his hold over them. He may hope to learn the mechanism of the child's action so well as to obtain almost the complete power of regulating it. He will then be able to retain chastisement as a reserve-force, which is precisely his position of greatest influence. Its power is in the inverse ratio to its frequency of application. Where it is employed for every-day acts it becomes a common thing with a common-place influence, and the result of familiarity with this the lowest of all motives is to weaken or destroy the force of the higher. He uses it best who uses it least, not because, like a servant, he is forbidden to use it, but because with the dignity of a free agent reserving the liberty of its use he has learnt to do without it."

## CHAPTER VI.

---

### ORGANISATION AND METHOD.

---

The importance of good organisation and the best methods in teaching cannot be over-rated. It is impossible to design a scheme of woodwork that would meet all cases as the individuality of students or the needs of various districts have to be considered, so every instructor must of necessity be able to adapt and mould the subject accordingly, and must know something of the main principles of organisation and method.

There are many excellent books published on school methods, and valuable hints may be gained from them, but little has been written with regard to teaching woodwork.

*Classes.*—In many large School Boards, classes of forty boys attend a centre for instruction and these are generally drawn from surrounding schools; the centre is placed in charge of a well-qualified instructor, with an assistant. This places the former in a much more responsible position than if alone with twenty

boys, as is usually the case ; for he has not only the organisation and disciplining of a larger class, but in many instances the training of his assistant. In most cases this is an excellent thing ; it is not only economical, but it gives the assistants a good hold of the work before taking charge of centres themselves.

The large centres are not, however, always as successful as the smaller ones, mainly owing the defective organisation of the work ; too much work is often deputed to the assistant, who is perhaps not quite capable of taking the responsibility of unaided work, and in many cases he is placed in charge of the new and dullest boys in the class. Now in a well-conducted centre the instructor would avoid anything of this kind, for he would know that it is the beginners and dullards who need the best teaching, and that is presumably given by the instructor himself, and it is certainly in the beginning that good or bad habits are formed, and a zealous teacher would never lose an opportunity of pointing out the right way to those beginners. The best arrangement is to give the assistant charge of the best boys in the class, those who only need a little guidance, and this would leave more time for the instructor to devote to the younger pupils.

*Time-tables.*—To ensure punctuality and order, and avoid confusion, time-tables are quite necessary, and it is a fact that certain things are done at stated times, unconsciously train in the boys a sense of order.

The time devoted to manual work varies much, from 1 to 2 hours in a grammar school, to  $2\frac{1}{2}$  to 3 hours in elementary schools.

*Drawing.*—This is usually taken first, for several reasons; it may be that new work is required, and enough drawing should always be done to insure a full amount of woodwork; also for the sake of cleanliness, it is better to start with drawing; however clean the room may be the boys cannot help soiling their hands.

In many manual training schemes drawing occupies a very second-rate position, but it is quite as important to grade the drawing as well as the woodwork. As the benchwork increases in difficulty so also should the drawing, but if it is taken regularly there should be no trouble with it.

Great attention must be paid to the preliminary work to ensure a good command over the set square and ruler, and the various drawing tools should be in good order; these should be overhauled at regular intervals, the angles kept true and the edges straight, and most important of all, the pencils should be sharply-pointed. The majority of faulty work in drawings can be traced to blunt pencils, and it is a good plan to have a pencil-sharpening machine, and keep a good stock of ready-sharpened pencils. The use of rubber should be avoided as much as possible. The effect of indiscriminate use of the rubber has quite as bad an effect on the drawing as glasspaper has on benchwork, and the one should be shunned as much

as the other. The aim of the teacher should be to get a fine light line at first, and then line in the required parts, if this is done from the first the use of rubber will not be required. A set of the first few exercises should be made double size, and the sections cut through to use on the hinged blackboard. It is also useful to have a few of the ordinary geometrical models, such as the cube and various prisms.

*The materials* used must be carefully considered, and it is ruinous to good work if common material is used. This is particularly the case in drawing; the lead in the pencil should be of good quality, made by a well-known firm, and preferably should be a H, and the paper which is usually used in the form of books should be a good stout cartridge about 14in. by 10in. The advantage of having books lies in the fact that the drawings can be kept together, but if loose sheets are used or sketch blocks of cartridge paper, a brown or thick paper envelope should be made to keep the loose sheets in.

*The Blackboards* should be as many as possible and arranged in the most convenient places, and wherever most convenient a hinged one should be fixed, so as to be in full view of the whole class, with the hinge about the level of the boys' eyes. The blackboard work should partake more of the quick sketching style than elaborate drawings to scale. It is advisable at first to draw with a ruler and set square, but when the drawing is a little advanced a dimensioned sketch is

all that is necessary. The instructor should himself practice blackboard drawing, and would find a course of work in it very useful.

*Drawing Boards, etc.*—These should come into use in the second year, and their advantage will then be felt. It is not advisable to commence with them, otherwise the training given by the use of the ruler and set square would be lost. Half Imperial size is best for all-round work, and is just large enough to give the boys an increased difficulty to overcome. The tee square should be a plain blade, screwed on the stock, and arranged so as to be kept under the board by means of a groove in the battens.

*Benchwork.*—As the greater part of the lesson should be devoted to benchwork, a considerable amount of forethought will be required to ensure that each boy's time is well occupied. There will be no temptation to idleness if sufficient work is provided. A wise discretion, too, must be exercised in the choice of models, for many cases will occur where the scheme model is unsuitable, and a new one should be designed to take its place; here a note-book is essential to jot down the peculiarities of the various boys and their needs in the shape of work, this should be looked over after the lesson and new work prepared for next time. *It must be remembered that although much teaching may be done collectively the important work is done individually, and the requirements and character of each pupil must be studied if success is coveted.*

To lay down an unalterable course of work would be folly, for a large amount depends on the individual capacity of the student. While the scheme of work given in this book will be suitable to a large proportion of children, there are sure to be many for whom it will have to be altered, and it should be remembered as an important fact that *no student should be allowed to pass to the next stage without making a satisfactory piece of work in the stage in hand*; another model based on exactly the same manipulation should be given in case of failure.

It is a common practice to have teaching models of the class model worked out in several stages, it has however little to recommend it, and may profitably be omitted in place of several practical demonstrations on the part of the teacher himself. It will help him in maintaining the respect of the child, and will certainly keep up his own hand skill, in addition to the great help it will give to the student; they see the proper methods of holding tools, and correct order of the various manipulations. It is a good plan for the teacher to start each piece of work with his class, and work it out a little in advance of them, but not on any account to make any difficult model at one demonstration, but take a stage at a time.

Great attention must always be paid to the state of the tools and bench, a little carelessness in attending to this will result in bad habits being formed, most difficult to break. If the students are



trained from their first lesson to take care of their tools and keep them in order on their bench, they will form a habit of it. It is not advisable to have more than the tools actually being used on the bench at one time. For instance in planing, first the plane, square and rule, and when required add the gauge, but directly the work is finished these tools should be replaced by those needed in the next stage and so on. There never need be more than three or four tools on the bench at any time.

Sharpening is a problem which confronts all teachers, and a method should be organised for it. It is not advisable to allow first-year boys to do their sharpening, but all second-years and upwards ought certainly to sharpen each tool before use. I allude, of course, to planes, chisels, gouges, etc. ; the saws should be set and sharpened by an experienced man. A time-table should be arranged so as to take all grinding in turn, if it is done at the centre.

A definite arrangement must be made for entering and leaving the manual training room, and the distribution and collection of material and work. The boys should be made accustomed to certain precise words of command, and even in this way a liking for order may be trained, for it is even better to lose a little time than have confusion ; a properly-constructed time-table would allow for this, and it should be strictly adhered to.

*Object Lessons.*—These are quite an important part

of manual training, but are often spoiled, and just as often totally omitted, but considering the fact that they should never exceed ten minutes, it is a very small call on the attention of the boys; they are best arranged as a little relaxation from the benchwork, and should be made as interesting as possible.

It is a great mistake to occasionally give long lectures on the various timbers and tools. Much more good can be done if the lessons are given regularly, and occupy only a few minutes. Here the advantage of rapid blackboard sketching will be seen, for a few sketches will illustrate a point far quicker than any explanation.

## CHAPTER VII.

---

### THE INSTRUCTION OF THE PHYSICALLY AND MENTALLY DEFICIENT AND BLIND.

---

The extension of the benefits of manual training to those children who are afflicted with deafness, blindness or a poor intellect, has only been attempted in a few large towns. This is mainly because the majority of instructors have had no experience, and no knowledge of the best methods of teaching such children.

There is no other subject capable of enlarging their intellect in such a way as manual work. The outlook of these poor children is in many cases very dark, but a good deal may be done for them while at school, for their hands may be so trained as to make them capable of earning a living by manual labour.

The course of work designed for such children should commence very simply with a course of paper and cardboard work, following with strip work, and then simple sawing and grooving.

The deaf, deaf and dumb, and other physically

FIG. 1. Letter T. FIG. 2. A Square. FIG. 3. Letter L.  
 FIG. 4. Letter E. FIG. 5. Letter H. FIG. 6. An Easel.

FIG. 6.

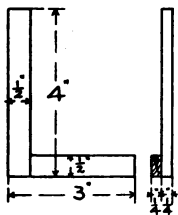
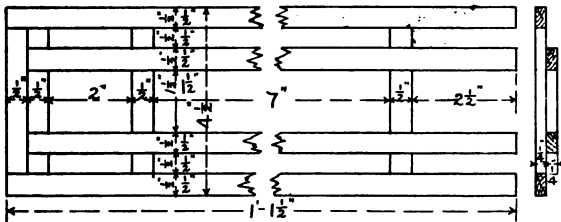

FIG. 3.

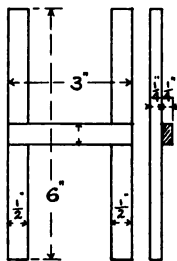

FIG. 5.

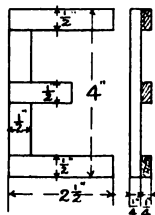

FIG. 4.

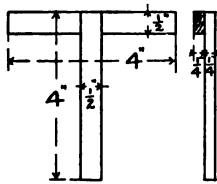

FIG. 1.

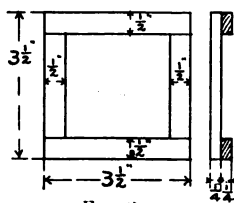

FIG. 2.

COURSE IN STRIP WORK.—I.

defective children may be taught together, but a different system must be used for the blind.

The paper and cardboard work should be so designed to give a good idea of shape and size, and the strip-work, with its training in the use of the rule and saw, will prove invaluable in the woodwork course. The latter form of manual work may be taken by the woodwork instructor, but is better if it is carefully given by one of the usual teachers, because of their power to impart to their pupils idea of size and proportion, as well as being better able, owing to their special training and constant intercourse with their children, to teach them the elementary stages of the work.

If properly taught, stripwork, as an introduction to woodwork, has many advantages. The children can commence drawing, and learning the use of the rule, square, saw, bradawl and hammer, and a well-designed course will make them appreciate the value of being able to make a joint. The outlay, too, for such work is only slight, and as it may be done on a bench temporarily placed in the ordinary classroom, it is a very convenient system of training.

A brief outline of the work, the tools needed, and methods of working will be useful.

Each child should be provided with a rule, saw and square. *The rule*, either of wood or steel, should not have more than eighths marked. An illustration is given (Fig. 163, page 127) of a wooden rule, the divisions of which are alternately coloured.

FIG. 7. An Oxford Frame. FIG. 8. A Ladder.  
FIG. 9. A Rack;

FIG. 9.

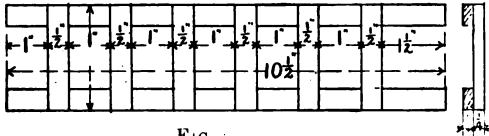
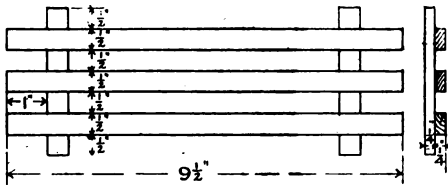

FIG. 8.

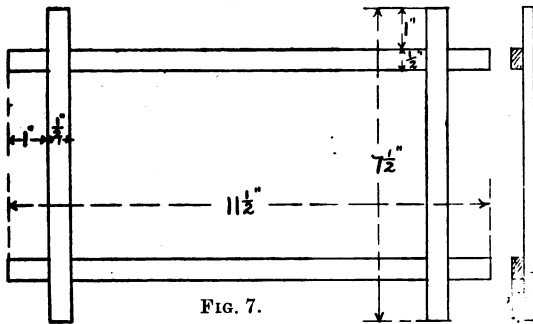

FIG. 7.

*The saw*, not the ordinary tenon, but a small dove-tail saw, which will only be needed to cut thin pieces of wood about  $\frac{1}{4}$  in. thick.

*The square* should be of the ordinary pattern, about  $4\frac{1}{2}$  in. and a few small hammers, bradawls, and brads for general use. Small sawing boards will be needed, and they should be a little smaller than those used in the woodwork course. The bench, owing to the light work done, will undergo no great strain, and could be a board fitted to the class-room table with the pupils ranged around it, and as the numbers should never be above ten, an ordinary sized table would easily accommodate that number. The wood used should be some soft timber, such as pine or satin walnut, preferably the latter, for although it is very much given to warping, it offers just as much resistance to the saw as the children are capable of, and will not easily split if carefully bored before the brads are driven in. A stock of strips about 2ft. long and  $\frac{1}{4}$  in. square,  $\frac{3}{8}$  in. wide and  $\frac{1}{4}$  in. thick,  $\frac{1}{2}$  in. wide and  $\frac{1}{4}$  in. thick, and some 1 in., 2 in. and 3 in. wide strips of  $\frac{3}{8}$  in. thick should be provided.

The course of work should comprise sawing into various lengths, and making such shapes as squares, oblongs, and then small articles as frames, gates, small racks, easels, ladders and other such plain models, and leading on to more advanced work. The accompanying illustrations (Pages 121 and 123) give a good idea of the course which is progressively designed by Mr. C. Winter.

The woodwork course should be a modification of the ordinary one, with a greater variety of the elementary work in sawing, chiselling and planing. A first-year's course should start with planed wood, and only include in the first exercise marking off with the square and sawing, and gradually introducing the gauge, chisel and plane. The second-year's course and upwards will depend on the intelligence of the child, and must be framed accordingly.

A suitable series of exercises for a first-year's course are given, and they should be taken as carefully as possible, impressing on the children the importance of doing each step properly.

### 1st EXERCISE. (FIG. 154.)

*Drawing.*—A front side or top and edge view of the wood (Fig. 155), with the lines across. Fig. 163 shows a suitable form of rule.

*Woodwork.*—Give each pupil a planed piece of wood about 12 inches, and show how to use the square. They should do each step after the instructor, at first mark off the nine lines, and then placing the wood on the sawing board, and the saws in position have one piece sawn off. Now the squareness of the cut should be tested by standing the long piece upright on the newly-sawn end, this will show at once if the cut is not square. Continue until all the pieces have been sawn and placed one by one on the drawing.



**2nd EXERCISE.** (FIG. 156.)

*Drawing.*—The drawing of this exercise will be a little more difficult, but if the actual exercise is placed before them it will be more quickly understood.

*Woodwork.*—A 12in. piece of planed wood as before, and with less instruction, but as much careful supervision, let each length be sawn off and placed on the drawing.

**3rd EXERCISE.** (FIG. 157.)

*Drawing.*—This drawing should be similar to the previous ones, but show a difference in representing on paper the finished exercise, for in the previous drawing the upright lines were projected straight down to the plan, but in this one it is a little different, and the lines represent the length of the pieces instead of the thickness.

*Woodwork.*—Planed wood as before, and even less instruction, for the children by now should be able to make a very square cut to any length.

**4th EXERCISE.** (FIG. 158.)

*Drawing.*—There is no increased difficulty in this drawing. (Fig. 159.)

*Woodwork.*—Planed wood as before. In this exercise the gauge and chisel are introduced. Their use should be shown, and each stage carefully demonstrated. Then placing the wood in the vice the cuts should be taken slowly and carefully.

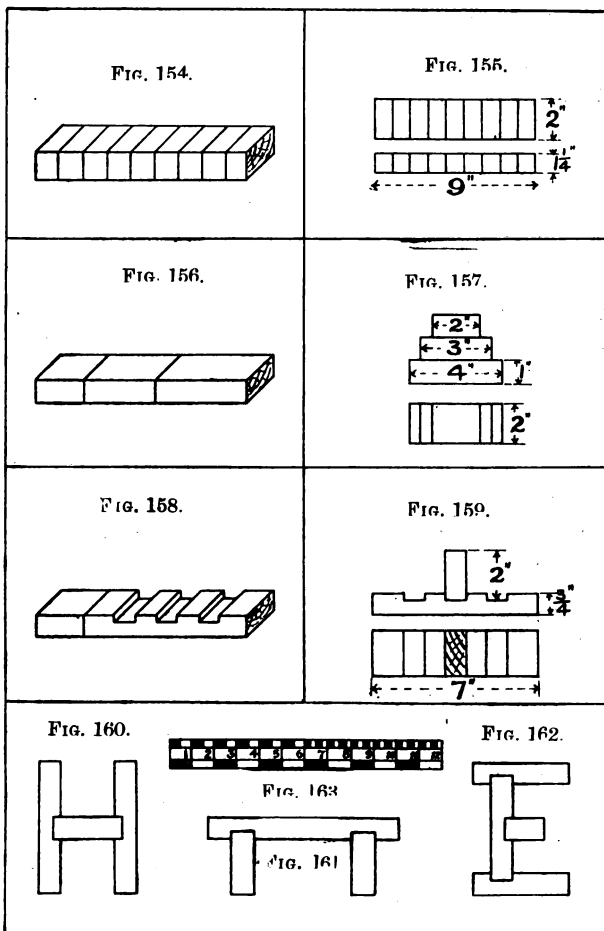

**5th EXERCISE.** (FIG. 160.)

*Drawing.*—A little extra work will be experienced in this drawing, but it is not any more difficult.

*Woodwork: Planed Wood.*—In this exercise there is no new operation, carefully mark out and saw the first groove, then with frequent demonstration cut each groove. It will be found that the children will be getting a very much increased interest in their work, and will probably want to rush through it, but they must be carefully looked after so as to ensure a good exercise.

**6th EXERCISE.** (FIG. 161.)

*Drawing.*—This should prove easy, and finished with very little assistance.

*Woodwork.*—Planing may here be attempted, but if the children are feeble or particularly dense, it may be left much later. The other work would be done very quickly.

**7th EXERCISE.** (FIG. 162.)

*Drawing.*—Care will have to be taken that the lines are kept upright.

*Woodwork.*—This is only a little more work than the previous exercise, and all the grooves should be cut before sawing apart. It will be found a very interesting exercise.

These exercises would give enough work for a year, but if any more were needed they might be taken

from the ordinary first-year's course, and it will be found that with a careful training such as above, the models of the first year might be taken (with some modifications) as a second-year's course. In any case where the exercise would prove too difficult it will be possible to simplify the work considerably.

*The Blind* must be treated quite differently, and it is best to start with planing and get them used to a true surface. It will not be found difficult to teach them this operation, for they can test their work by placing it flat on the bench and feeling for unevenness, and for squareness by placing it against the square. In sawing, notched sticks must be made to act as gauges to start the saw-cut, and if a series of notches are cut at certain distances and a deep gauge line made, it will be found possible for blind boys to do grooving as well as planing, and gradually lead on up to joints, for it is astonishing how quickly these boys work when they have once got hold of the principles.

## CHAPTER VIII.

---

### OBJECT LESSONS.

---

These lessons form an important part of a manual training scheme, and are often not given at all, or perhaps only occasionally without any method.

Nearly one hundred headings of lessons are given below, spread over a three years' course, and several of them will be found illustrated with sketches suitable for reproducing on the blackboard; only the important items have been touched upon, and further information if required, may be found in the various books on timber, etc.

A collection of the apparatus should be gathered together and arranged in order in a cupboard.

The duration of an object lesson should not be more than ten minutes, and, to afford a rest, is best taken in the middle of the woodwork lesson.

Whenever possible the experiment should be performed by all or at least some of the boys, and every opportunity taken of demonstrating some fact connected with the work in hand, that they have learnt from these lessons,

**Object Lessons. First Year.**

1. *Set Squares*.—Size of angles and divisions of circumference. Experiment to prove that three angles of any triangle equal to two right angles. Cut out a triangle in paper, cut off and pin the three angles on the board; they will, at the base where the angles meet form a straight line.

2. *Yellow deal*.—Wood of Scotch fir or northern pine. Grows in northern Europe. Called yellow deal because of the colour and form in which it is imported. Most commonly used for building, etc.

3. *Fibre and grain*.—Exhibit skein of string and husk of cocoanut, and explain that the structure of timber is not unlike examples. A chisel will part fibres if placed along the grain, but will cut them if placed across.

4. *Tenon Saw*.—Explain parts: Handle of beech, blade of thin steel, and back of iron or brass. *Beech* used for its toughness and strength in short grain. *Blade* indented with teeth, which are sharp and given a set. *Back* to give stiffness to blade and sufficient weight.

5. *Care of Tools*.—Explain delicate edges of cutting tools, need to protect these edges from injury, necessity of keeping only those tools needed on the bench, and to have a certain place for each tool.

6. *Chisel*.—The *handle* of hardwood, such as ash or beech; *ferrule* of brass to prevent handle from splitting, and *blade* of steel with a shoulder to prevent

blade being driven into handle. Ground on one side to a bevel, and sharpened on an oilstone.

7. *Gauge*.—Used for marking parallel lines along the grain. It parts the fibres. Composed of four parts, each beginning with an S. *Stock* and *stem* made of beech; *screw* made of boxwood; *spur* made of steel. The stock may be moved along the stem, and fixed at any distance away from spur by the screw.

8. *Jackplane*.—Derives its name from the fact that it does the rough work, a jack of all planes. Composed of wooden body made of beech and steel cutte or blade. The blade or plane-iron is adjusted or set by means of hammer and mallet, and fixed by a wedge.

9. *Basswood*.—Grows in North America. A soft wood of a green colour when freshly cut, but with exposure turning brown. The tree is similar to English lime, but is very much larger, and from the inner surface of its bark comes the bast fibres used by gardeners and others, and for making matting.

10. *Straight Edge*.—Explain how to test for straight edge by sight, and by putting two edges together. Give Euclid's explanation, and show by experiment with two long nails, and some string, that the string is only straight when most tightly stretched, and therefore the shortest distance between the nails.

11. *Polygons*, meaning a figure with many angles, and therefore many sides.—Draw the various figures from triangle to Dodecagon, *i.e.*, square, pentagon, hexagon, heptagon, octagon, nonagon, etc. Prefix giving

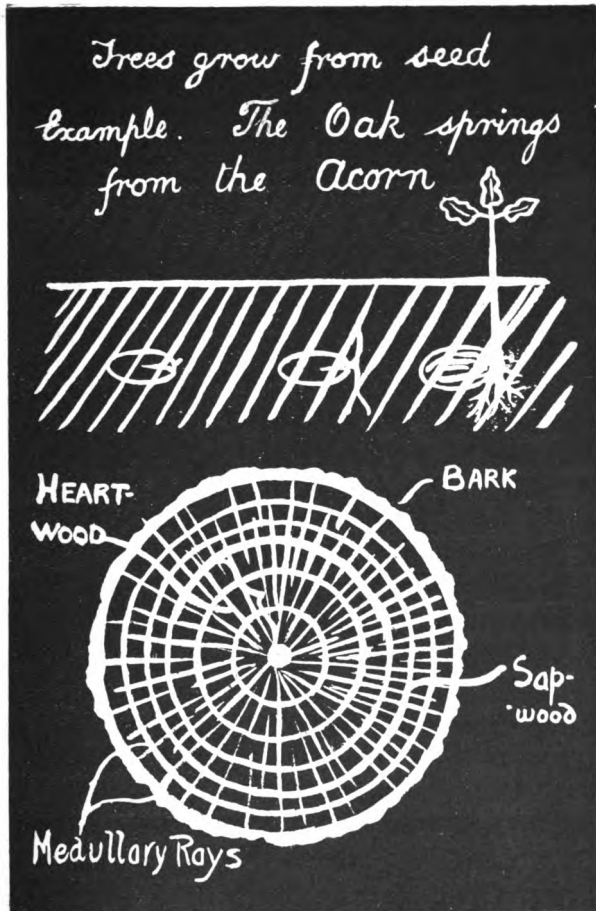

SPECIMEN BLACKBOARD ILLUSTRATION.

(Object Lesson No. 15).



Latin number before "gones" meaning an angle (*n. b.*, dia-gonal=across the angles).

12. *Cutting Edge*.—Explain that the finely-sharped edge of a cutting tool is called the cutting edge, and steel is the only metal which will retain a sharp edge. It needs constant sharpening, and when angle is "obtuse" needs grinding to make it "acute."

13. *Pencils and their manufacture*.—A case explaining the mode of making pencils should be procured, and if each step is explained from the examples there will be no need of further explanation here.

14. *Parts of Jackplane*.—Exhibit a section of the plane, which can easily be made from an old plane if it is sawn in half and the iron divided by means of cold chisel. The body, handle, and wedge made of beech-wood, because of its strength, even texture, and closeness of grain; the cutting iron made of iron, steel faced; cap iron made of iron, held together by means of screw.

15. *Growth of Tree from Seed*.—Show by illustration the way the seed sends forth shoots, and how root works downwards while branch works upwards, and gradually the seed decays, its purpose fulfilled, and both root and branch increase in size as nutrition is found.

16. *Use of Cap Iron*.—Show by means of diagrams the way cap iron breaks the shaving. The object is to prevent the cutting iron splitting the fibres by breaking the fibres in the shaving as soon as it is cut.

17. *Screw driver*.—Used for turning screws, and com-

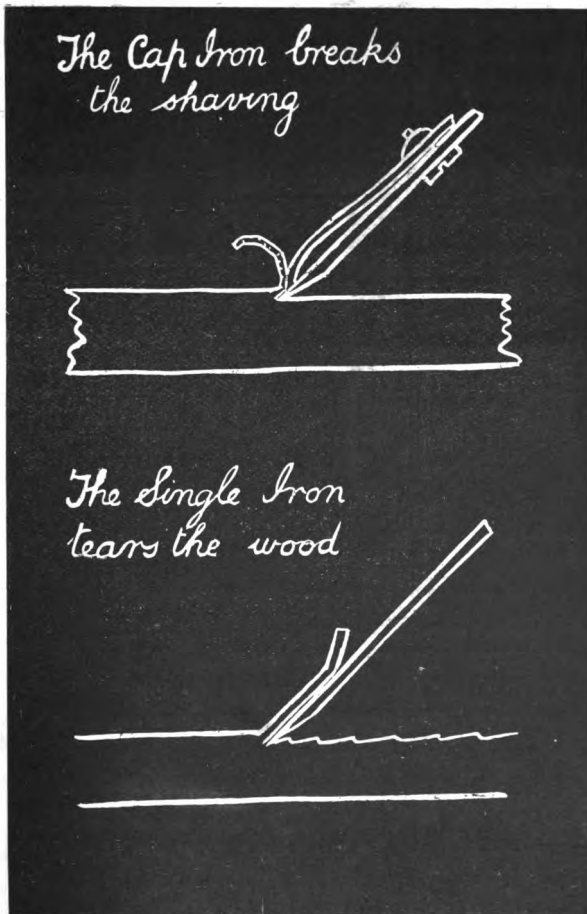

SPECIMEN BLACKBOARD ILLUSTRATION.

(Object Lesson No. 16).

posed of three parts: *Handle*, made of beech or other hard wood; the *brass ferrule* to prevent blade being driven in, and giving strength to the handle, and a *blade* which is flattened out near the top, and has a "tang" and shoulders which fit into the ferrule to prevent the blade twisting about. It is a form of *lever*.

18. *A Plane Surface*.—Explain that the surface of still water is practically plane, but differentiate between a plane and a level surface.

19. *The Cutting Iron*.—Show how this is composed of both steel and iron welded together; and the reason for this is, that it is both easier to grind and that it renders the blade cheaper.

20. *Products of Pine Trees*.—Provide a few test tubes, place in them some of the products, and arrange them on a stand. *Liquids*, turpentine, Stockholm tar, and gum. *Solids*, resin, charcoal, and potash. Explain how turpentine is distilled from resin, and its various uses, as well as those of the other products.

21. *Battens, Deals, etc.*—Explain how the timber is cut up and shipped in various forms. *A Plank*, from 8ft. upwards, 11in. broad, and up to 6in. thick. *A Deal*, from 8ft. upwards, 9in. broad, and up to 4in. thick. *A Batten*, from 8ft. upwards, 3in. or 4in. broad, and up to 1in. or 2in. thick. *Balks*, squared up timber of large size. *Logs*, roughly hewn pieces of timber, usually round.

22. *Try-square*.—Used for trying the squareness of

the work. Composed of three parts :—A *stock* made of rosewood and ebony, brass plate or fence on the edge to prevent wear. A *blade* made of steel with trued edges fixed into the stock at an angle of 90 deg., or a right angle.

23. *Conifers*.—Explain that this is the name given to that branch of trees which bear *cones* and have a narrow needle-pointed leaf. Exhibit some cones and leaves of one or two kinds of conifers.

24. *Hand-saw*.—Show that the hand-saw is used principally for sawing down the grain to any depth. Compare parts with tenon saw, and show difference in handle and blade, and explain in many cases top of blade is thinner than that near the teeth.

25. *Nails*.—Provide a number of different nails, cut wrought, wire, brads, and tacks, and explain the various uses and manufacture. *Cut nails*, stamped out of sheet iron or steel. *Wrought nails*, hammered from iron. *Wire nails*, made from iron or steel wire. Experiment with specimens, and show their effect in the wood, and explain how the fibres hold the nail.

26. *Pines and Firs* are different kinds of conifer. Illustrate the difference between a pine tree and fir, and show the shapes of leaves. Show that the Scotch fir is wrongly named, it is really a pine.

27. *Hammer*.—Show the two parts, the *handle* of ash, because of its flexibility, and explain the effect if a flexible material were not used. The *head* of steel. Show the way the “eye” of the head is made,

and the use of the wedge driven into the end of handle. The upper part of the head is called the pane, there are *cross* (the usual pattern), *straight*, and *ball-paned* hammers.

28. *Sapwood and Heartwood*.—Provide specimens containing examples, and show difference in colour, and explain why sapwood, not being fully formed, should not be used, and that the heartwood is the only durable portion of timber. Explain that the sapwood in its turn becomes heartwood.

29. *Mallet*.—Explain the need of mallet, and difference in blow given by it to that of a hammer, the latter rebounding, while the depth and size of the head of a mallet offers a resistance, and renders the blow dead. Take the handle out and show the direction of taper in the mortise and handle, and which causes the head to tighten with centrifugal force.

30. *Broad Leaf Trees*.—Exhibit some leaves of broad leaf trees, and explain that the great difference between them and conifers has resulted in the name. Show, however, that they both belong to one division of trees, but form a sub-division with conifers.

31. *Bradawl*, composed of three parts, very similar to the chisel. A handle, ferrule, and blade with shoulder and “tang.” Explain the edge is sharpened on both sides, and should cut across the grain. Give practical illustration.

32. *Annual Rings*.—Provide a specimen of larch in which the rings are well marked, and explain the

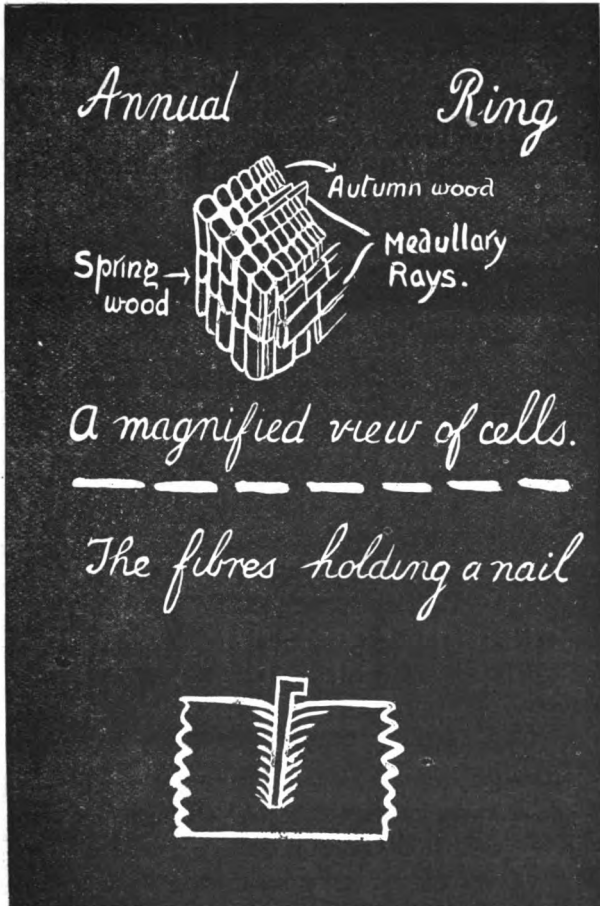

SPECIMEN BLACKBOARD ILLUSTRATION.  
(Object Lessons Nos. 25 and 32.)

growth of the tree year by year produces a new ring commenced by the loosely-built springwood, and surrounded by the harder, and more closely-formed autumn wood.

38. *Pincers*.—Composed of two parts, which are practically alike and made of steel, rivetted together, and capable of bearing a big strain. They form an excellent example of the lever.

### Object Lessons. Second Year.

1. *Tee-square*.—Explain its construction and need of great care in use to prevent it getting out of truth.

2. *Walnut* grows in England, Europe, and the United States of America. The English variety is a light brown colour, but the American is of a purple black. Walnut has a beautiful grain, and is a hard wood with fine close fibres, and even in texture. It is noted for the fact that it does not shrink or warp after seasoning, and for this reason, coupled with the absence of any corrosive action on metal, is used exclusively for gun stocks. It is principally used for furniture and ornamental work.

3. *Spokeshaves* are made both of wood and metal: *Wooden spokeshaves*, made either from beech or boxwood, and fitted with a steel blade which has a tang at both ends to fit into the stock; *Iron spokeshaves*, the stock is made for cast iron, and the blade is similar to the cutting-iron of a plane screwed on to the stock, which is sometimes fitted with a screw adjustment.

They are similar in action to a plane, and used for planing curved surfaces, and are very useful. Show differences between each kind and ways of adjusting the iron.

4. *Satin Walnut*.—Grows in America. Is a new wood, light brown in colour, fairly strong and even in texture, but very liable to warp. Used for furniture, etc.

5. *Bow Saw*.—Is composed of four parts. The *frame*, made of beech. The *blade*, made of steel. *Handles*, made of boxwood with brass ends. *String*, made of whip cord. This saw illustrates the laws of compression and tension, which should be pointed out. It is used for sawing curves. The blade is nearly triangular in section, and the thinness at the top of blade and the wide set of teeth allows the saw to be turned in a small space. Point out the necessity of tightening up the string when the saw is in use, and loosening when finished with.

6. *Use of Bark*.—Explain that the barks of various trees are of some use. That of the oak for use in tanning, the cork tree provides cork from its bark, and other trees in various countries have bark useful in medicinal ways. Show that its primary use is to protect by a flexible covering the growing portion of the tree.

7. *Mortise Gauge*.—Compare with ordinary marking gauge, and show that this one is made of rosewood or ebony, has a steel screw, and a second and adjustable



spur. It is used for running a double parallel line along the grain.

8. *Felling*.—Explain that the woodman will choose winter for cutting down a tree, because there is least sap or moisture in it, and that there are several ways of felling. The old way, using the axe, then sawing with a long saw, and now experiments have been made with an electrically-heated wire. Explain the life of the lumbermen of America, where huge quantities of timber are felled and sent down the great rivers in the form of immense rafts.

9. *Mortise Chisel*.—Composed of two parts, and made in two kinds. One similar to a firmer chisel, but much stronger, and having the thickest part near the shoulder, which is much stronger, too, than in the firmer chisel. Compare the two, firmer and mortise, and point out the difference. The other kind is called a socket chisel, owing to the handle fitting in a socket. This chisel is mostly composed of iron with a steel face welded on, similar to the cutting-iron of the plane.

10. *Natural Seasoning*.—This is the name given to preparation of the newly-felled wood to make it fit for commercial purposes. The wood is usually cut into boards and stacked, so as to get plenty of ventilation, and in this way drying the sap which still remains in it. The effect of this drying is to shrink the wood, and often results in the wood splitting, but this is in a great way avoided when the timber is cut up in a proper manner.

11. *Trying and Smoothing Planes.*—The trying plane is much longer and heavier than the jackplane, and as its iron is set finer and it has a larger face a much truer surface can be made. The smoothing plane is much smaller than the jackplane, and has no handle, and is used for smoothing only, its short length renders it practically useless to get a large true surface, this is got by the larger plane, and the smoothing plane used finally to clean up. The Swedish pattern has a handle, but it is not generally used in England.

12. *Other ways of Seasoning.*—In these days of high rents a timber merchant cannot afford the expensive natural seasoning and wants in a few days what would take months in the natural way. So other methods have been found. One a little shorter than the natural way is to place the logs in a running stream, and gradually the sap is washed out, and afterwards the timber may be dried quickly, but the most common way is the hot-air system, in which the timber is placed in a large chamber heated by hot air, which soon dries up the wood; it is however more likely to split, but it is very much quicker and cheaper.

13. *Oilstone.*—Oilstones are of various kinds, the chief being Turkey, Washita, and Arkansas. Artificial stones made of emery. Explain the action the stone has on the steel, the pores having a cutting action similar to a file, and that only a lubricating oil must be used, such as sweet or olive oils. Explain that the oil keeps the pores open, and

that the stone should be kept covered and free from dust.

14. *Stacking Timber.*—Provide some model stacks of timber, and explain how, unless the timber is properly stacked with space between each board, it will not dry evenly, and probably get diseased.

15. *Grindstone.*—Point out the use of this stone, its coarse grit cutting away in a quicker manner than an oilstone, the large angle necessary for a cutting edge. The grit stone usually used comes from the Bilston quarries. Explain that to keep the grain open, water must be used, and also serves to keep the iron cool.

16. *Cutting-up Timber.*—Show by means of black-board sketches or diagrams how a log should be cut-up to the greatest advantage. This is done either by circular or band saw.

17. *Screws.*—Provide specimens of various kinds of screws, and an old screw without the gimlet point, and explain the difference and great superiority of the modern screw, and the fact that the screw is a kind of wedge. Prove this by an experiment—cut from paper a long wedge, wrap this round a cylinder and the thread of the screw will be seen.

18. *Principal Broad-leaf Trees.*—Oak, beech, ash, elm, sycamore, walnut, which all grow in England. Mahogany, walnut, basswood, which grow in America. Point out their characteristics.

19. *Scribing Gouge* is similar in construction to a chisel, but has curved blade, which is sharpened on the



SPECIMEN BLACKBOARD ILLUSTRATION.  
(Second Year Object Lessons Nos. 10 and 15.)

inner or concave side by means of a small piece of oilstone called a "slip."

20. *Cambium* is the name given to the outside ring of cells which form the active and growing portion of a tree, and have the power of increasing their number, forming during the year one of the rings of cells called annual rings. The exact way of their growth is unknown, but in some way they convert the sap into wood.

21. *Firmer Gouges* are indetical in shape to scribing gouges, differing only in the way they are ground, which is on the outside or convex side.

22. *Stem and Leaves*.—If a cross section of the stem or trunk of a tree be examined, it will be seen that it is composed of several parts. The bark, the sapwood, with the invisible cambium between, heartwood and pith. These parts all have their various uses: the pith exercises its functions in the early life of the tree before the cambium has begun to act; the leaves breath the air and extract from it carbonic acid gas, and returning oxygen; the carbonic acid gas is converted into starch, and helps to fill up the cells. They also exhale moisture.

23. *Wing Compasses* are made from iron, and composed of three parts, two legs movable and rivetted at the top, and sharpened to a point, and with a wing attached to one, which passes through a slot in the other, in which is fixed a screw to fix the legs at the required position.

24. *Principal Conifers*.—Northern pine, spruce fir, and larch, which grow in northern Europe. Weymouth pine, and Oregon pine, which grow in Canada and North America. Pitch pine and cedar, grow in southern part of North America. Cedar also grows in Asia Minor, India, and Australia.

25. *Glue*.—A gelatinous substance; is composed of the waste pieces of skin, hoofs and horns, and other offal. These substances are boiled, melted, re-boiled, and finally made into square cakes. There are three kinds: Scotch, strongest, a dark reddish brown colour. French, strong, transparent, thin, and an amber colour. Town, inferior in every way.

26. *Weymouth Pine*, comes from Canada, and is of straw colour when freshly cut, but tones down darker with exposure. The tree grows an immense size, logs as long as seventy feet have been imported. It has a very even texture, and is very soft, and about the best wood for manual instruction purposes is commonly called *Yellow Pine*.

27. *How to prepare and use Glue*.—The glue should be broken up and soaked in water for at least twelve hours, and then boiled steadily for about an hour. To use it, have it as hot as possible, and spread it lightly and quickly over the surfaces to be joined, then they should be rubbed together to exclude all superfluous glue, and kept under pressure till dry. Points to remember: The best glue is equal mixture of Scotch and French. Glue loses some of its strength every

time it is heated. The glue-pot should be kept clean, as dirty glue is useless. It should be thin, clean and hot.

28. *Cramp and Holdfast*.—The action of these two tools are similar, that of applying pressure by means of a screw. They should be carefully used, as too much pressure will often spoil the work, for they are capable of exerting great force.

29. *Teak* grows in India and Burmah, and is of a dark brown colour. It contains an oil which gives it the power of repelling the attack of the white ants of India. The tree is of immense size, and bears very large leaves. It is used in shipbuilding, shop and laboratory fittings, etc.

30. *Gimlets*.—Composed of two parts, a steel shank and wooden handle. There are two kinds, one with a groove along the shank called shell gimlets, and the other with a twist running up the shank, these are called twist gimlets, and are the better kind. The action of the groove and hollow twist is the same, to allow the core to escape. A large kind of gimlet is called an auger.

31. *Medullary Rays*.—This is the name given to the rows of cells which run from the middle to the outside of the wood. Their use is to bind the rings together, and so give strength to the timber. They are often short in length, sometimes only joining one or two rings, but they are always at right angles to the annual rings.

32. *Saws*.—Illustrate on the board the kinds of teeth in a tenon saw, hand saw and rip saw. Showing the different positions of the 60 deg. angle, and show also the meaning of the words “pitch,” “sit,” and “gullet.”

33. *Sycamore* grows in England and Europe, is fairly hard and white in colour, but is liable to warp. It is used for cabinet-making and marquetry.

### Object Lessons. Third Year.

1. *Brace and Bits*.—*The brace* is composed of a steel crank, with a head and handle made of lignum vitæ, and fitted with adjustable jaws. *The bits*, made of steel, hardened and tempered, are of various kinds, the most common is the centre bit, used generally to bore holes from  $\frac{1}{4}$  in. to  $1\frac{1}{2}$  in. The shell, spoon, or pin bit, hollowed like a gouge, are used in boring through thick pieces of wood. The auger or twist bit, bores a true hole, easiest and quickest. The wood and metal countersink bit, enlarges the top to a conical shape for screw head, etc. The turnscrew bit, used for driving screws quickly. The rimer bit, enlarges existing holes.

2. *Beech*.—Grows both in England, Europe, Asia, America, and Australia, and is of a light brown colour. It has a straight grain, a very distinct medullary ray, and is of a very even texture. The timber is largely used by tool makers, and also in making chairs and cabinet work.



3. *Steel* is really iron improved in quality by the addition of carbon. This addition makes it stronger, and finer in grain. Steel has the important quality of being tempered on heating and then plunged into water. It may be considered the universal metal, used for needles and steel girders, screws and ships of war. Show the effect caused by heating steel to a red heat, and cooling first in water, and then slowly. A broken bow-saw blade will be found very useful for this experiment.

4. *Oak*.—There are two kinds, ordinary and wainscot; the latter comes from Holland and Riga, but oak grows in England, nearly all over Europe, and North America. Owing to its rich brown colour and the straight grain, that beautiful effect gained by cutting diagonally across the medullary rays, the timber is highly valued. It is a very strong and heavy wood, but of an uneven texture, and it contains a corrosive acid, which affects metal fastenings. The tree bears gall nuts, which are formed by the gall fly. The bark containing gallic acid is used for tanning. The timber is universally used.

5. *Sharpening Gouges*.—These tools are difficult to sharpen, the scribing gouges must be sharpened by means of an oilstone slip. While firmer gouges must be placed on the stone and held at the cutting angle, and rolled from side to side while moving up and down the stone.

6. *Ash*, grows in England, Asia, and America. It

is of a whitish brown colour, and is usually uneven in grain. It is noted for its flexibility and strength, and used by coachbuilders, and for building tramcars and railway carriages, in fact any position where strength combined with flexibility is required.

7. *Sharpening Saws*.—This is an operation that requires a lot of practice and skill. The saw is first set, in the case of the saws of the manual training room, by means of a thin hammer which knocks down the teeth to a certain distance. Then a triangular file is used to give each tooth a sharp point and edge.

8. *Mahogany*.—There are two kinds, Spanish and Honduras. *The Spanish variety*, which is the better kind, and contains chalk-like marks, grows in the West Indian Islands, and originally came from Cuba. It was brought to Europe by the Spaniards, and named after them. The Honduras variety grows in Central America, and is not so strong or durable. Both timbers have an even texture and a rich red colour, and on this account are used principally for ornamental work.

9. *Rebate Planes* are made in several ways, usually a thin piece of beech with the inclined iron placed in at right angles to the side or on the "skew." They are used where the whole width of the cutting edge is required, such as a rebate, etc.

10. *Borwood* grows in England, inferior varieties come from Asia. An even-grained wood of a yellow colour, possessing immense strength and great weight.

It is used by tool-makers, instrument makers, and for turning.

11. *The Bench*.—Sketches should be made of the various joints used in the construction of the bench. The timber named, and the use and construction of the vice and stop, etc., explained.

12. *White Deal* grows in Northern Europe, and has a white silvery appearance when planed. It is fairly strong, but has plenty of knots. It comes from the spruce fir, and the timber is used in building, and for purposes where a wood of a clean white appearance is needed.

13. *Roots and their Use*.—Roots play an active part in the life of the tree. They form a foundation to the trunk, and keep the tree firmly attached to the ground, and more important still, they absorb from the soil moisture and various substances necessary to the growth of the tree.

14. *Larch* grows in England, in Northern Europe and Switzerland. It is of a brown colour and even texture. It is a strong timber, and used where a durable wood is required. The tree is one of the most graceful of the conifers.

15. *Bevels* are akin to the square, and are of two kinds, fixed and movable. The movable bevel is composed of three parts, a *wooden stock*, either ebony or rosewood, bound at each end with brass, a *steel blade*, having a long slot in it, and a *screw* fitting in the end of the stock, and through the slot in the blade.



SPECIMEN BLACKBOARD ILLUSTRATION.  
(Third Year Object Lesson No. 12.)

The mitre bevel (45 deg.) is the commonest fixed bevel.

16. *Pitch Pine* grows in the southern portion of the United States. It is of a rich brown colour, with red markings. The texture is very uneven, but its grain has a good appearance when "finished." It is noted for the amount of resin it contains. It is used where great strength is required, and for ornamental cabinet work, church and school furniture.

17. *Elm* grows in England, Europe, and some parts of America, and is of a reddish-brown colour. Its texture is fairly even, but the grain is very twisted. It is tough and fairly flexible, the sapwood is as durable as the heartwood, and is noted for its durability under water. Used by wheelwrights, coach, and boat-builders.

18. *Exogen* is the botanical name given to that great group of trees, in which is included conifers and broad-leaf trees. The word is derived from Greek, and means an outside grower. These trees increase their bulk by continually forming new layers of wood outside the old layers.

19. *Cedar* grows in Asia Minor, the southern portion of North America, India, and Australia. It is very even in texture and soft, is durable, but not very strong. It has a reddish brown colour, and its sapwood is white. The timber has a pleasant odour, and is used in cabinet-making, and for covering the lead of pencils.

20. *Endogen*, or an inward grower is the botanical

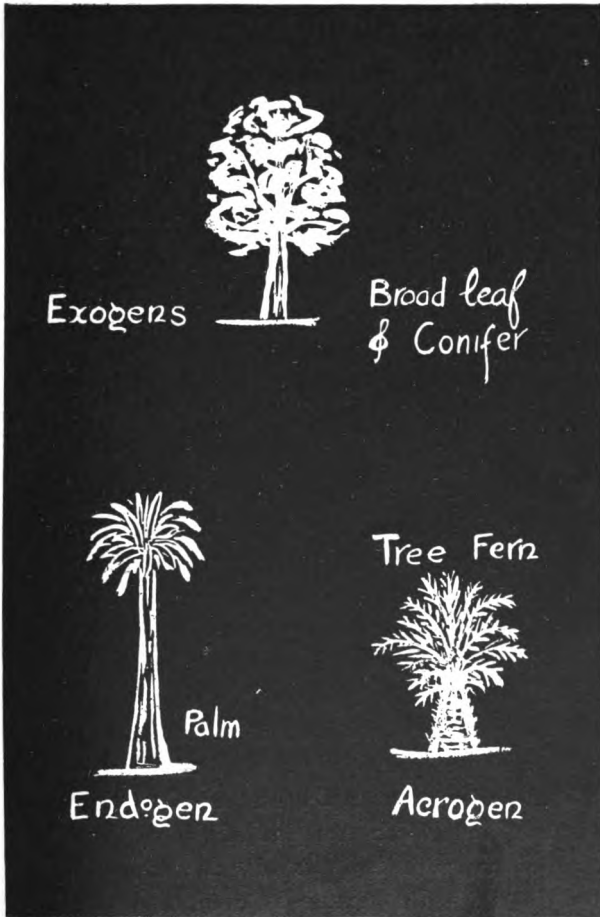

SPECIMEN BLACKBOARD ILLUSTRATION.  
(Third Year Object Lessons Nos. 18, 20, and 22.)

name given to that class of tree, such as palms, which grow inwardly. They are not suitable for timber.

21. *Kauri Pine* grows in New Zealand, and is of a silky light brown colour when planed. It is even in texture, and has a straight grain. The tree grows to an immense height, and there exudes from the tree a gum which is of great value, and used in making high-class varnishes. It is used for all purposes where a straight-grained strong and flexible wood is required.

22. *Acrogen* is another botanical name, meaning a summit growth represented by the tree palms; these trees send out their branches from the summit. They are not fit for timber.

23. *Birch*.—The tree grows in England and Europe, and is lightish-brown in colour; it is even in texture, and fairly easy to work, but its grain is rather uneven. The timber is used in cabinet-making, and the tree, with its fine leaves, has a very graceful appearance.

24. *Greenheart* grows in parts of South America. It is light brown in colour, with the sapwood green. It is even in texture, and is one of the strongest timbers known, and used principally in shipbuilding.

25. *The Yew* grows in England and Central Europe, and Asia, and North America. It is of a reddish brown colour, with light and dark veinings, the sapwood is white, the texture is even, and the grain straight. It was grown in churchyards, owing to its great use in the days of bows. It is a very strong

and heavy timber, and noted for its durability under water.

26. *Cypress* grows in Asia, but may be seen growing in some parts of England. It is of a yellow colour, even in texture, and has a resinous smell. It is strong and durable, but used principally in the form of veneer, owing to its scarcity.

27. *The Evolution of Tools.*—Explain the gradual introduction of metal in the manufacture of tools, how the pre-historic man used sharp flints for his cutting instruments, how in later ages bronze was discovered and worked, and then iron, and now steel.

28. *Lignum Vitæ* grows in West Indies and Central America, of a dark green colour, with white sapwood. It has an even texture and twisted grain, which is very difficult to split. It is never imported in very large pieces, and is used where great strength is required cogs of wheels, and the packing of propellor shafts are made from it.

29. *Ebony* grows in India and North Africa, is black in colour, with occasionally light streaks in it. It is very hard and strong, and heavy, and is only used in small pieces.

30. *Defects and Diseases of Timber.*—Timber is liable to a good many defects and several diseases. Show illustration of heart, star and cup stakes, and explain the action of dry and wet rot in destroying the fibres and rendering the wood useless, and how necessary it is for timber to be exposed to the air.



31. *Forestry* is the art of cultivating forests, and in these days when timber is of considerable value, every large estate keep a staff of foresters whose duty it is to time the felling of trees which have arrived at maturity, and lay out and tend new plantations.

32. *Hornbeam* grows in England and Europe, the timber is similar to ash, but not as strong. It is used for agricultural implement making.

33. *Tulipwood* grows in Central America and Australia. is of a yellowish colour, and has an even texture. It is used for turning and ornamental joinery.

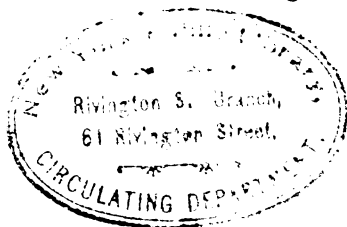

## TOOLS FOR A CLASS OF TWENTY PUPILS.

*For each boy:—*

Jack Plane. Tenon Saw.  
4 Chisels, 1,  $\frac{3}{4}$ ,  $\frac{1}{2}$ ,  $\frac{1}{4}$ .  
Mallet. Hammer.  
Iron Rule, 2 ft. Try Square.  
Marking Gauge.  
Scribing Knife.

*One between two:—*

Smoothing Plane. Screwdriver.  
Handsaw. Bevel.  
Bow Saw, 10 in. Wing Compasses.  
Inside and Outside Spokeshave.  
Mortise Gauge.

*General:—*

20 Assorted Bradawls.	3 Trying Planes.
4 Oilstones.	12 Small Screw Cramps.
2 Slips.	6 Punches.
6 Braces.	2 Oilcans.
6 Sets of Assorted Bits (11, from $\frac{1}{4}$ to $1\frac{1}{2}$ ).	6 Pincers.
6 Wood Countersink Bits.	12 Assorted Scribing and Firmer Gouges.
12 Spoon Bits.	2 Rebate Planes.
12 Assorted Files.	Gluepot.
	Grindstone.

