

Knotting Matters

Newsletter of the



INTERNATIONAL
GUILD OF KNOT TYERS

"KNOTTING MATTERS"

THE QUARTERLY NEWSLETTER OF THE
INTERNATIONAL GUILD OF KNOT TYERS

President: GEOFFREY BUDWORTH

Issue No. 23
April (Spring) 1988

Guild annual subscription rates
renewable 1st. January:-
Juniors (under 16 years)£2.50p;
Seniors £10.00p;
Families £15.00p;
Corporateby arrangement.

Hon. Secretary
Frank HARRIS
14 Games House,
Springfield Grove,
Charlton,
London SE7 7TN
England.
Tel: 01-858 6728

Hon. Editor
Geoffrey BUDWORTH,
7 Hazel Shaw,
Tonbridge,
Kent TN10 3QE,
England.
Tel: 0732 360384 (home)
01-760 5427 (office)

Editorial

When electricity supplanted gas to light private dwellings, most of the electrical goods around now were already being marketed then. From refrigerators to bed-warmers, razors, sunray lamps, and odd vibrating appliances, there is nothing new, only the designs have been modernised. The manufacturers of this mass-merchandise were ... the electricity generating companies! They recognised a product was only profitable when there was adequate demand, so they made and sold gadgets that used electricity.

My friend Ron is unique, having built his own swimming pool to run as a business. A few years after he started up, a major municipal leisure complex was created a mile or so down the road. I feared - and so did he - that it might ruin him. No, indeed. Between them they generate more work than either can handle. Demand outstrips supply. (This is why restaurants, shoe shops, antique dealers, etc., cluster in certain streets where all will benefit from the trade which is attracted there.)

What thought and effort, I wonder, do the rope and cordage suppliers put into ensuring they sell their products? My classified 'Yellow Pages' telephone directory lists nothing between "Roofing Repairs" and "Rosettes, Cups & Trophies". Nobody apparently wants "Rope, Twine & Cord"; yet I work in the U.K.'s 10th. largest town, which is also London's 5th. largest and most populous borough with 319,000 residents and a massive workforce.

We knot tyers and ropeworkers consume a fair amount of cordage but cannot locate what we need to buy other than by random (and often fruitless) shopping expeditions. I often forego ropework when I cannot locate the right stuff, nor can I point others towards sources of supply since the few good stockists I knew have all disappeared, complaining no doubt about lack of customers.

The ropemakers, their wholesalers and retailers, must learn that we exist. They must be persuaded that it makes commercial sense to encourage us and to have us multiply. More of us is good for them: more of them is better for us and them. I look forward to the day when they ask us what we need; give away free tools and samples of their wares; sponsor displays and demonstrations of ropeworking; defray the I.G.K.T.'s printing costs and publications; not out of charity but because there is profit in looking after us.

More Mats by M. "King" de KONING
of The Netherlands

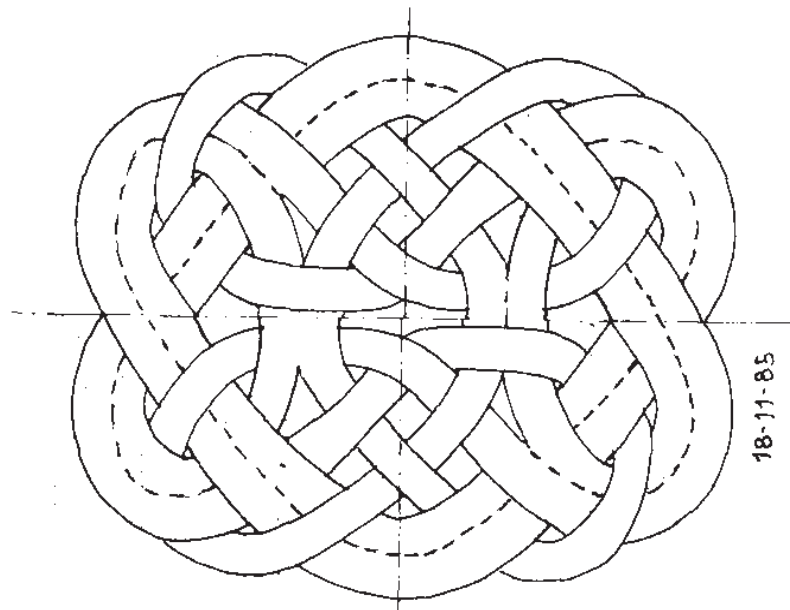
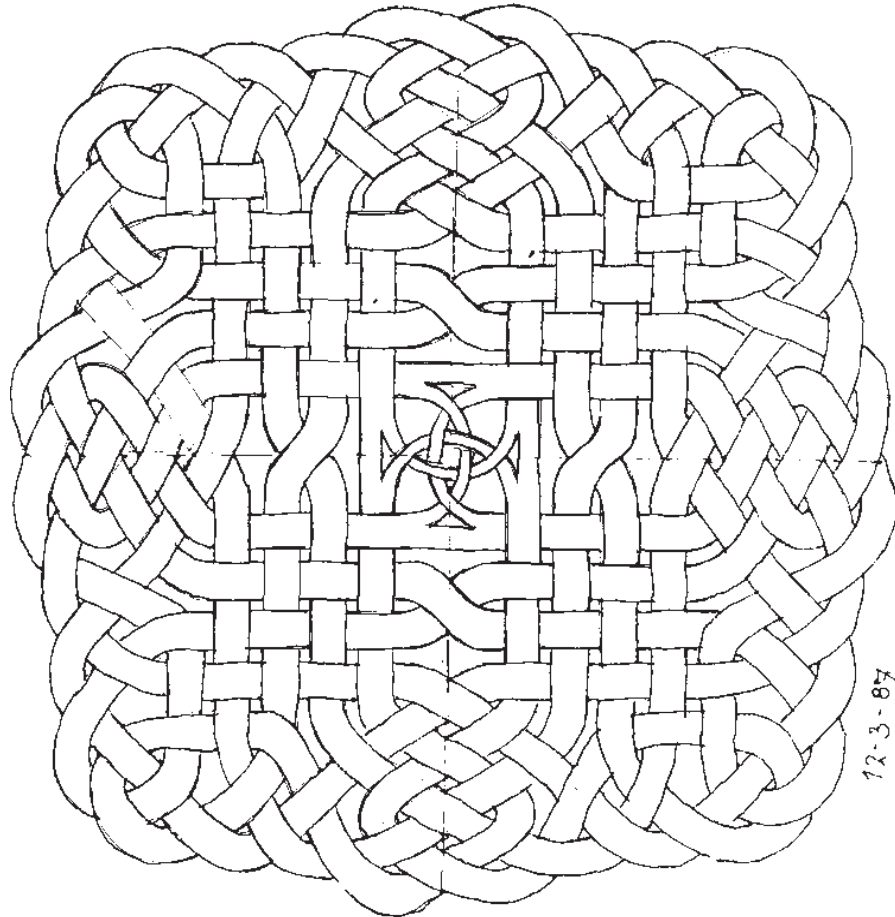

Bends & Loops

by Harry ASHER
illustrated by Graham HUDSON

The Broach¹ (Fig's 1 , 2 & 3)

This bend is tied as shown in Fig. 1(a), (b) & (c). The appearance may be improved by adding the further tuck shown in Fig. 1(d) & (e). To achieve a more satisfying form of symmetry the running and standing parts of one half of the knot may be interchanged by lengthening the one and shortening the other (Fig. 1(f)), thus bringing the two short parts opposite each other.

Fig. 2 shows a different way of adding the extra tuck; now each running end lies next to the standing part of the opposite cord. As previously explained (*2) this is the perfect setting for converting the bend into a loop.

To do this, the first step is to learn a new method of tying the knot. Start with it already tied by the old method, then loosen it and with one hand hold, say, the dark half firmly so as to preserve its shape, and with the other hand remove one or two tucks from the opposite half; then replace the tucks before they fade from memory. Proceed to take more tucks out until you have learnt to reform the knot after the two halves have been taken completely apart. Next learn to make the simple shape of the dark half, which is simply a Figure-of-Eight shape (NOT knot), which can be tied extremely swiftly 'in the bight'. Put back the memorized tucks to produce the Loop.

To tie the loop (Fig. 3) first make the shape of the one half of the knot at the required distance from the end, and then take the end and thread it all the way through this half knot, following the same path as you did for the bend. It does not take as long to tie as its complex shape might suggest.

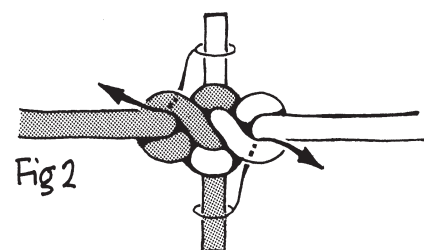
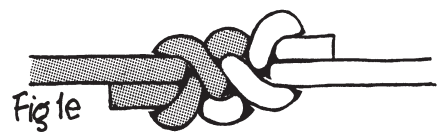
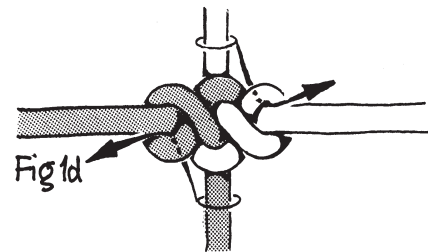
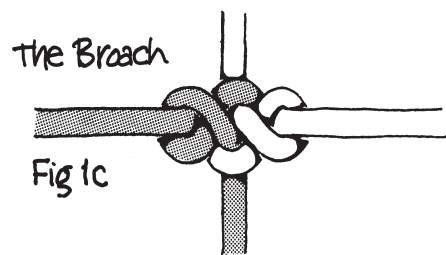
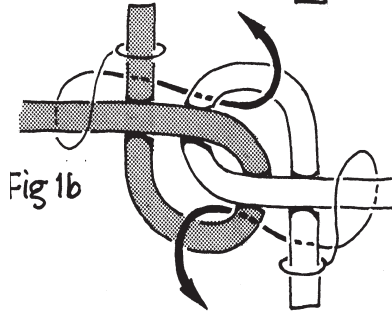
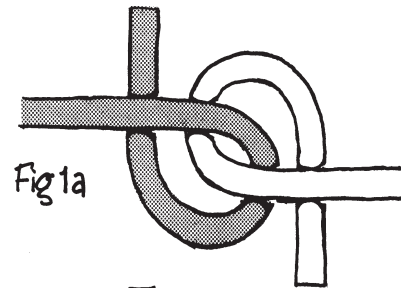

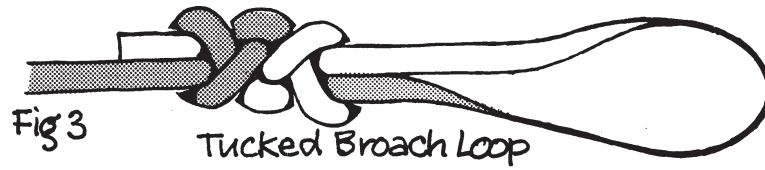

Knotsmen with a purely practical approach may prefer the simpler loop of Fig. 4(a), (b) & (c). It was derived from K.M. No. 8, page 6, and that article's Fig. 8.

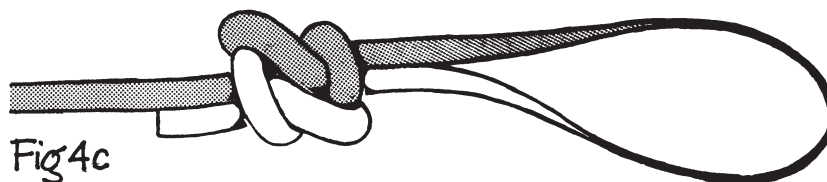
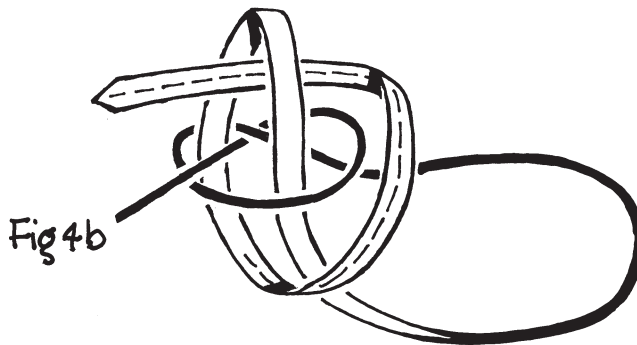

The Enhanced Bowline (Fig. 5)

Start as for the normal Bowline, but, when the rabbit has come up through the hole and has gone round the tree once, let it scamper the whole way round a second time before returning down the burrow. The knot takes a split second longer to tie...but I claim that the slight danger of a capsize is removed and appearance is improved.

(Peter van de Griend has pointed out from the Faroes that the Enhanced Bowline is in Graumont & Hensells 'Encyclopedia', plate 11, No. 195. This G. & H. knot is pulled up quite differently, however; it does not look the same and does not lend itself to the subsequent development as an enhanced Sheet Bend (see Fig. 7 below).

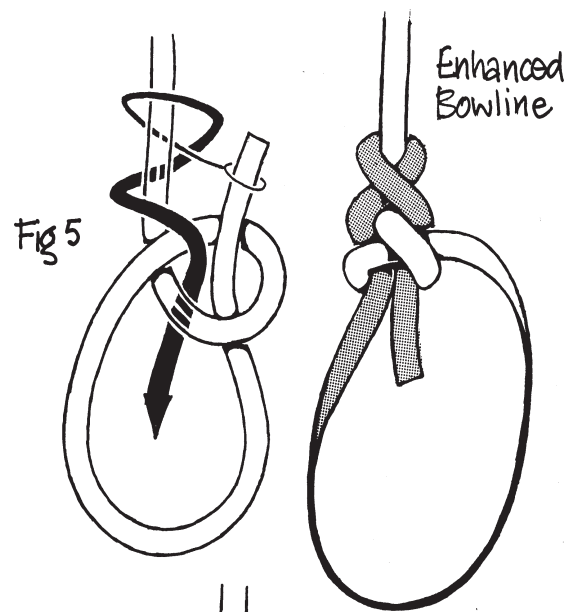

Belt & Braces (Fig. 6)
The same modification can be applied to the Double Bowline.

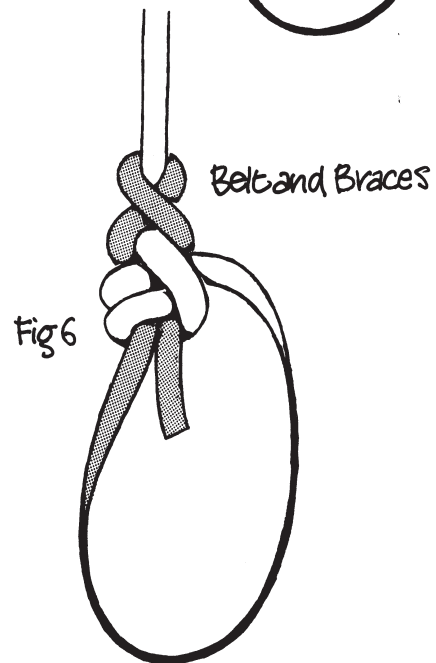

Enhanced Sheet Bend (Fig. 7)
The same method applied to the Sheet Bend yields an ugly knot with the running end sticking out awkwardly; but an extra tuck converts it into a graceful symmetrical knot: Vice Versa(*3)

Footnotes

- *1 'A New System of Knotting'
by Harry Asher,
Vol. I, page 12.
- *2 . 'A New System of Knotting'
by Harry Asher,
Vol. II, page 6.
- *3 . 'A New System of Knotting'
by Harry Asher,
Vol. 1, page 4.

(These I.G.K.T. publications are available from Mrs. Ivy Blandford in the Guild's shop,)

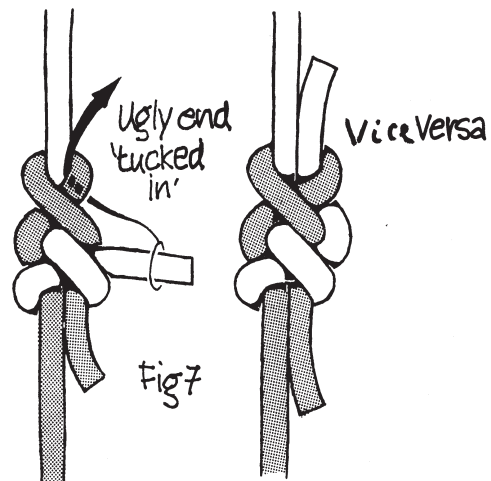

FOLKLORE OF DUNBEATH

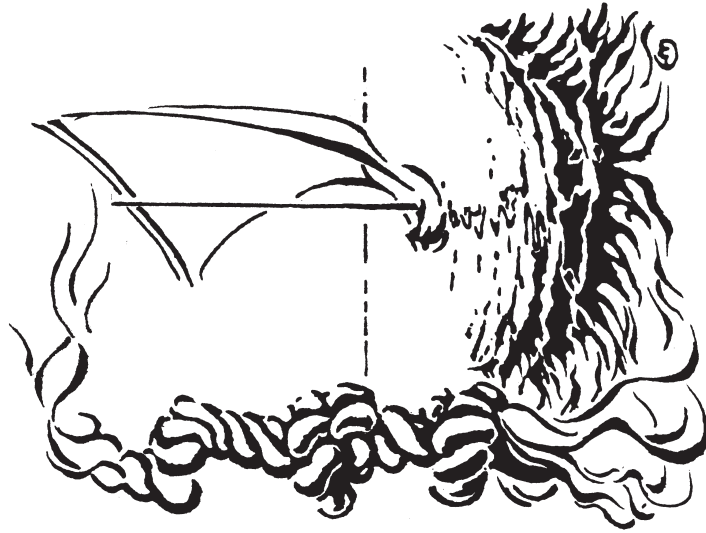

by

HELEN LINDSAY

Illustrations by **Ewan Morrison**

Preface

From Ray Stanton Avery, Founder Chairman, The Dunbeath Preservation Trust.

It is very appropriate that this book should be published in the same year that the Dunbeath Preservation Trust comes into being. The thorough research having been carried out through the eyes and ears of a fifteen year old schoolgirl, Helen Lindsay, from stories related to her by an older generation covering the folklore of a bygone era, really does encompass what I consider to be a most important ingredient of the Trust namely, an element of the life of a whole community from its distant past to the present day.

In her own introduction to this lovely treatise, Helen expresses regret at the demise of ceilidhing, which enabled so many tales of our past to be retold in friendly company. Maybe there are several youngsters around us with Helen's outlook who will help revitalise this art. Let's hope so.

To Ewan Morrison I extend my congratulations and admiration for producing, so sensitively, the artwork associated with many of Helen's stories. I am sure that we in the Trust will relish having been the first to publish his work, and I have little doubt that he will find great success in his future career. I have much pleasure in linking Helen and Ewan with the name of the Dunbeath Preservation Trust. Our joint aims are so similar that I feel sure that this initial publication must be the forerunner to many more covering this wonderful place, Dunbeath.

R. Stanton Avery

Dunbeath Castle,
Caithness, Scotland.
December, 1985

(Guild members who enjoy the following tale can buy Helen Lindsay's book and so benefit the Dunbeath Preservation Trust.)

The Three Knots

One year about the middle of the 19th Century during the herring fishing season, a Lybster boat went to Portmahomack to collect a load of staves for making barrels.

When they set sail the weather conditions were perfect and continued to be like this throughout the voyage. When they reached the harbour at Portmahomack, the crew left the boat and went ashore to renew old friendships and so the evening passed pleasantly.

Next day they loaded the cargo onto the ship and prepared her for the next day when they thought they would leave for home. That night the wind dropped and all was still. It was obvious that this weather would prevail for some time. The crew were annoyed because during the herring season they needed to be at home to catch the fish and also the coopers needed the staves to make barrels.

Jamie, the skipper of the boat, was talking to a friend from Portmahomack and as they discussed the affair he said that he hoped the wind would rise by the next night. His friend told him not to bother waiting until the next night but to go to a witch who could help them get off in the morning. In return for her services he was to give her a half-a-crown. Jamie went straight to the witch's cottage. She knew already, by some means, that he was a fisherman. He told her his grievance and gave her half-a-crown. She gave him a piece of thread in which was tied three knots. When they were setting out he was to untie the first knot and a breeze would help them on their way. Once they had gone a fair distance he was to untie the second knot which would make, the breeze stronger and thus enable them to return home more quickly. He was strictly forbidden to open the third knot.

Next day, they got ready to go home. The boat was ready to sail and Jamie untied the first knot. A small breeze blew up from the south-west and filled the sails. They were on their way! Jamie undid the second knot when they were about half-way home and the breeze grew stronger, carrying the boat speedily towards its port.

They came very near to Lybster harbour when one of the crew who believed that nothing could harm them now, persuaded Jamie to untie the third knot. As soon as he undid it the wind changed direction, assumed gale force, and blew the boat back out to open sea. Jamie and his crew were obliged to take shelter in Portmahomack harbour which they had left about ten hours before.

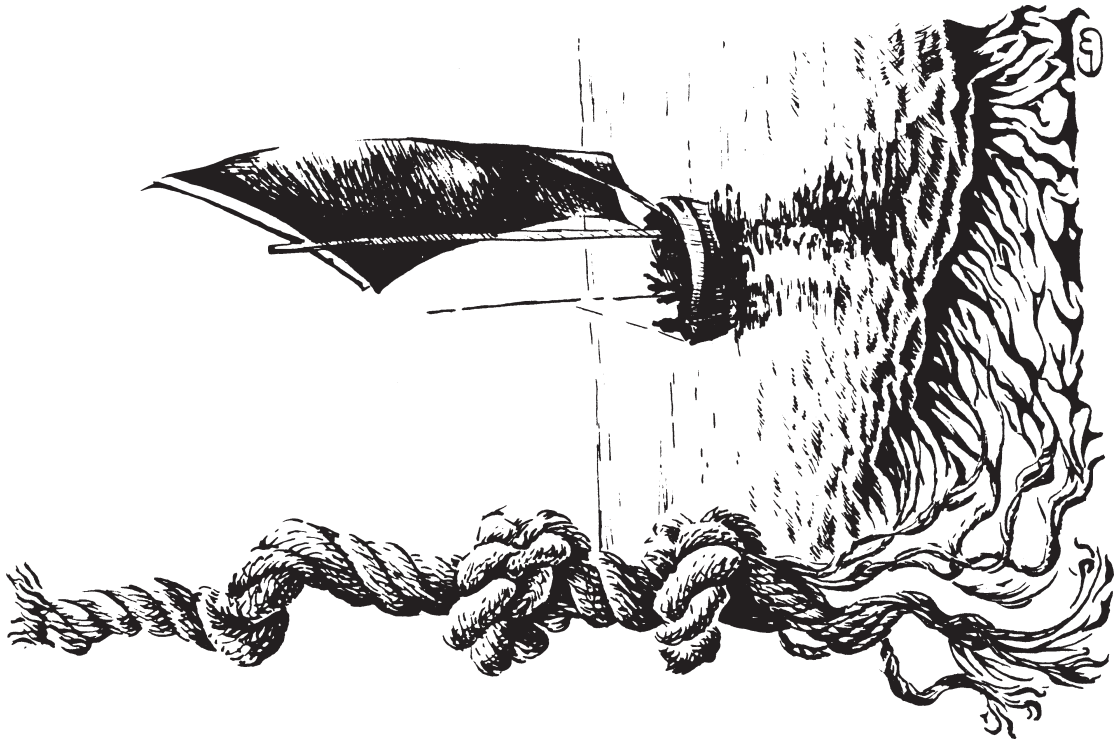

Knots – topological or ergonomical

by Desmond MANDEVILLE

An extract from 'The Mathematical Theory of Big Game Hunting' (P'etard, 1938),
..... quoted in 'A Random Walk in Science'
(R.L. Weber, 1973):-
"For the sake of simplicity we shall
confine our attention to Lions whose habitat is
the Sahara Desert
..... Method 7 (topological) We transport
the desert into four-space. it is then possible to
carry out such a deformation that the lion can be
returned to three-space in a knotted condition. He
is then helpless."

1. The mathematical theory of knots has a limited interest for knot tyers. Knots find their way into mathematical textbooks already tied, and the process of tying is not discussed. Any knot that can be tied can also untie, and in the hands of a topologist it certainly will. Indeed, a knot with free ends is of little interest to mathematicians, so readily is it convertible to (or, as they might say, "homoeomorphic with") one or more straight pieces of cord!
2. The nearest we come in practice to topological knots is with Turks' Heads. If we suppose the concealed ends of a Turk's Head to have been spliced together after it was completed, it will approximate to a topological knot, the Torus Knot. Torus Knots, to the mathematician, constitute the simplest class of knots, apart from the so-called "Trivial Knot" (which is just an unknotted loop). They lend themselves to a straightforward algebraic description, neatly reflecting the 'leads' and 'bights' used in describing Turks' Heads. A very great deal of work has been done on the enumeration of these and other closed-loop knots having a given number of crossing points (when depicted on paper).
3. Two systems of enumeration are in current use, a geometric system and a cyclic one. Much effort is needed to eliminate equivalents, i.e. knots that convert into others on the list, of the same - or even a different - number of crossings, by means of one or more "flyping" (or capsizing) operations. Flyping may in fact be executed numerically. With the aid of a computer the task has been completed exhaustively for knots of up to 12 crossings. Knots which are mirror images of each other are, for this purpose, regarded as equivalent - even if they will not flype.
4. Thus pruned down, there are only one topological knot with 3 crossings (the Clover Leaf), one with 4 (the Figure of Eight) and two with 5 crossings. At the other end of the scale so far studied there are found to be 1,288 alternating (over-&-under) and 888 non-alternating knots with 12 crossings. Each of these is a single, non-composite, knot tied in a continuous closed loop of cord. A 19th. century mathematician, Tait, coined the expression "Beknottedness" for the degree of high complexity involved.

5. Let us now reduce one of these "closed loop" topological knots to a knot as knot-tyers understand it best, a knot with two free ends. We do this by cutting the loop, once, and pulling the cut ends apart without allowing them to tuck or untuck on the way. The knot now no doubt assumes a different shape - even has a different number of crossing points (it will flype, in fact) - before drawing up finally into one of several possible 'equivalent' configurations. The closed-loop knot of 4 crossings, for instance, might yield any one of 4 free-end knots (2 Figure-of-Eights and 2 Pretzels), all of them well-known and stable structures.



6. Cutting the loop thus, and pulling the ends apart without untucking, does not in itself break faith with our topologist friends who are equally at home with a pair of ends stretching out to infinity in either direction so that tucking/untucking cannot occur. As soon, however, as we describe a final knot as "stable" we begin to be out on our own. For stability introduces notions of tension, flexibility and friction, met with in all real cords of measurable girth... subjects that are NOT on any topologist syllabus! The distinction between 'topological' and 'ergonomical' knots is indeed one that finally cannot be glossed over.

7. Before leaving knots on a single cord, a mathematician might agree that the operation of cutting the cord and pulling the free ends apart (to infinity if need be) greatly enlarges the field for study and enumeration. An alternating knot of 12 crossings, for instance, can be cut into 24 distinct ways, at each crossing either the lower or the upper cord may be cut. 'Each such cut will yield, as the ends pull apart, its own family of 'equivalent' knots. No two of these families are necessarily alike. The scope for computer analysis is surely almost endless.

8. The families of knots derived from a single knot of 12 crossings by cutting the cord once, in various positions, remain related all the same. This may be demonstrated by a series of linked tuck/untuck operations undertaken with the ends, not more than 12 of which will be required. In effect, what is done is to work the cut which produces 'Family A' through the crossings of the original knot by the shortest route, till it occupies the position of the cut which produces 'Family B'. Knot-tyers are well acquainted with this procedure. It is a special case of the tucking ramble (T-ramble or 'Tramble') method developed recently for the inter-conversion of the common Bends without untying them. The conclusion might therefore be stated briefly thus:- all free-end knots derived from the one closed-loop knot by cutting once will 'Tramble'.

9. Coming next to Bends (knots uniting free ends of cord), what will startle - or even shock - the ordinary knot-tyer is a candid admission that the Reef and Granny Knots cannot be distinguished from one another, mathematically ... even after more than 100 pages of theorems and analysis ... without recourse to "still more advanced" methods. Yet the difference is blindingly obvious to the practised knot-tyer! Even in the form in which topologists insist on studying them, with standing ends spliced together (working ends likewise) so that the knots are tied in a continuous closed loop of cord, the distinction remains. Both then are composite knots consisting in 2 Overhands (or Clover Leafs)

tied along a single closed loop; but in one the Overhands are likehanded and in the other unlike, putting the 2 knots seemingly into quite separate symmetry classes.

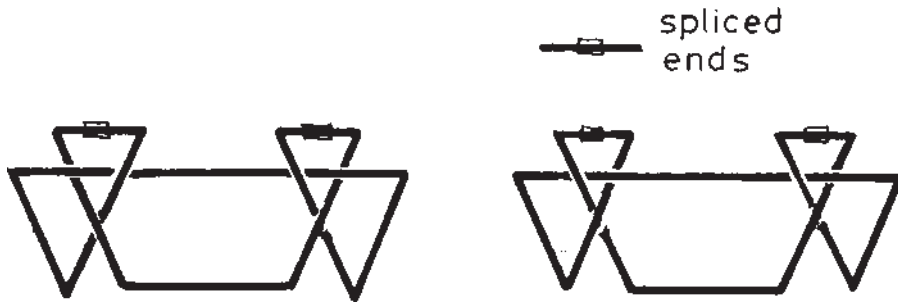

10. One may well feel puzzled as to how so abstruse and wayward a line of study can possibly lead to conclusions of practical importance. Guild members should resist jumping to hasty conclusions here. Several of us have thought long and hard about the classification of knots and bends and there is as yet little to show for it by way of results that command general agreement. Possibly the mathematicians' systems of enumerating knots (para. 3), their concept of equivalent knots (para. 5), and the relations between families derived from a single knot by cutting (para. 7) are subjects that will repay painstaking practical study in this connection.

D. G. M.
25 March 1987

References

- (a) Dowker & Thistlethwaite (1982)
- (b) Crowell & Fox (1963), page 131; but see also an article by Lee Neuwirth ('Scientific American', June 1979) which is more accessible to the ordinary reader.

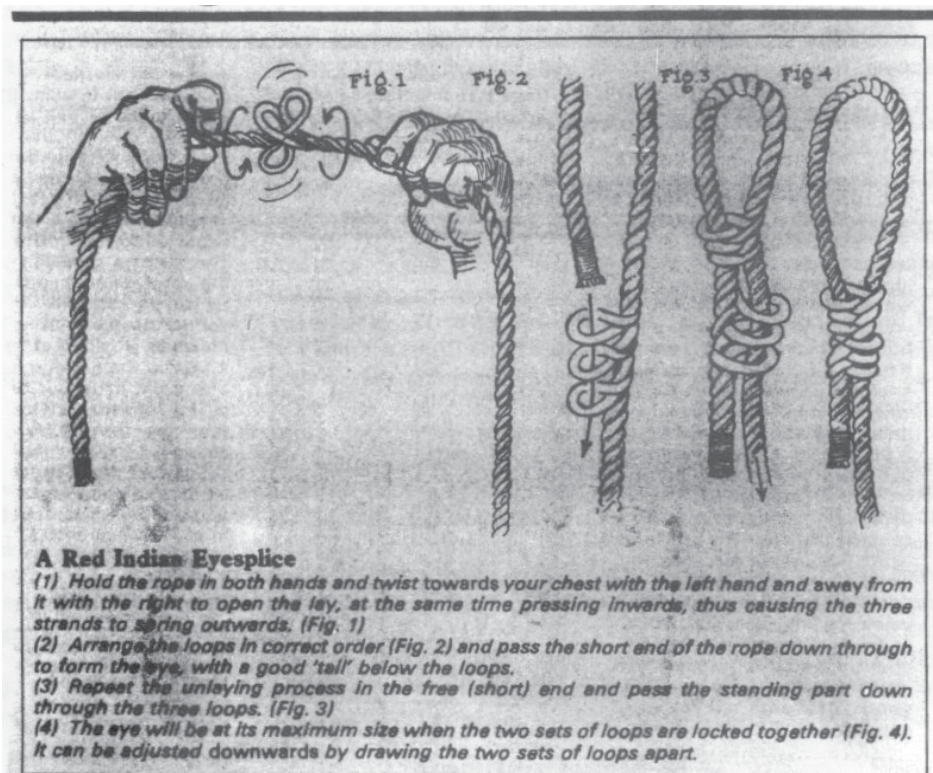

From 'SCOUTING' magazine
(date - unknown)

Salmagundi

cooked up by the Editor
to dispose of some leftovers

TOP ROPE I collect toy spinning tops (mostly antique curios) and have hundreds of these playthings. Many are started by wrapping rope or cord around them. The Japanese are very clever at this and one top rope I handled recently was quite ingeniously made - 3' long, 2-strands, and tapered from 0.8 cm at the working (hand) end down to 0.5 cm at the standing (top) end.

GIVE US A TUNE Ted UPTON of Watton-at-Stone wonders what the I.G.K.T.'s signature tune might be; certainly not the song of the sheet music he sent me a while back entitled "Hangknot, Slipknot", words and music by Woody Guthrie, copyright 1963, Ludlow Music Inc., New York, U.S.A. Music-making knot-tyers may care to track it down and let us have a rendition sometime.

GIVE US A TWIRL For the limited bit of cowboy rope twirling I can do, I do not have a proper lariat with a hard-eyed honda (or even a soft one). I just knot a length of suitable braided stuff to make the loop. The sliding knot I have settled on (see drawing below) is easily adjusted and is so arranged that it encourages the loop to open. Have that on me.

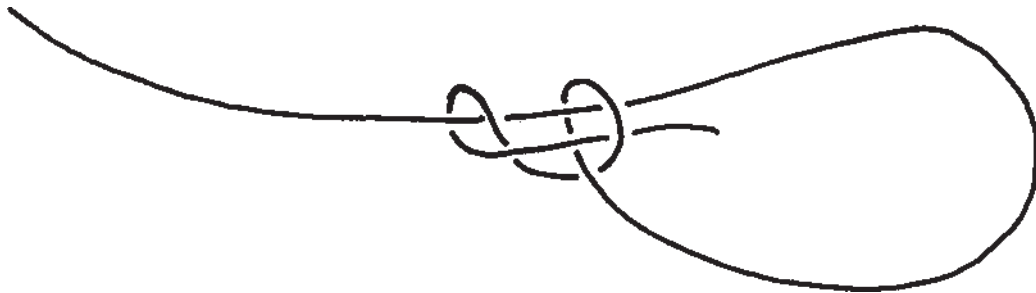

AUTOMATION We all know that machines make nets but now Brian LAMB draws our attention to a machine that ties knots. Massey Ferguson Manufacturing Ltd. make farm machinery and their crop balers are equipped with a knotting mechanism which ties all types of sisal or plastic twine. A twine box holds 4-6 balls (depending upon the model), enough for up to 1,800 bales. The latest knotters have less moving parts for increased reliability, giving tighter and better looking bales tied with stronger knots, and less wastage (more bales per ball). They only tie 2 parallel ends together in an Overhand Knot, and then neatly cut them off, but where could it not lead? Pass me my Matthew-Walker-tying patent pliers!

PHOTOCOPYING S.E. ANDERSSON and I were chatting-on the 'phone one day (me in London and him in Stockholm) and the topic cropped up of how to teach people knots on paper when you cannot draw like Stuart GRAINGER. S-E's solution is to fix braided yellow polyester about 2 mm dia. onto a photocopy machine with double-sided adhesive tape. The results (see next page) are then put in the typewriter for captions.



PILLE REPMAKAR'N

Råseglarhuset · Skeppsholmen

S 111 49 Stockholm



Läsegelstek

Smugglarsstek

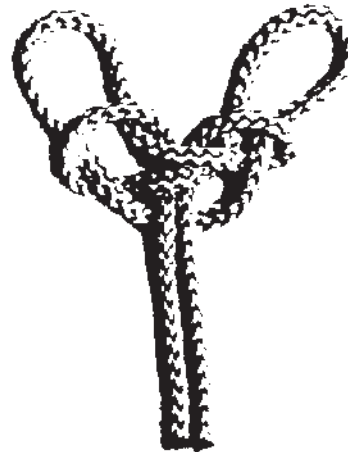
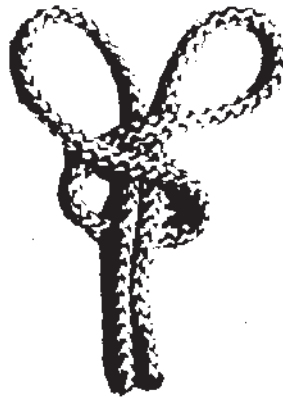
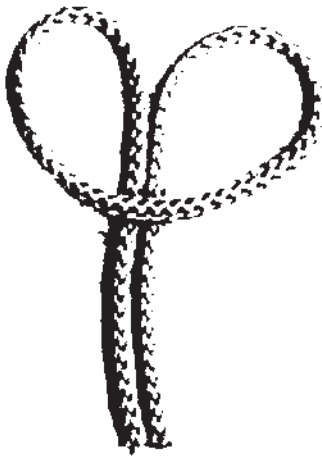

Swansk Pålstek

FINGER BRAIDS Erica JOHNSON came back from Israel last year with an attractive braid of many coloured yarns sold her by an Arab there. He suggested she could use it as a tie-belt, although it might actually be a sling of the sort used by Bedouin women to carry bundles' suspended from bindings around their foreheads. Incidentally, the braids are just right as nice bookmarks. Erica worked out for herself how to make them and, judging from the super specimen I saw, it is the technique illustrated in Graumont & Wenstrom's 'Square Knot Handicraft Guide' (pub. Cornell Maritime Press, 1949) for wampum belt designs. Now, confound us all, Joanna BODGER has been seen at Guild meetings tying 'Friendship Bracelets' in French D.M.C. threads as trendy fashion accessories for young people to give one another. This up-to-the-minute fashion item ("... sweeping the country," accordingly to D.M.G.'s, advertising blurb) and the Israeli braid are similar products. Is there nothing new in knotting?

ROPE TACKLES IN PRACTICE

By Charles Warner,
New South Wales,
Australia.

From time to time one sees in the knotting literature (including '**Knotting Matters**') notes on rope tackles. I wonder if all the authors have ever desperately wanted to shift a heavy weight and only had a length of rope to help. Whenever I have had that experience, I have been most impressed by the enormous friction in all the systems I have used. This friction is due not only to one rope rubbing over the other, but also, and usually most importantly, the rapid transfer of the sharp 180 degree bend along the length of the rope. These notes give some of the results of tests I have made.

The only rope I had available in sufficient quantities was some 2.5 mm diameter braided nylon 'sash cord'. The load to be lifted weighed 11 kg, probably not too far from the safe working load of the rope. I used a spring balance, capacity 26 kg, to measure the pull needed for the lift. The results were a bit variable, but I haven't tried to do any large series of tests. I also measured the effects of replacing the rope 'sheaves' by 10 mm diameter aluminium alloy karabiners (krabs).. I used bowlines in the ends of ropes except where I used triple bowlines, and man harness hitches in the standing part.

A straight lift (System 1 in the diagram), showed the effects of friction: a pull of more than twice the load was needed for an all-rope system, a bit less if I used a karabiner. I tried using a 150 mm diameter metal cylinder to give a gentler bend: the pull needed was much reduced, to 15 kg. A very stiff 4 mm kernmantel nylon rope, that could not form so sharp a bend, needed slightly less pull, 21 kg, in an all-rope system, while a very soft one needed a little more, 24 kg. Some hard-laid 3 mm cotton rope needed more pull: 20 kg over a krab, off the scale (more than 26 kg) for all rope. The only natural fibre rope I had handy was some 11 mm diam manila; this was a bit heavy for the load, which may have helped account for the finding that it needed too great a pull for my spring balance (i.e., more than 26 kg) even when I used a krab. I had no more ropes handy to test.

Very little practical advantage could be obtained by simulations of the ordinary engineers' tackles using a pair of multi-sheave blocks. Systems 2, 4 and 5 simulate what I learned to call whip, gun and heavy gyn tackles (others use different names). System 3 is just a variant of 2 that might be useful if you have several short ropes instead of one long one; 4 has the two upper 'sheaves' tied in the standing part, rather than direct to the anchorage as in 2 and 5. The fact that these systems give little practical mechanical advantage does not mean they are completely useless: they give close control if accurate manoeuvring is needed, and are good for lowering a load.

Systems 6 and 7 are taken from Grover Crowe in 'K.M' no 18, p 26. They have a worrying double cross, where both upper and lower ropes move (this simulates a double sheave block, not a single as suggested by Grover). In System 7 the upper cross did not move at all: friction was too much. Neither of these two systems seem to have any practical advantages. System 8 is the Poldo tackle from the 'Century Guide to Knots', referred to by Cy Canute in 'K.M 10, p10. It is an interesting oddity, but of little use in practice. Although stated to hold a weight without anchoring, I did not find this in my conditions. -

Systems 9 and 10 are the Spanish Burton and Double Spanish Burton, much used by merchant ships, or at least old-fashioned ones. They both give quite useful help. Note the difference between Systems 3 and 9.

System 11 is a variant of the Versitackle from the IGKT Chart no 99. When I tried the original, with the main returns passing three to a loop at each end, I found, as I had expected, that every now and then a return would ride up over another, jamming the whole system solid. However when I used a triple bowline at

Circles represent knots or karabiners:

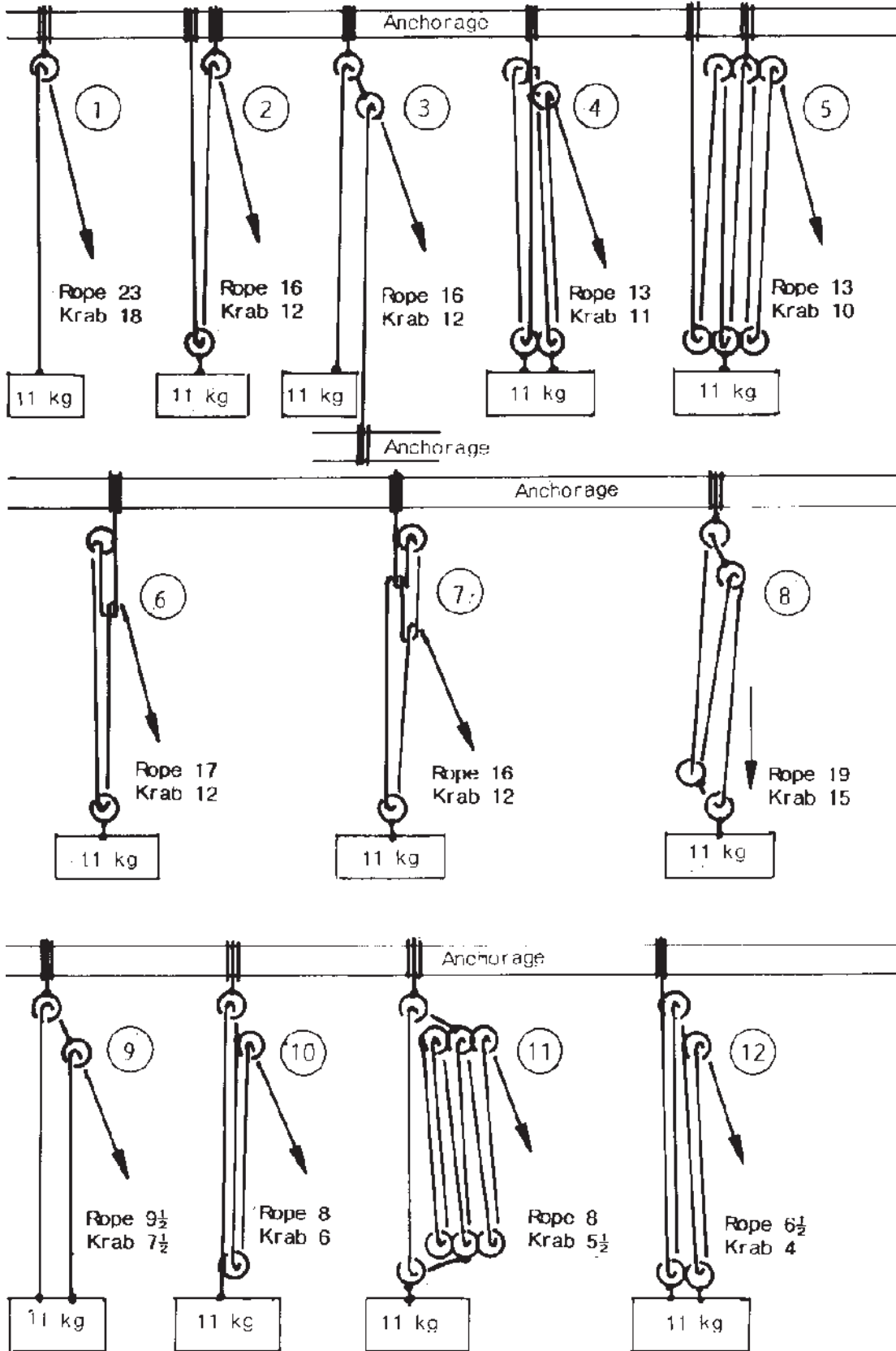

each end, passing each return through a separate loop, this trouble was avoided. This System also gives a useful advantage, though it uses a lot of rope.

The best mechanical advantage was given by System 12, taken from the ‘Century Guide to Knots’ p 116. However, the load was not moved very far before you could pull no more, and again a lot of rope is needed.

All the systems that give appreciable practical mechanical advantages, Systems 9, 10, 11 and 12, suffer from the disadvantage that you cannot move the load close to the point of anchorage. All these properties are summarized in the Table:

Tackle System	Pull, all Rope	Pull,using Karabiners	Distance of Anchorage	Length of Rope needed
2	1.5W	1.1W	H+K	3H+K
3	1.5W	1.1W	H+K	3H+K
4	1.2W	1.0W	H+K	5H+K
5	1.2W	0.9W	H+k	7H+K
9	0.9W	0.7W	2H+K	6H+K
10	0.7W	0.5W	2H+K	8H+K
11	0.7W	0.5W	2H+K	16H+K
12	0.6W	0.4W	4H+K	20H+K

W is the weight you wish to move, H is the distance you wish to move it and K is an allowance for the knots etc in the system (you will need to try it out if the measure is critical). That is, in System 12, you need to pull a little more than half the weight if using an all-rope system, or a little less if using karabiners; the anchorage must be a little more than 4 times the distance you wish to move the load (or the distance you can move the load is a little less than a quarter of the distance of the anchorage); and the amount of rope you will need is a little more than 20 times the distance you move the load, or 5 times the distance to the anchorage.

In conclusion, I would recommend Systems 4 or 5 if you have to get your load close to your anchorage in one pull; otherwise, System 9 if you’re short of rope, 10 for general use, or 12 for maximum advantage. But take every opportunity you can to avoid rope ‘sheaves’. Use a karabiner, or an eye-splicer’s thimble inserted in a tight man harness hitch, or at either end a smooth object of reasonable diameter such as the branch or trunk of a tree with smooth bark or a low-friction covering, or a metal pipe etc.

A rough measure of the practical mechanical advantage of a system can be obtained by dividing the theoretical one by the number of ‘sheaves’. The extra energy you have to exert to overcome friction is converted into heat - and if you are using synthetic ropes you are very likely to melt them. Several of my ‘sheaves’ show considerable melting; I will not be able to use the rope for anything serious again.

It would be possible to increase the mechanical advantage of a system a little by adding on additional tackles, or increasing the number of ‘sheaves’. But sooner or later the weight of the rope used would cancel out any advantage and if the friction gets too great to allow free movement of all the returns, a jamming tangle is the result. Nothing can be expected to be much better than the systems considered here, though some small improvement might result from the use of other kinds of rope.

The parbuckle is also a form of rope tackle. It is intended to be used with a rolling load, so needs a rope with good friction to help overcome rolling inertia. But if you are improvising and using a parbuckle with a non-rolling load, the less friction from the rope the better.

Cartoon

from 'SCOUTING' - March, 1985

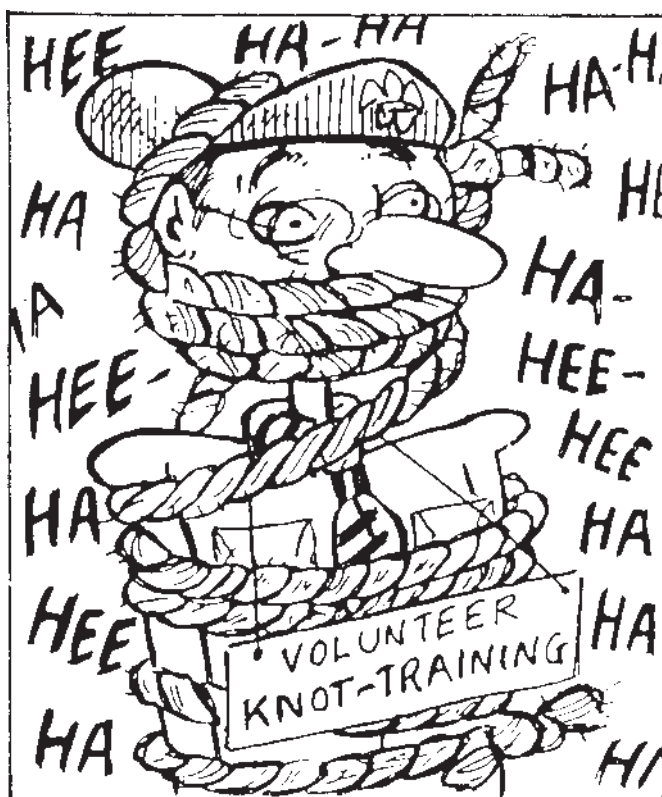

Letters

Dear Geoffrey

Twice recently I have heard references to leaving the reef knot to bandaging and parcels. I agree with all the things to be excluded and with bandaging, but the reef is little use for parcels - surely the packer's knot is the one to advocate for this. Wouldn't it be better to suggest the slip version of the reef for shoe laces, instead of the slip granny so often used? And what about reefing sails where the name of the knot came from? Some of us who sail use it!

October, 1987

Sincerely,

Percy W BLANDFORD

*'Quinton House',
Newbold-on-Stour,
Stratford-upon-Avon,
Warwicks. CV37 8UA,
England.*

Dear Geoffrey,

I fully agree with the Health Warning about the Reef Knot in a previous issue of Knotting Matters where the death of a parachutist was ascribed to his tying a Granny Knot instead of a Reef Knot. What instructor would ever allow a pupil to trust his life to a Reef Knot?

I always advise against its use anywhere and when possible I demonstrate its dangers. The but way to do this is to double one end of a length of rope in the hand, forming a loop. Then reeve the other end through to form the knot (many people tie the Reef Knot this way) but make sure that you go the wrong way around - when the finished knot is held horizontal one tail should be above the rope, the other tail underneath. This looks very much like a Reef Knot but is in fact the deservedly obscure Meadbag Knot. After everyone has agreed that it is a Reef Knot you gently pull the rope and the knot just slides down the rope. This lethal-looking demonstration works especially well with the modern Edeltid Kernmantel climbing ropes and it really scares the hell out of mountaineers.

Follow this up with a real Reef Knot and pull one end and its own adjacent tail apart and the Reef Knot will collapse into a Cow Hitch which will almost fall off the rope all by itself.

Yours sincerely,
T.F. NOLZ

76 October 1987

29 Breadalbane Terrace
Wick,
Caithness KW9 5AT,
Scotland.

Dear Geoffrey,

I happened to be flicking through *The Readers Digest 'GREAT ENCYCLOPAEDIC DICTIONARY'* (Vol. 7 - 'A to L') and on page 455 there was the entry pictured below. I remembered the Celtic design on page 22 of 'K.M.' issue No. 20. They are almost the same; Neil Hood's mat design has one more central crossing.

Yours sincerely,
Charles (J25 DR)
THOMASON

25 November 1997

P.O. Box 1819,
Cairns,
Queensland 4870,
Australia.

tionally adv.
interlāce' v. Bind together intricately, entangle; interweave;

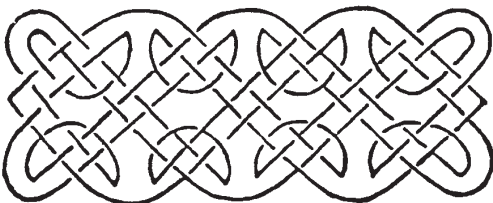

CELTIC INTERLACING
PATTERN

mingle; cross each other intricately. interlāce'ment (-sm-) n.
interlārd' v.t. Mix (writing,

Falmouth & Faröes

2 different ways
to make a full
Carrick Bend

1. The Falmouth Way devised by Owen K. NUTTALL of
Linthwaite,
Huddersfield,
England

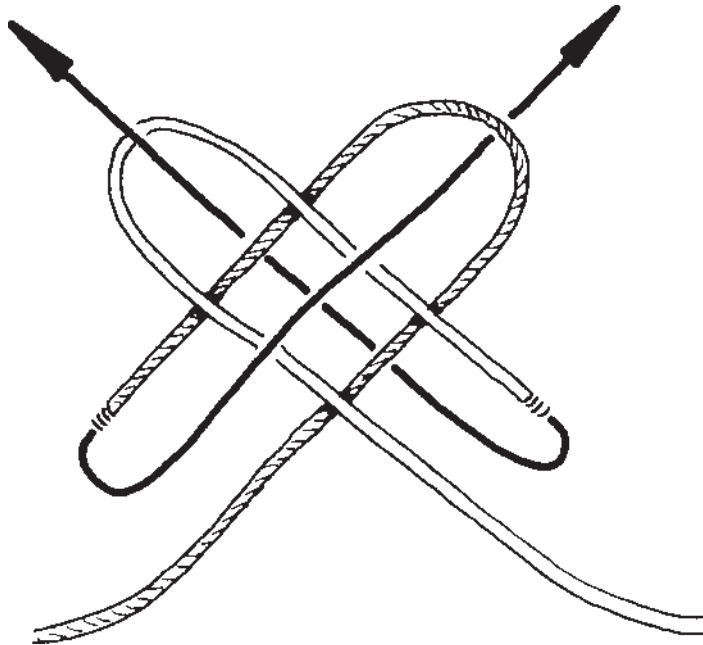

The 'Falmouth Way' is named for all the pleasant hours he spent boating and fishing there (and because the District Motif is the Carrick Bend).

This is a reliable way to learn the bend as the short ends inevitably finish up on opposite sides; and you simply reverse the starting layout (swapping w'ends and stan'ds) to arrive at the Check or Delay Knot

Owen finds that people taught this method of tying the Carrick Bend stay with it. This makes easy progress to the many original variations he has produced which all start from the Falmouth Way. Some of these interesting knots will appear in future issues of 'K.M.' and so the Falmouth Way is commended for that reason.

2. The Faröese Way reported by Pieter van de Griend

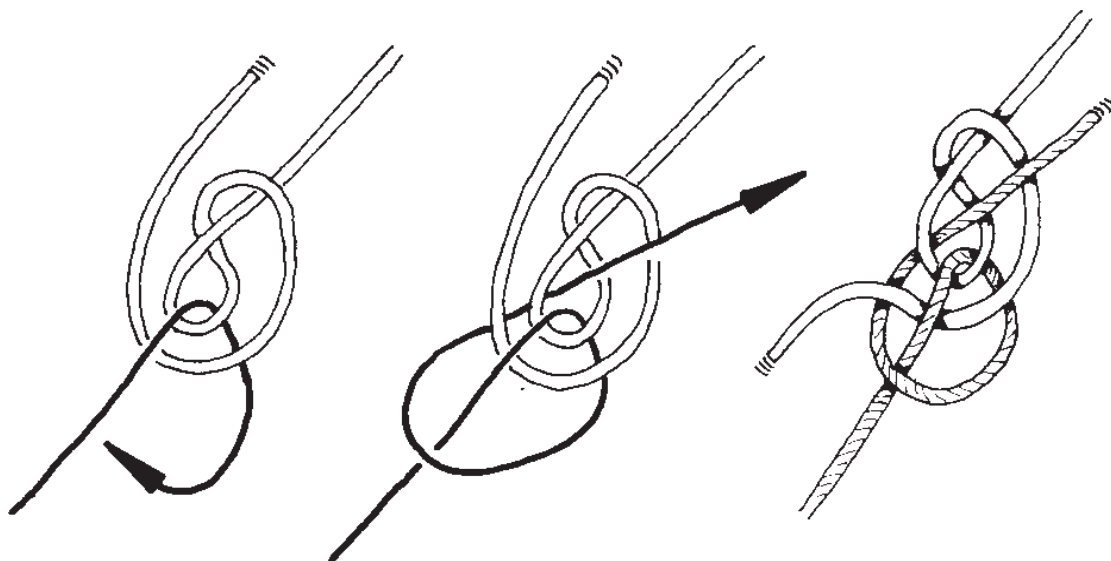

Pieter was shown this method by Walter Thomson, skipper of 'Skugvur FD 940' and also by Torlakkur Hansen of Nolsoy. Hansen told how two men usually did it. One held a rope arranged as illustrated, while the other passed a second line around and through. With thick ropes it was faster and easier this way. Its strength - literally - lies in being tied so that the loops of the completed knot are already formed; there is no need to capsize the bend to bring it taut as there is when tied by the over-&-under basket weave method.

Both men said that it is used by the foroyingur when gillnetting in Greenland. In Faroese the knot is called "Garn Knutur" ("Garn" being the Faroese name for "gillnet"), The Icelanders call the knot "Net Knutur", the name probably coming from the Vestmannaeyar fishermen who were said to be good gillnetters.

The knot is used for tying the lines which hold the nets to the seabottom together. These lines have to stand a lot of strain because the principle behind gillnetting is that you catch the fish behind its gills. The nets are therefore placed perpendicular to the assumed movement of the fish, which is often the direction of the current. So, not only the pressure from the current but also the pressure from the caught fish works on the lines, which thus require strong knots which can be opened up later. The Carrick Bend suffices.

Poem

A PAT FOR TATTING

by R.G.C. Price

Knitting is simple, it leads to no fretting,
Knitting needs little more practise than eating,
While only the clever and good can do tatting.
The tatting of others just turns into knotting:
Only the subtle can handle the shuttle
Only the Tatter can keep in good fettle.
Knitting and tatting need knots less than knotting,
Though tatting needs some knots and knitting needs totting!

Sitting on matting, tatting is fitting,
Though knitting needs comfort and ease in the seating.
You can talk tittle-tattle while knotting or knitting
But tattling while tatting will not be forgiven.
The knitters may natter, the knotters may mutter
Because they attract smaller crowds than the Tatter.
Then hail to the Tatter despising the twitter
Of serious knotter and nit-witted knitter!

Knot Prayers

supplied by Bill MARSHALL
Scout District Commissioner,
Brentwood, Essex, England.

"Throughout this book you will have found odd sentences or phrases printed in blacker type. They are Knot, String or Bead Prayers and are used like this. Find a piece of string which is fairly thick but not too rough. Tie a large knot at one end of it. Then with about 4 cms between each knot, tie eight more knots, thick but small than your first one. Finally tie a tenth knot at the other end, as large as your first. Instead of knots you could use beads. Or you may already possess a rosary and have wondered what to do with it.

When you come to say your prayers using your string, first decide either how many times you are going to use it, or for how many minutes. Next choose one or more of the String Prayers. With the string between your fingers holding the first knot say the prayer. Your fingers move to the next knot and you repeat the prayer and so on until you reach the tenth knot. That is now ready to be the first knot and you begin again. Praying like this is a very ancient practice and a very good one too. The knots or beads keep your hands busy. Repeating the same words keeps your mind busy, enabling your innermost being to concentrate on God, what he is doing, and what he has done.

From 'YOUTH PRAYER' by Brother Kenneth, 1979

Double Braid Splice - Part 2

concluding last issue's article by Neil HOOD in
Western Australia

DOUBLE BRAID ROPE CONSTRUCTION

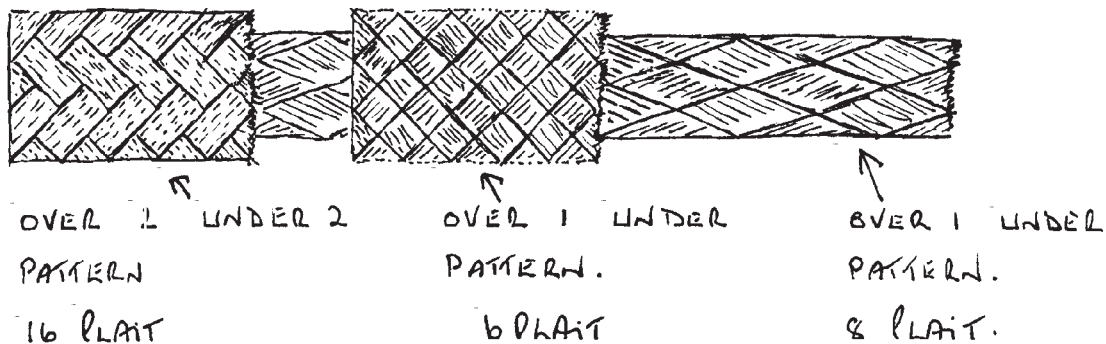

Core: The core is 8-strand plait in which 4 strands rotate clockwise and the other 4 rotate anti-clockwise. The strands interweave in an over-one/under-one sequence as they rotate. Variations in the number of strands and the weave are possible, but unusual: if encountered, they will be found of similar construction to the sheaths.

Sheath: The most common sheath constructions are 8 or 16 strands (referred to as "8-plait" or "16-plait") that are interwoven in an over-one/under-one, or over-two/under-two sequence. Sheaths having other than 8 or 16 strands are fairly rare and, if met, the number will be found to be a multiple of 4 (i.e. 12, 20 or 24 strands). Other weaves such as over-one/under-two are unusual but not unknown.

When splicing ropes having a different number of strands, appropriate division or combining of strands is required. Always follow the weave of the sheath or core into which you are tucking when you are splicing.

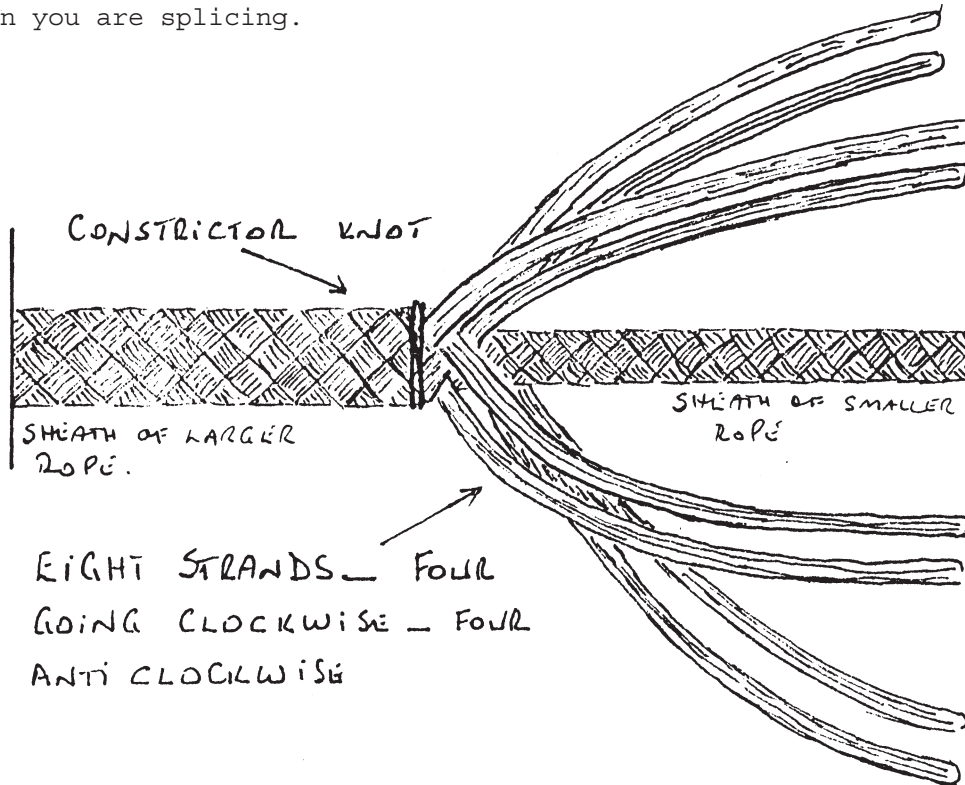

- 8 (a) Smooth the sheath of the largest rope over the join and over the small rope until there is equal tension in both.
- (b) Stop the sheath of the largest rope 5" (12 cm) back from the end.
- (c) Uravel the strands back to the stopping.

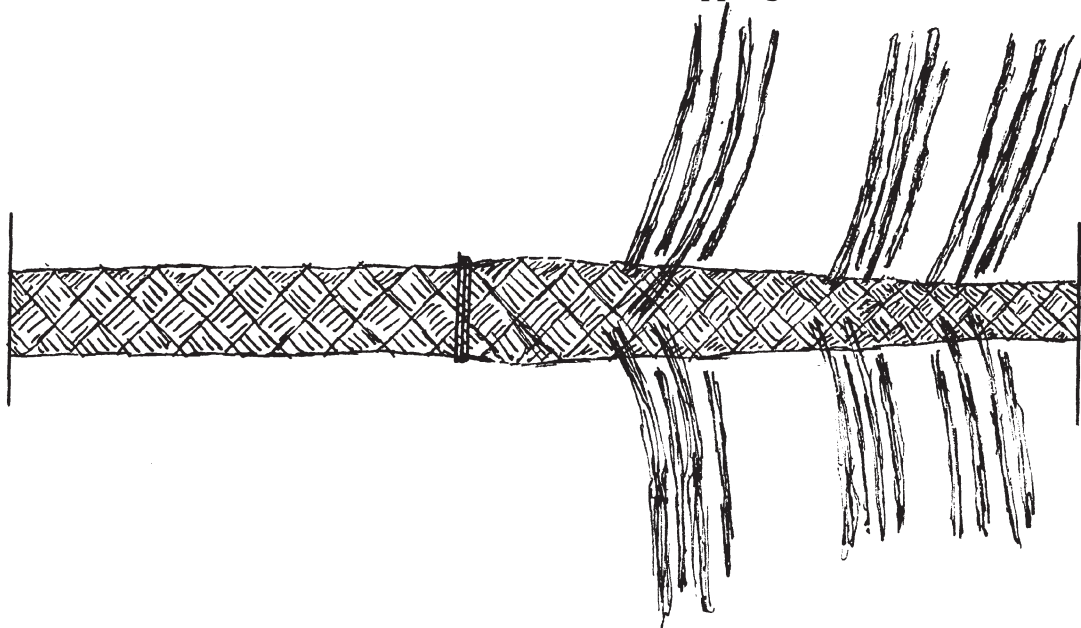

- 9(a) Select the 4 clockwise rotating strands and tuck each strand at least 3 times into the sheath of the small rope.
 (b) Reduce the strands by 1/3rd and tuck a further 3 times.

DO NOT CUT ANY STRAND OR PART OF A STRAND UNTIL THE END-OF
 STEP 10.

- (c) Reduce the strands by ½, and tuck a final 3 times.
 (d) Repeat the tucking and reducing process with the 4 anticlockwise rotating strands.

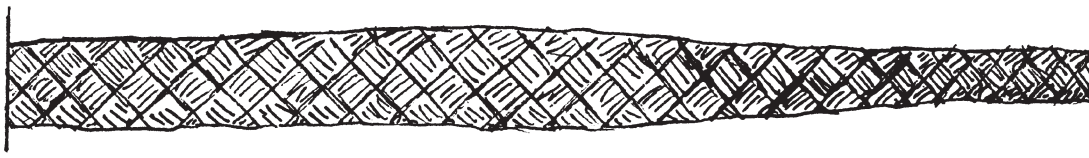

- 10(a) Check that each strand has been tucked firmly and with equal tension.
 (b) Rub the splice firmly between the hands to smooth it.
 (c) Now cut the strands flush with the sheath.
 (d) Remove the constrictor knot. The "Tapered Sheet" is now complete.

Fancy Work

THIS ISSUE'S ILLUSTRATIONS*

OF FIRST-RATE FANCYWORK ARE :-

- (a) 3 BELLROPES used in turn (with others) aboard Her Majesty Queen Elizabeth II's royal yacht 'Britannia'. The outer 2 traditional old designs are of unknown origin. The centre one, actually highlighted in red (the Imperial crown) and blue (the complex Turk's Head) is one of Guild member Charles H.S. Thomason's warship bellropes made in the style of the British parliamentary mace. Many others grace bells at sea with the Royal Australian Navy.
 (b) I.G.K.T. craftsman Stuart E. Grainger produced the nice and original half-hitched nursery playbrick, which is stuffed with foam; also the very practical yet splendidly handsome laundry basket.

(Both items are from his catalogue of commercial ropework products which he will make to order for you.)

* See final page....

KNOT CHARTS

Each chart is on one side of paper the same size as this sheet and deals completely with the subject of its title. Binders for charts are available consisting of printed front and plain back flexible card. Capacity up to about 40 charts. Order by numbers shown below.

1. Turk's head mat and hitch mat.
2. Lanyard knot.
3. 3-lead 5-bight Turk's head.
4. Monkey's fist.
5. ocean plait mat.
6. 4-lead 3-bight Turk's head.
7. Sailmaker's whipping.
8. Common whipping variations.
9. Basic eye splice.
10. Back.splice.
11. End of a rope.
- 12 Rustler's (square) knot.
- 13: Sheet bend variations.
14. Sheepshank variations.
15. Clove hitch variations.
16. Constrictor knot.
17. Chinese lanyard knot.
18. Turk's head (12-bight 5 lead).
19. Mat tied with a single cord.
20. Celtic knot design.
21. Knob covering.
22. A square mat.
- 23 to 48 are alphabet of knots for decorative use on clothing or notice boards. Letter is indicated after the chart number: 23A,24B, 25C,26D,27E,28F,29G,30H,31I,32J, 33K,34L,35M,36N,37O,38P,39Q,40R, 41S,42T,43U,44V,45W,46X,47Y,48Z.
49. Scaffold hitch.
50. Highwayman's hitch
51. Multiple bowlines.
52. Coach whipping.
53. 3-lead 4-bight Turk's head.
54. Bead puzzle.
55. Rosenthal Zeppelin knot.
56. Hunter bend.
57. Pole hitches.
58. Perfection loop.
59. Crown knots.
60. Crown knots continued.
61. Star knot.
62. Bottle (or jar) sling.
63. Back mooring hitch.
64. Full (or double) carrick bend.
65. Tumbling thief knot.
66. Netting knot.
67. Sailmaker's eye splice.
68. Eye splice with collar.
69. Wire splice, over and under.
70. Endless three-part plait.
71. Chain splice.
72. Macrame knots-1.
73. Macrame knots-2.
74. Spectacles neck-cord.
75. Basic picture frames.
76. Four-strand sinnets.
77. A circular mat.
78. Rectangular mat pattern.
79. 5-bight 3-lead Turk's head.
80. 7-bight 4-lead Turk's head.
81. True lovers' knot.
82. A simple lanyard.
83. Make a-cowboy belt.
84. Carrick bend and variations.
85. Necklace in Chinese knotting.
86. Macrame knots-3.
87. Macrame knots-4.
88. Connecting knots.
89. 7-bight 5-lead Turk's head.
90. 5-bight 4-lead Turk's head. (79,80,89,90 formed round fingers).
91. Square lashing.
92. Diagonal lashing.
93. Shear lashing.

Newer charts

94. Prolong knot. 95. Overhand knot, using forceps. 96. Figure-eight knots using forceps. 97. Surgeons knot, using forceps. 98. 4-bight 3-lead Turk's head (formed on fingers). 99. Versitackle. 100. Theodore knot (formed on fingers).

Prices: Charts 10p each. Binders 25p each.

POSTCARDS. Eight glossy postcards by Stuart Grainger, each providing instructions for a knot. 15p each. order by letter. A. 3-lead 4 bight Turk's head. B. Ropefolk. C. Coachwhipping. D. Star knot. E. Ocean plait. F. Manrope knot. G. Diamond rose knot. H. 3-lead 5 bight Turk's head.

I.G.K.T. SUPPLIES Obtainable at meetings or by mail from the Assistant Secretary (supplies): Mrs. Ivy Blandford, Quinton House, Newbold-on-Stour, Stratford-upon-Avon CV37 8UA, England (Tel. Alderminster [078 9871] 257).

Postage and packing: Guild profit margin is small, so help by allowing sufficient for packing and postage. These rates should cover internal mail in Britain: orders - up to £1 28p. up to £2 35p. up to £3 45p. up to £4 55p. up to £6 65p. from £6 to £12 £1. For European countries it is about double these rates. Use British currency, if possible. For other currency we have to pay a bank commission, so allow extra to cover this. If you want air mail (outside Europe), allow adequately.

For countries further away postage is more expensive. The following examples of mail to the U.S.A. are offered as a guide:

	Air Mail		Surface Mail	
	sealed	unsealed	sealed	unsealed
9 books	£14.25	£7.20	£3.60	£2.30
2 books	£5.10	£2.65	£1.50	£0.86
100 charts	£7.90	£4.05	£2.80	£1.90
50 charts	£4.45	£2.30	£1.30	£0.95

BADGE Round metal enamel pin badge with the Guild name and the same knot emblem. as on the magazine cover. £1.50 (we pay postage)

CLOTH BADGE 3 inch diameter with name and knot symbol, gold on blue. 75p.

TIE Attractive blue tie with pattern of knots in white £4.50

BOOKS (Card-covered booklets, published by the Guild as a service to member. They are limited editions with information mostly available elsewhere. Page size as this sheet, except where marked A5, which is half this size.

BREASTPLATE DESIGNS to make and wear. By Brian Field. 27 pges. The decorative designs which formed the basis of pendants worn by sailors and their girl friends. A very thorough treatment. £2.50p.

AN INTRODUCTION TO KNOT TYING AND FANCYWORK. By Stuart Grainger. 38 pages. Some basic knotting, leading to needle hitching; the author's speciality. Making articles and covering objects, using the half-hitching technique. £3.80.

TURK'S HEAD THE TRADITIONAL WAY By Eric Franklin. many forms of the commonly used versions of the Turks' Head, with step-by-step drawings. £1.50p.

SOLLY'S SINGLE STRAND STAR and variations on the theme. By Stuart Grainger. The production of a form of grommet in several variations, for such uses as edging trays and making napkin rings. 8 pages. £1.00

SOME SPLICES AND LANYARD KNOTS By Stuart Grainger. 30 pages. Most of the splices and knots made with strands. £3.25

ROPEFOLK By Stuart Grainger. 14 pages. Using knots and splices to make decorative animals. £1.75

LASHINGS for scaffolding and pioneering. By Percy W. Blandford. 36 pages. All the lashings and techniques used for traditional methods of joining poles, with design note.. A5 booklet. £2.00

A NEW SYSTEM OF KNOTTING By Dr. Harry Asher. Well illustrated exposition of Harry Asher's systematic approach to knotting. In two stapled volumes. volume 1 (50 pges) £1.85. volume 2 (37 pages) £1.40

continued

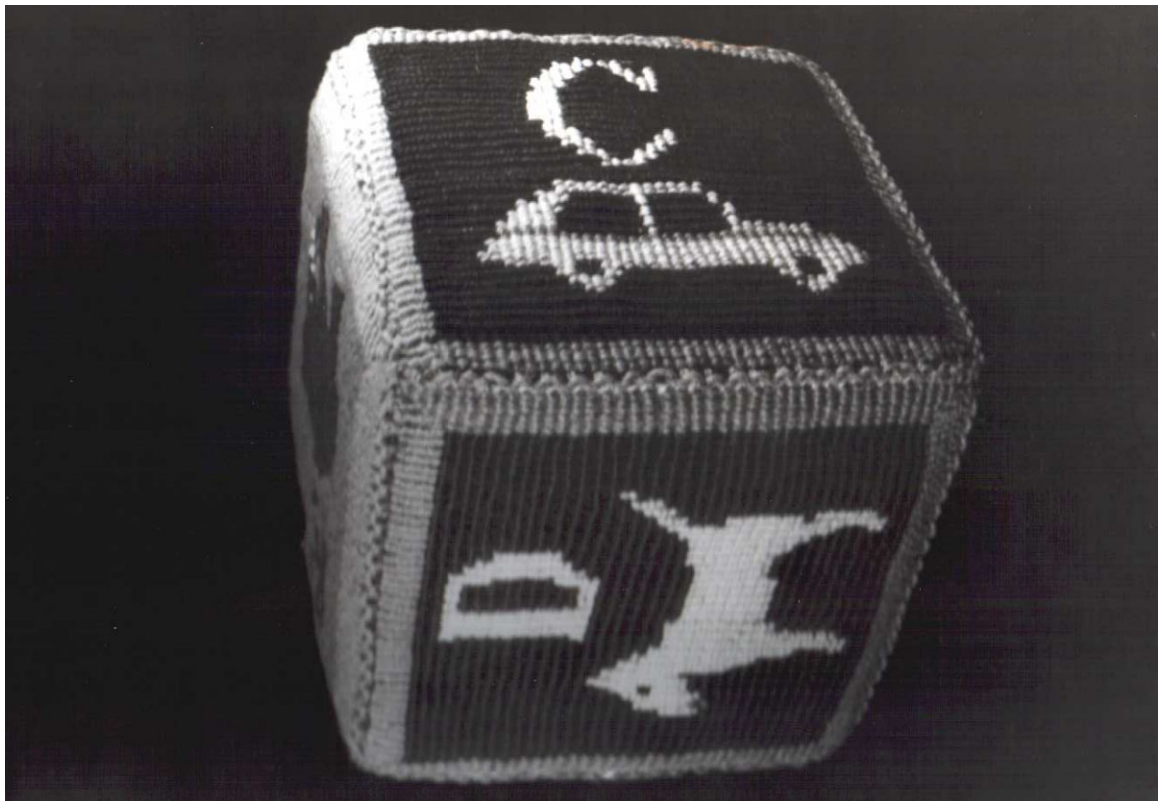
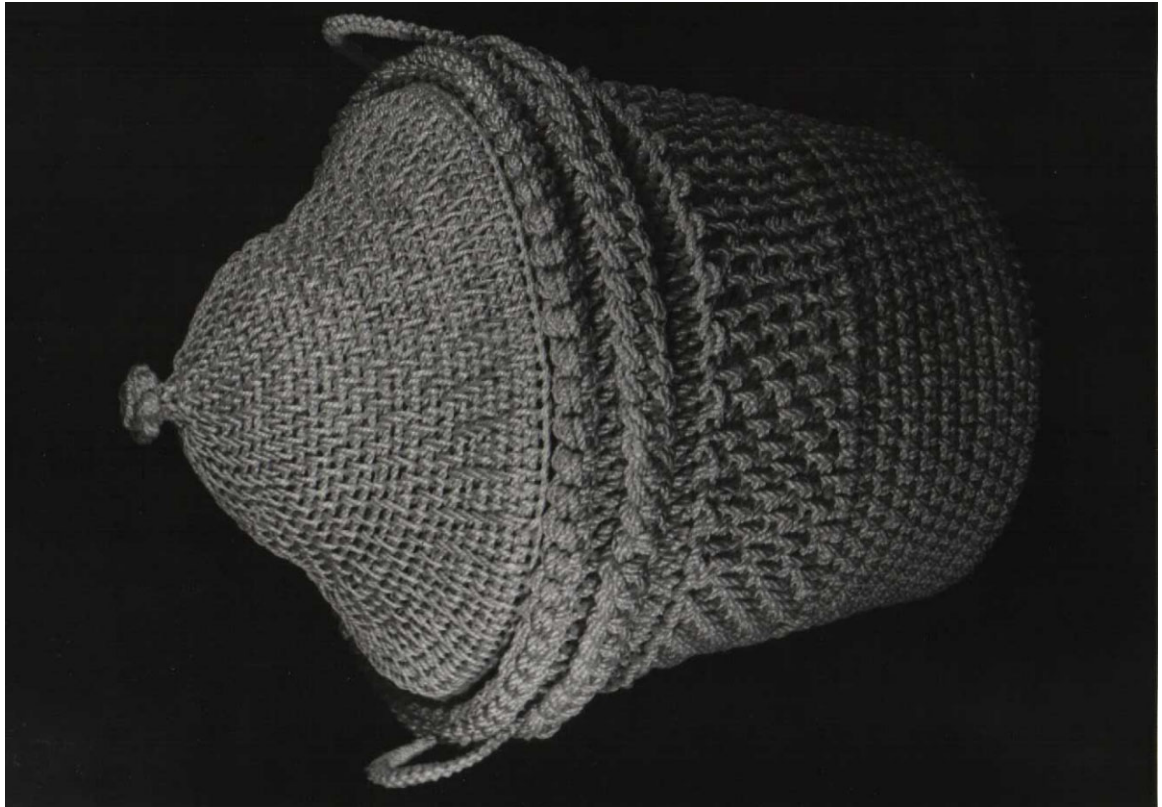



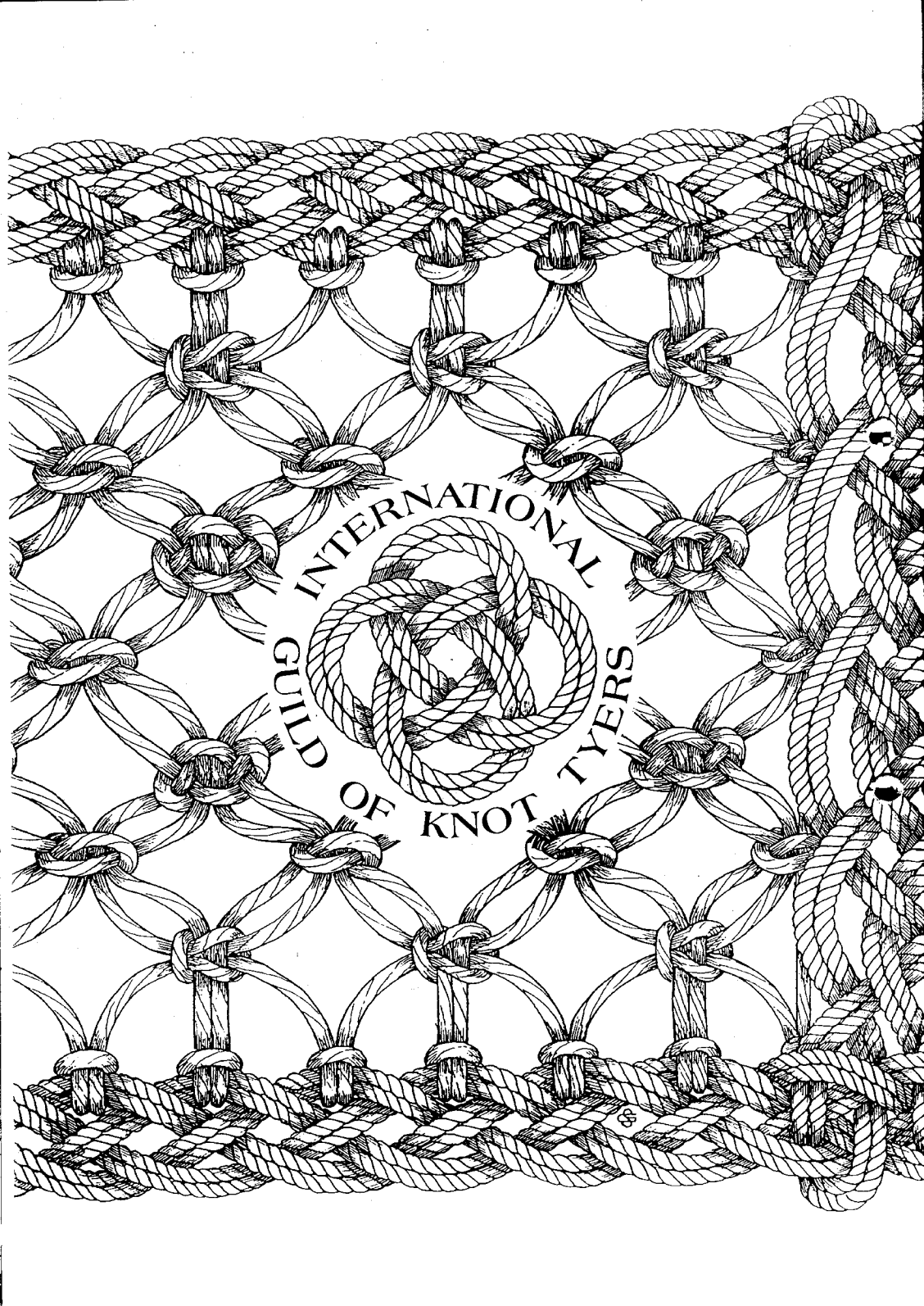

INTERNATIONAL
GUILD OF KNOT TYERS