

RETS
PRACTICAL GUIDE BOOK
SERIES

CARPENTRY
and
WOODWORK

(Reprint - July 2014)

RAILWAY ENGINEERING TECHNICAL SOCIETY
PUNE - INDIA

RETS

PRACTICAL GUIDE BOOK SERIES

CARPENTRY AND WOODWORK

COMPILED BY

S. N. Pophale

Section Engineer, IRICEN, Pune

EDITED BY

A. K. Goel

M. Tech. (Str. Engg.), FIE (India), FIE (IPWE)

Director, IRICEN, Pune

**RAILWAY ENGINEERING TECHNICAL SOCIETY
PUNE (INDIA)**

Published By

Railway Engineering Technical Society, Pune
C/o IRICEN, Near Railway Station, Pune 411 001

© Copyright reserved with RETS, Pune

First Published 2008

Price Rs. 70/-

Designed & Printed by

M.R. & Co.

1552, Sadashiv Peth,
Chimanbaug, Pune 411 030

PREFACE

The various skills, trades required in building construction and maintenance in India have been traditionally inherited by the artisans from their families or learnt under Master craftsmen. With change in economic scenario in India, traditions are fast breaking and few Institutes like I.T.I.s which train the artisans, are inadequate to meet the requirements of the fast growing building Industry. Govt. rules do not encourage any induction of fresh artisans in the Govt. departments and with more and more outsourcing of works to contractors, the departmental staff who get promoted to skilled category, do not get opportunity of learning skills from their seniors and sometimes lack even the basics of the trade. Further, government-funded projects, are awarded on lowest tender basis and the past experience of the tenderer in terms of money value makes him eligible for bagging the work, without specific reference to the quality of the work or the skills employed. Thus, Government departments are neither inducting trained artisans nor give premium to good workmanship of Contractors and the responsibility falls on the Field Engineers to extract good quality work from the semi-skilled artisans. Further, there is practically no structured training for the artisans to learn good workmanship and as a result the quality of work suffers.

Indian Railways are constructing and maintaining thousands of crores of rupees worth of buildings every year and upgrading the skills of the carpenters, either railway employees or demanding better workmanship from private contractors, surely will go a long way in improving the returns on the investment. Several new materials such as ply boards, fiber boards and aluminum extruded sections etc., have flooded the market and are being adopted in Railways also in good proportion. IS Codes, Manuals, give the specifications of the material but the workmanship is left to the individual carpenters as the procedure for working such materials and the finishes acceptable have not been standardized. The Practical Guidebook on 'Carpentry and Woodwork' attempts to fill this gap in a limited way. The compilation has been done in a short and crisp manner, explained in sequential steps with abundant sketches and illustrations so as to be digested by even the literate artisans. The main focus is on the carpentry work for building construction and maintenance including new materials, aluminum doors/windows, glass and glazing, sloped roofs etc.,

The material has been compiled by Shri S.N.Pophale, Section Engineer/IRICEN under the guidance of Shri N.R. Kale, Assistant Executive Engineer/IRICEN by talking to several artisans, contractors, suppliers and manufacturers and also referring to some Hand books and codes. The treatment of the subject has been kept 'to the point' purposely for the use of field Engineers and it is not a comprehensive treatise on the carpentry and woodwork. It is hoped that it will grow by time with contribution and suggestions from readers, which are sincerely solicited.

11.9.08



President, Railway Engineering Technical Society, and
Director, Indian Railways Institute of Civil Engineering,
Pune- 411 001

CONTENTS

Page No.

Chapter 1 : CARPENTRY TOOLS

1-13

- 1.0 Hammer
- 2.0 Saw
- 3.0 Drills
- 4.0 Marking Tools
- 5.0 Miscellaneous Tools
- 6.0 Working of important tools
- 7.0 Grinding and Sharpening of Tools

Chapter 2 : WOOD FOR CARPENTRY WORK

14-23

- 1.0 General
- 2.0 Hard wood
- 3.0 Soft wood
- 4.0 Manufactured woods
 - 4.1 Plywood
 - 4.2 Particle board
 - 4.3 Laminated softwood board
 - 4.4 MDF (Medium Density Fibreboard)
 - 4.5 Block board
 - 4.6 Gypboard
- 5.0 Laminates
- 6.0 Timber - rotting problems

Chapter 3 : NAILS, HINGES AND FIXING MATERIAL

24-41

- 1.0 General
- 2.0 Nails
- 3.0 Wood Screws
- 4.0 Hinges
- 5.0 Tower bolt
- 6.0 Aldrops
- 7.0 Safety Hasps
- 8.0 Right angles and Tee's
- 9.0 Door closers
- 10.0 Sandpapers
- 11.0 Synthetic glues

Chapter 4 : WOODWORK JOINTS **42-55**

- 1.0 Mortise and tenon joints
- 1.1 Halved joints
- 2.0 Commonly used Mortise and Tenon Joints
- 3.0 Halved and Mitre Joints
- 4.0 Other types of 'T' Joints
- 5.0 Splice Joints
- 6.0 Procedure for Correct Wood Working (Making a frame)
- 7.0 The working and making joints
- 8.0 Tips for correct wood working

Chapter 5 : DOORS AND WINDOWS **56-76**

- 1.0 General
- 2.0 Doors :
 - 2.1 Door Frames
 - 2.2 Door Shutters
 - 2.3 Making a flush door
 - 2.4 Panelled Doors
 - 2.5 Glazed Doors
 - 2.6 Wire gauge shutters
 - 2.7 Battened / ledge Doors
 - 2.8 G.I. Sheet Doors
- 3.0 Procedure for Fixing door shutters
- 4.0 Windows
- 5.0 Ventilators
- 6.0 Fixing the fittings

Chapter 6 : ALUMINIUM SLIDING WINDOWS **77-88**

- 1.0 Introduction
- 2.0 Material
- 3.0 General arrangement
 - 3.1 Procedure for making Frame
 - 3.2 Fixing tracks to frame
 - 3.3 Making Shutters
 - 3.4 Fixing shutters in the track
 - 3.5 Checking

Chapter 7 : GLAZING **89-96**

- 1.0 Glass
 - 1.1 Types of Glass
 - 1.2 Guidelines for use of Glass in Structures
 - 1.3 Four sides framed glass

- 1.4 Two / Three sides Framed Glass
- 1.5 Frameless / Non-framed Glass
- 1.6 Point Supported glass
- 2.0 Fixing glass
 - 2.1 The fixing of glass on wooden frame
 - 2.2 Putty for glass fixing
 - 2.3 Glazed walls
 - 2.4 Lead wings

Chapter 8 : SLOPE ROOF AND FALSE CEILING

97-119

- 1.0 Pitched or sloping roofs
- 2.0 Trusses
- 3.0 Spacing of purlins
- 4.0 Corrugated Galvanized Iron Sheet / A.C. Sheet Roofing
- 5.0 Laying of corrugated sheets
- 6.0 False ceiling
 - 6.1 Types of false ceiling
 - 6.2 Types of Frame
 - 6.3 Process for installation of Aluminium False Ceiling

Chapter 9 : LAMINATION

120-125

- 1.0 Fixing Lamination on Surfaces
 - 1.1 General
 - 1.2 Steps involved in lamination

Chapter 1

CARPENTRY TOOLS

1.0 Hammer

It is a basic tool of the carpenter and is used as a striking tool, to drive nails and work various tools like chisel, nail punch, fix dowels etc.

1.1 The various parts of a hammer are shown below:

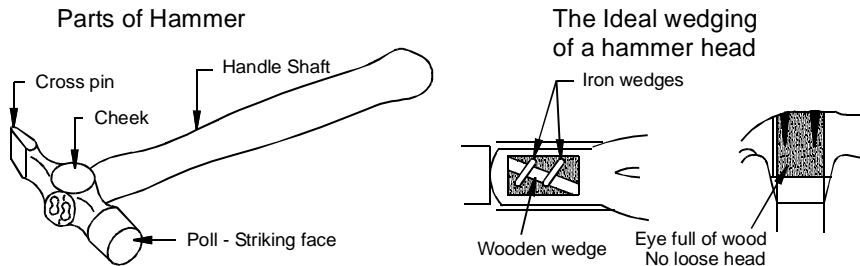

1.2 There are different types of hammers used by carpenters for different works. Commonly the hammers used by carpenters are:

- i) Wooden Mallet
- ii) Claw Hammer
- iii) Warrington Hammer
- iv) Pin hammer

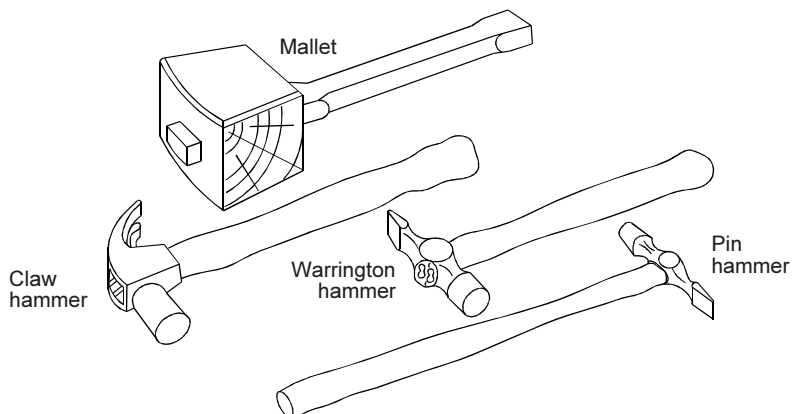

- i) **Wooden Mallet** : It is mainly used to strike the chisel for working.
- ii) **Claw Hammer** : It is the main hammer of the carpenter and it weighs about 500 gm. It has poll on one side and claw on the other. The claw is used to pull out nails from the wood work, either which get bent during driving or required for some other reason.
- iii) **Warrington Hammer** : It is the next heavier hammer, weighing about 250 gm and is used for medium heavy work of driving nails.
- iv) **Pin Hammer** : The weight of the Pin hammer is about 110 gm and is used to drive small nails or pins. The poll of the hammer is the main striking face and the Pin is to start the nail driving holding the nail between fingers.

2.0 Saws

The cutting ability of a saw blade depends upon three measurements,

- Rake
- Pitch
- Set

- i) **Rake** : This is the angle at which the teeth are ground

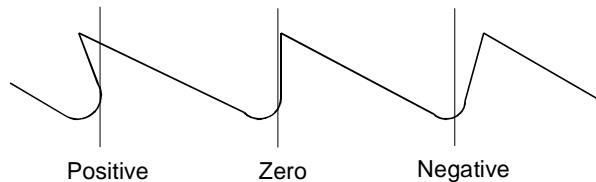

- ii) **Pitch**:

This is the number of teeth per inch on the blade.

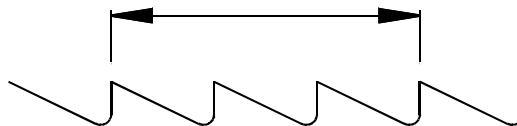

- iii) **Set**:

The teeth are offset(bent) on each side of the blade on a straight set blade, on fine toothed blades they may have a wavy set in which several teeth in a row will be offset to the same side.

The distance across the points of the teeth is known as the width of the cut.



2.1 Saw Types

2.1.1 Back (Tenon) Saw:

A handsaw has a rectangular blade with a reinforcing rib along the back. This is used for more precise cutting, such as dovetails, mitres or tenon joints etc. Because of stiffened edge they can cut to limited depth. These have relatively more pitch and little or no set.



2.1.2 Handsaws:

Handsaws are available in many sizes and configurations, a good general purpose saw is 26" long and has 8 teeth per inch. Crosscut saws (to cut across the grain) have teeth with a negative rake, ripping saws (to cut in the direction of the grain) have a zero rake. The saws shown above are used if the job piece is held in the vice on a work bench, however, in India carpenters also work holding the job piece between their toes, and cut in the sitting posture. The cutting stroke is towards ones body as against away from body in case the piece is held in vice and the rake of the saws is reverse i.e. sloping tooth is towards the handle.



2.1.3 Keyhole or Compass Saw:

These saws have narrow blades to cut along curves or short distances. To start inside cuts one or more holes are drilled, depending on the shape of the cut-out. For longer inside straight cuts, the keyhole saw is used to make a cut long enough so that a regular handsaw can be inserted to finish the cut.



2.1.4 Coping Saw:

These saws use very narrow blades so intricate designs can be cut. The blade can be rotated a full 360° to negotiate tight corners. Inside cuts are started by drilling a small hole to allow the blade to pass through it, then the blade is inserted into the saw

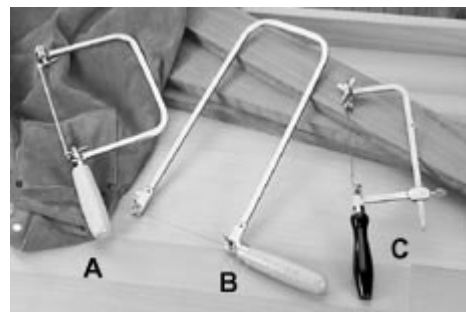

frame. Deep throated saws called scroll saws with frames having 18" clearance are available.

2.1.5 Traditional Frame/Bow Saws:

Frame saws are useful tools for a great many jobs—often called bow saws, the traditional shape has two hardwood handles separated by a wood bar, with the blade below the bar and a twisted wire or cable above. The result is a, H shape that makes handling very easy. The wire is turned and tightened to add tension to the blade, which then cuts straight and true.

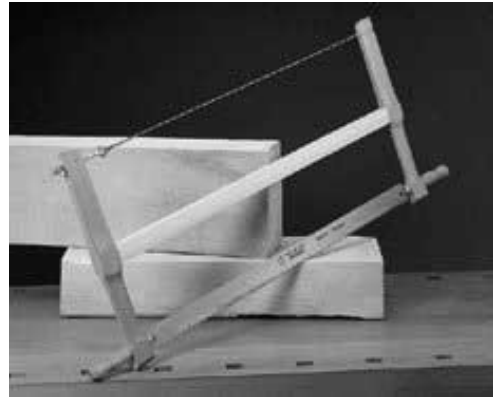

3.0 Drills

The size of the drill is determined by the maximum drill bit shank that its chuck can accommodate.

Used primarily for boring holes in nearly all materials, the electric drill can also be used for a variety of other tasks, facilitated by a number of accessories and attachments. These include sanding, screwdriving, grinding, and mixing paint to name but a few.

3.1 The Different types of drills

3.1.1 Hand Drill:

Uses a hand operated crank handle to turn an interlocking gear, which in turn rotates the drill bit. With a quicker set-up time than the electric drill, the hand drill is most useful when one requires only a small number of holes. Effective for drilling into wood, soft metal, and plastics, hand drills will generally accommodate most drill bits up to 6mm (1/4") in diameter in either keyed or keyless chucks, and can also be used for screwdriving.

3.1.2 Miniature Hand Drill:

Particularly useful for fine work, such as model making, the miniature hand drill bores holes with very small, high-speed steel bits. Useful for making pilot holes for small screws, some models have collets at both ends allowing the user to have different size drills available without having to change the bit.

3.1.3 Brace:

Similar to the hand drill, with the drill bit being rotated by manually cranking the handle whilst applying pressure. Effective for drilling into wood, the brace will generally accept larger drill shanks than the hand drill, and can also be used for screw driving. Some models have a ratchet fitted to the

chuck, allowing the user to drill/drive in places where a full rotation of the handle is not possible.

3.1.4 Electric Rotary Drill:

The most basic of the electric drills, the rotary drill is used mainly for boring holes in a variety of materials. These can be either mains-operated (i.e. corded), or battery-operated (i.e. cordless). Different functions incorporated into some models include variable speed and reversing, and attachments can be used to enable different functions, such as sanding and grinding.

3.1.5 Auger: An auger is a device for boring by removing material by means of a rotating in helical pattern. The shaved material is moved along the axis of rotation.

3.1.6 Bradawl:

It is used to bore small holes. This is operated with pressure from top by hand and drive it as screw driver. This is mostly used to make pilot holes or clearance holes of small diameter, in thin members.

4.0 Plane:

It is used to level and plane the wood surface. There are three distinct planes, namely, the jack plane, the beading plane and rebate plane, to work at all the surfaces required to be planed.

4.1 The Jack Plane

This plane has the cutting edge of its blade ground so it is slightly curved because, as the bit must be driven out so it will take a deep bite into the rough surface of the wood, the curved cutting edge prevents the corner edges of the bit from digging into the planed surface.

BORING HOLE
Boring small holes

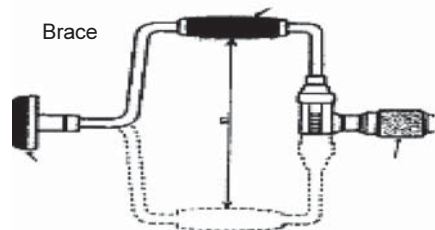
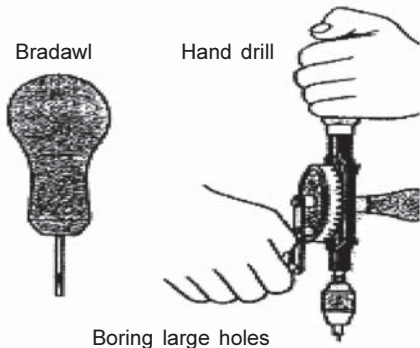

Method of use

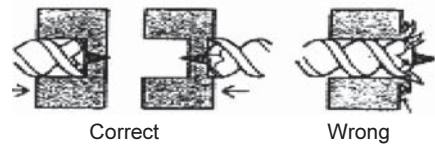

Correct

Wrong



Auger

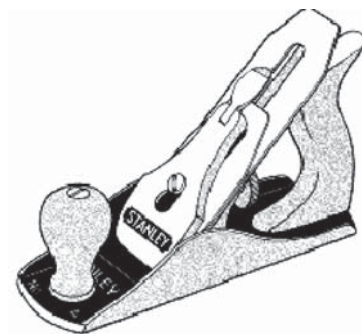

Jack plane bit

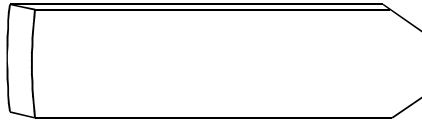

On the other hand, the bits of the smoothing and finishing planes are ground straight across their cutting edges. The bit is ground at 25° and at the edge hoveed at 30° .

4.2 Beading Plane:

This plane has an adjustable blade. It is used for smoothing or shaping the wood for the fine work. It cuts less material as compared to Jack Plane.

4.3 Rebate Plane:

This plane is used to cut wood along the grains. It is normally used to cut recess, shoulders and rebates. This plane is small in width. The blade of the plane slightly comes out of the body.



Rebate Plane

4.4 Plough Plane:

It is used to produce grooves of different size.

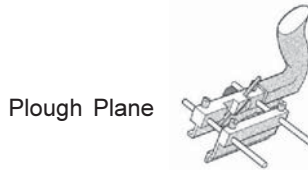

Plough Plane

5.0 Marking Tools

5.1 Try Square or Carpenter' Square:

Try squares are L-shaped, with a thin metal blade that is marked in graduations like a ruler and a "STOCK" called the body, which is thicker than the blade. For woodworking, the body is typically made of wood, while machinists use a variation that has a metal body.

Try squares are used primarily to mark a straight line across a piece of wood for cutting. The thicker body of the square is placed against the edge of a piece of wood and the blade is placed on top of the wood, which ensures that the blade is then exactly perpendicular to the edge of the board. The thicker body of the try square also allows it to be placed flat on a table or tool with the blade sticking up in the air, making this a useful tool for measuring things, such as



the height of a table saw blade or router bit etc.

5.2 Marking Gauge:

This is simply a straight bar, with a sharpened point projecting out on one side near its end, and having an adjustable sliding head or cheekpiece. This tool is used for marking straight lines parallel to one edge of piece and is very important in making mortises or tenons, because the sharpened steel point which projects from the side of the bar, serves to outline and define the edges of the mortises or tenons.



6.0 Miscellaneous Tools

6.1 Screwdrivers

Screwdriver is used to drive the screws. Only proper screw driver should be used i.e. full consideration should be given to the type of head, drive and size of the screw. Improper screw driver not only will damage the screw head but also may cause injury to the workman. The screws should not be hammered to fit into the wood. The screwdriver is to be operated with both the hands so that it should not be slipped from screw. Carpenter's screwdriver has a broader handle compared to others to apply adequate pressure to the screwdriver.

Use correct size screwdriver

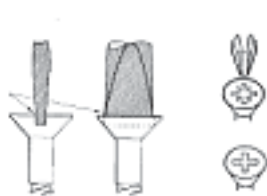

Never use a screwdriver with rounded edge or tip



Worn tip damaged screw

Damaged screws



6.2 Pincer - This is used to remove small nails from wood.

6.3 Plier - The plier is used to hold or remove the nails.

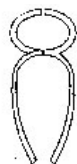

Pincer



Plier

7.0 Working of important tools

7.1 **Jack Plane** - The correct posture and the stance is given in the fig. below:

Long edges require long planes



Stance and action of planing



To keep the plane straight press down on the knob at the beginning of the stroke and down on the handle at the end of stroke.

How to plane end grain

Blade maintenance

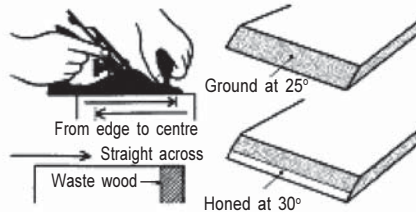

- For longer edges or surfaces to be planed, longer planes are required.
- To keep the plane straight, press down on the knob of the beginning of stroke and down on the handle at the end of stroke.
- The jack plane is handled with both hands, and the smoothing plane with one hand, but only when used for dressing the ends of boards. For other uses both hands are required.
- Before commencing to plane a board, observe the direction in which the grain of the wood runs. This precaution will save many a piece of material, because if the jack plane is set deep it will dig into the wood and cause a rough surface.
- Never move the jack plane or the smoothing plane over the work so that the body of the tool is in a direct line with the movement of the plane. It should be held at an angle of about 20-25 degrees (see Fig).
- Never draw back the plane with the bit resting on the board. This wears out the tool, and if there should be any grit on the board it will be sure to ruin the bit. This applies particularly to the jack plane, but is bad practice with the others as well.

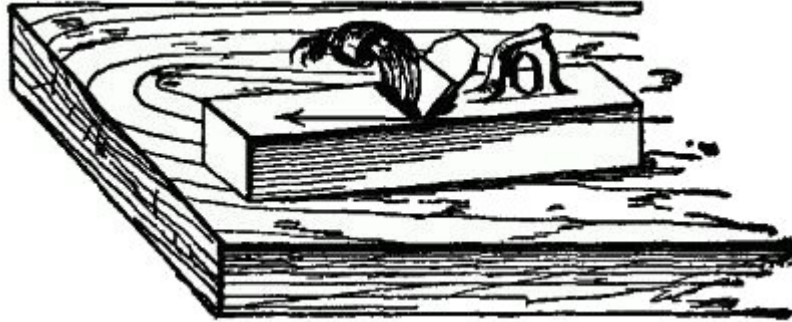

Angle of moving plane

7.2 Plough Plane: Stance is same as for jack plane.

- a) Work should be started from the far end of the job.
- b) Take succession of cuts working towards the other end.

7.3 Saw:

- a) The saw should be held perpendicular to cutting edge. The saw should not be held on the line. The work should be so laid out that the saw cut is on the discarded side of the material. Little material must be left for trimming and finishing.

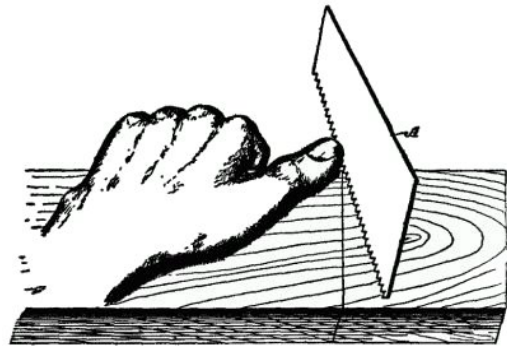

Starting Cut of saw

- b) The saw should be firmly held by the hand during the initial cut or two, duly guided by the thumb, afterwards always hold the handle loosely.
- c) The first stroke should be upwardly, not downwardly. While in the act of drawing up the saw we can judge whether the saw blade is held by the thumb gauge in the proper position to cut along the mark, and when the saw moves downwardly for the first cut, you may be assured that the cut is accurate, or at the right place, and the thumb should be kept in its position until two or three cuts are made.
- d) For ordinary cross-cutting the angle of the saw should be at 45- 60 degrees. For ripping, the best results are found at less than 45 degrees, but avoid flattening down the angle. An incorrect as well as a correct angle are shown in Figs below.



7.3.1 To make a cross cut:

Cross cuts go against the grain, mark the cut with a square, guide the side of the blade with the knuckle of your thumb. Start the cut by pulling up on the handsaw two or three times, then push the saw forward at about a 45° angle, continue with full even strokes. In case of Indian saw the pushing is required in place of pulling and vice-versa.

7.3.2 To make a rip cut:

Rip cuts go in the direction of the grain of the wood, mark a line to follow, start the same way as cross cutting, then continue with full strokes at about a 60° angle. If it is a long cut use a wedge to spread the wood apart.



7.4 Working with Marking Gauge:

The gauge should run straight. The gauge should hold properly to run it straight. It should be observed in figure that the hand grasps the stem of the gauge behind the cheek-piece, so that the thumb is free to press against the side of the stem to the front of the cheek-piece.

The hand serves to keep the cheek piece against the board, while the thumb pushes the gauge forward. The hand must not, under any circumstances, be used to move the gauge along. In fact, it is not necessary for the fingers to be clasped around the gauge stem, if the forefinger presses tightly against the cheek piece, since the thumb performs all the operation of moving it along. The hand grasps the tool in order to hold it down against the material, and to bring it back for a new cut.

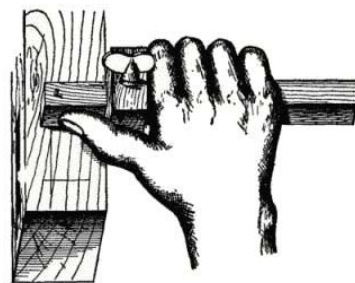

Holding Gauge

8.0 Grinding and Sharpening of Tools

There is a principle involved in the sharpening of every tool. There is a particular way to grind the bits of each tool. A chisel cannot be made to do good work unless its cutting edge is square and at the right working angle. The saw will not work unless set properly. The saw not only requires sharpening but also setting and requires good skill. The procedure is explained here under.

8.1 Saws:

8.1.1 How to Set: setting a saw means to set the teeth of the saw bent out of its plane by equal extent outwardly, in alternate manner.

To set a saw accurately, that is, to drive out each tooth the same distance, is the first requirement, and the second is to bend out the whole tooth, and not the point only.

The point is merely bent out, this is wrong (Fig). The right way is shown in Fig. The whole tooth is bent, showing the correct way of setting. If whole tooth is not bent and only point is bent, following problems will arise,

- i) If the point projects to one side, each point or tooth will dig into the wood, and produce tooth prints in the wood, which make a rough surface.
- ii) If there are inequalities in setting the teeth, the most exposed points will first wear out, and thereby cause saw deterioration.
- iii) A saw with the points sticking out causes a heavy, dragging cut, and means additional labour.

Fig. A shows a very simple setting block. The teeth cannot go wrong in setting.

In Fig. of block shown above B, should be a pair of wooden pegs, driven into the wooden block on each side of the metal piece. The teeth of the saw rest against the pegs so that they serve as a guide or a gage, and the teeth of the saw, therefore, project over the inclined part (B) of the metal block. Now, with an ordinary punch and a hammer, each alternate tooth may be driven down until it rests flat on the inclined face (A), so that it is impossible to set the teeth wrongly.

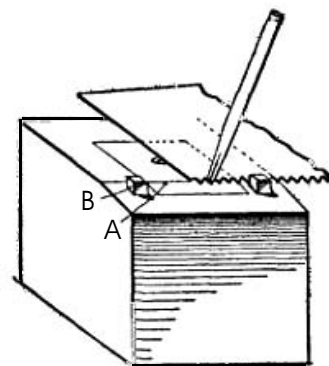

Setting Block

8.1.2 Filing Angles:

- a) In case of a Rip Saw the angle is 90 degree and Fig. shows an approximation to the right angle. The angle for Cross cut saw is about 12 degrees as shown in fig. marked A.
- b) Two things must be observed: the pitch and the angle. By pitch is

meant the inclination of the teeth. Fig. which shows the teeth of a rip saw. We will see at A that the pitch of the tooth is at right angles to the edge of the saw. In Fig. which shows the teeth of a cross-cut saw, the pitch (B) is about 12 degrees off. The teeth of the rip saw are also larger than those of the cross-cut.

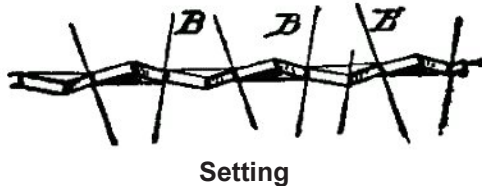

Setting

8.2 The Grind Stone:

As most of the tools require a grindstone for sharpening purposes, an illustration is given as a guide, with a diagram to show the proper grinding angle. In Fig., the upright of the frame serves as a line for the eye, so that if the point of the tool is brought to the sight line, and the tool held level, you will always be able to maintain the correct angle. There is no objection to providing a rest, for instance, like the cross bars, but many artisans do not prefer providing rest.

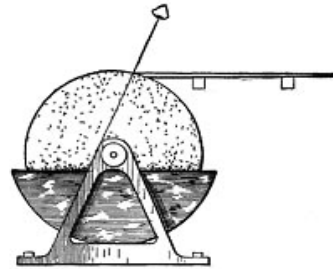

8.2.1 Don'ts:

- i) Never use one spot on the stone, however narrow the tool may be. Always move the tool from side to side.
- ii) Never grind a set of narrow tools successively. If you have chisels to grind intersperse their grinding with plane bits, hatchet or other broad cutting tools, so as to prevent the stone from having grooves therein.
- iii) Never use a tool on a stone unless you have water in the tray.

8.2.2 Correct Way to Hold Tool for Grinding:

There is a correct way to hold each tool (see Fig.). The left hand should grasp the tool firmly, near the sharp edge, as shown, and the right hand should loosely hold the tool behind the left hand. There is a reason for this which will be apparent after you grind a few tools. The firm grasp of the left hand gives you absolute control of the blade, so it cannot turn, and when inequalities appear in the grindstone, the rigid hold will prevent the blade from turning, and thus enable to correct the inequalities of the stone.

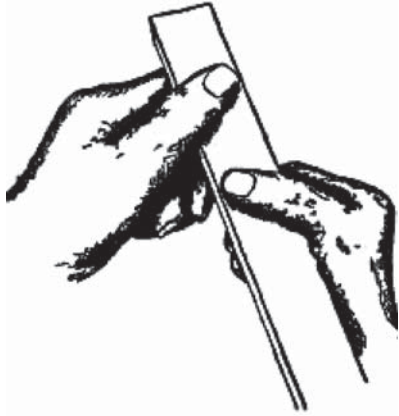
**Correct****Incorrect**

Incorrect Way to Hold Tool for Grinding.—The incorrect way of holding a tool is shown in Fig. It is wrong for the reason that the thumbs of both hands are on top of the blade, and they serve as pivots on which the tool may turn. The result is that the corners of the tool will dig into the stone to a greater or less degree, particularly if it has a narrow blade, like a chisel.

The left hand serves both as a vise and as a fulcrum, whereas the right hand controls the angle of the tool. Do not try to force the grinding. The stone should always move toward the tool, so as to prevent forming a feather edge. These apply to all chisels, plane bits and tools of that character.

Chapter 2

WOOD FOR CARPENTRY WORK

1.0 General

Wood has always taken a pride of place in Building construction and furnishing. However, the size and form of its usage has changed considerably over the years. From old days of Chettinad rosewood or Mahogany cabinet to the lightweight, sleek particle-board cabinets, wood has been through several transformations. The differing grains, colours, and expressions inherent in the material give wood a warm lively quality found in few other materials. Teak wood still rules the field and a favourite of builders, architects and users alike. There are several other species available in India, though large part is imported from neighboring countries, due to different types of controls and regulations against deforestation in our country.

2.0 Hard woods

Various hard woods available are

2.1 Teak:

This is the most commonly used hard wood for decorative purposes in India. Almost 80 per cent of all wood for decoration is teak. The price of teak, around Rs. 850/- per cubic feet, makes it a ubiquitous choice for users. It is used in cabinets, doors and frames. The advantage of teak is that it has high dimension stability, which prevents it from warping when exposed to different seasons, and it can resist termite attacks. It is suitable equally for indoor and outdoor use. The wood needs to be polished to bring out its natural sheen and look attractive. Teak is imported from Ivory Coast, and Africa as also available in Central parts of India like Nagpur and Madhya Pradesh, known as C.P. Teak. The African Teak is available at about Rs. 100/- per cft less than C.P. Teak or Ivory Coast Teak. This has a specific gravity of 0.63 when dry, though may vary in different species.

2.2 Rose Wood:

For furniture, it has beautiful grains, and is very stable and durable. However, as it is quite expensive and increasingly rare, it is not being used a lot these days.

2.3 Burma Teak:

It is probably the best and reminds one of old days when it was the common wood to be used even in Railway sleepers, beams, purlins and floors of buildings not to say for doors and windows. The high cost of the wood, around Rs.1,100 per cubic feet, makes it a hard to afford. Only very

few builders still recommend it. It is now being used only for decorative purposes.

2.4 Saal wood:

This is another common variety of hard wood used in building construction. This is strong wood and almost similar to Teak in mechanical properties but does not take good polish and is used for beams, purlins, and hidden wood work. This is still available in Eastern and North eastern parts of India but the old forests have practically all been cut and re- plantations only survives. The 'ballas' of saal are used for scantling and scaffolding works but for carpentry work the saal variety is mostly available from imports at about Rs. 500/- per cft.

2.5 Vengi Wood:

This is probably the most used wood in the construction industry. This hard wood is used extensively for doorframes, interior of sofas and any panelling. As there are no grains in the wood and because it presents a dull look when it is lacquered/polished, the Vengi wood at most times is painted. It costs around Rs. 700/- per cubic feet. The easy workability of the wood makes it quite popular in the construction industry, specially in South India.

2.6 Champ Wood:

This is found in Bengal and North Eastern India. This is good hard wood and has grains resembling Teak. However it does not take polish as well as Teak and has wider grain. It is used for construction of doors, windows and frames. This can be available in the range of Rs. 450/- to Rs. 650/- per cft. Furniture is also made from this wood in many parts of country.

2.7 Hollock Wood:

This is similar to Champ but is used for works requiring lesser and rougher finish and is cheaper than Champ, in the range of Rs. 350/- to Rs. 400/- per cft.

2.8 Merranti Wood : This is reddish yellow in colour. This is imported wood from Malaysia. This is about Rs. 500/- per cft. and is used for door window work.

2.9 Rajak Wood : This is in the same range as Hollock.

NOTE: The price of hard wood is indicative only for a comparison, and shall depend locally on several factors and market conditions

3.0 Soft wood:

Soft woods like Cedar, Pine, Fir, mango and deodar are not useful for Engineering requirements as they do not withstand wear and tear as also

mechanically weaker, for bearing load. These are generally used for packing cases, crates etc. However, these woods are used in manufacturing various boards plys etc. Places where wall paneling of solid wood is to be done, the soft wood planks can be used. These being soft woods, carving etc can be easily done and are preferred. These woods may have specific gravity ranging between 0.4 to 0.35, when dry. Balsa is the softest wood with specific gravity of 0.17 only.

4.0 Manufactured woods:

4.1 Plywood: Plywood is probably the most widely available manufactured board material. It is manufactured by pasting thin plys of natural wood, soft or hard wood or a combination of the two, with synthetic resins which are set and cured by heating. There is always an odd number of veneers/sheets and the direction of the grain runs alternately to give the material strength; the more veneers used, the stronger the ply board. Ply boards are dimensionally stable, however all ply boards unless properly supported will sag under load though gradually with time. It is easy to work with and can be finished using paint, the edges are required to be covered with a trim to hide the different layers. Both the type of glue and veneers determine the suitability of a sheet for a particular application. Commercial ply boards use water soluble adhesives and are not suitable for out door use. The finish quality of plywood varies enormously, some have attractive grains with decorative laminates or veneers while others can have a large number of knots.

4.1.1 Exterior grade plywood (WBP - Weather and Boil Proof) is specially made using a water-resistant adhesive to withstand a certain amount of moisture and can be used for outdoor constructions - sheds etc. and is sometimes used as a cladding material, particularly for insert panels under windows. WBP does require additional protection (paint or varnish) to protect the outer veneer.

4.1.2 Internal plywood is of a similar quality as Exterior grade but it does not use water resistant adhesive. It can be used for wall panelling, flooring and furniture.

4.1.3 Shuttering Ply is used in the construction industry for making shuttering boxes for containing concrete temporarily. Although water resistance to a degree, the sides of this material are not finished with a decorative veneer and is generally not suitable for use where a quality finish is required.

Marine Plywood is made with waterproof adhesive so that it will stand immersion in water, the veneers themselves will not last forever under water so the material should still be finished with paint or varnish.

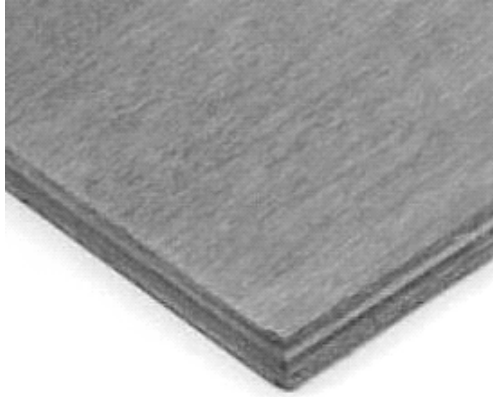

Plys can be seen on the cut edge

4.1.5 Plywood is normally available in 2440 x 1220 sheets (or subdivisions) and in thicknesses from 4 mm to 35 mm. The ply boards commercially are available in 4 mm, 6 mm, 8mm, 12mm, 19mm, and 25mm thickness. The price of water proof ply boards is about 10-20% more than commercial ply boards, depending upon the Brand and thickness of ply board. The rates are practically in proportion to thickness of the ply boards, which vary from Rs.190/- per sqm for 4mm ply to Rs.700/- per sqm for 25 mm ply for a branded material. Other products of lesser repute are available ranging between Rs. 110/- for 4mm and Rs. 530/- for 25 mm ply boards. Shuttering ply boards are normally of 12 mm thickness and should be of water proof quality.

4.2 Particle board

4.2.1 Plain Particle board: Unlaminated Particle board is the cheapest and weakest material. It is generally unsuitable for shelving or any structural purpose, further the finish is also poor. This is however used for wall paneling or false ceiling as it improves the acoustic character of the space. Particle board is made by bonding together wood particles with an adhesive under heat and pressure to form a rigid board with a relatively smooth



Flaky texture is visible at the cut edge

surface. Particle board is available in a number of densities; normal, medium and high-density. Normal density is fairly soft and 'flaky', high-density is very solid and hard (often used for tabletops and fire exit doors) - medium density is somewhere in between.

There are exterior grades of particle board available but most are only suitable for internal use as all but high-density tend to soak up water like a sponge. Once water logged, particle board tends to swell and breakdown.

4.2.2 Laminated Particle board: Laminated particle board is cheaper than solid timber and comes in a number of different types of veneer. It is not so strong as solid timber and will tend to sag except under a very light load. This is used for temporary shelf for exhibitions, fairs etc., partitions, panels etc. 12mm laminated thick particle board will support the shelf at no greater than 300mm centers for all but the lightest of loads, or 18mm particle board with supports no greater than 700mm apart. Some times this is also used for internal doors for mass housing schemes, with thickness of 25 mm. High-density particle board is often used as a basis for the shelves of kitchen furniture, table tops, and flooring - this is hardwearing, rigid and heavy.

4.2.3 Particle board is normally available in 2440 x 1220 sheets (or subdivisions), finished veneered sheets are available in smaller sheets so that the four decorated edges do not need to be cut. Thicknesses range from 9mm , 12 mm, 18 mm and 25mm. Interior particle board of 9mm costs approximately Rs. 175/- per sqm and of 25 mm thickness about Rs.350/- per sqm. The exterior use boards are appx. 10-20% costlier.



Particle board is sandwiched between laminates

Prelaminated particle boards are normally available laminated on one side at an additional cost of Rs. 100/- per sqm. The interior quality(OSD) of 9 mm being available at Rs.280/- per sqm and 25 mm at Rs. 450/- per sqm. The interior quality (BSD) of particle pre-laminated boards cost between Rs.308/- for 9 mm to Rs. 500/- per sqm.

4.3 Laminated softwood board (pine board etc) - made up of strips of softwood (typically 25 to 100mm wide) glued edge to edge, to achieve finished boards .This is typically as strong as solid timber of soft wood. These are used in flush doors for inside use. These can be worked with normal carpentry tools.



Strips of natural soft wood can be seen pasted along the grains

Boards are available in a number of thicknesses (15, 18, 25, 30mm), widths (400, 450, 500, 600 mm) and lengths (1.2m to 2.1m). This wide choice means that the appropriate sheets can be selected to suit the job while minimizing waste.

4.4 MDF (Medium Density Fibreboard):

MDF is stronger than Particle board and is easy to work with. MDF can be finished using paint to suit the decor or just sealed with a varnish. Use 18mm MDF as a minimum and support the shelf at no greater than 500mm centers for all but the lightest of loads. 25mm MDF board can be used for shelves, with supports no greater than 700mm apart. In India MDF is sold as NUWUD and is used in furniture making as well as flush or paneled doors. These boards are available in sizes 6mm, 8mm, 12mm, 18mm, 25mm, 30mm, and 35 mm. These are available in i) Furniture grade ii) Interior grade and iii) Exterior grade. For 18 mm thick size the cost of the three types is approximately Rs.395/-, Rs.485/- and Rs.600/- per sqm. respectively. MDF soaks water even from humid air and is not very stable in shape.

4.5 Block board:

Block board is composed of a core of softwood strips (up to about 25mm wide) placed edge to edge and sandwiched between veneers of hardwood, the 'sandwich' is then bonded under high pressure.

An interior grade adhesive is normally used, so block board is not suitable for use out of doors.

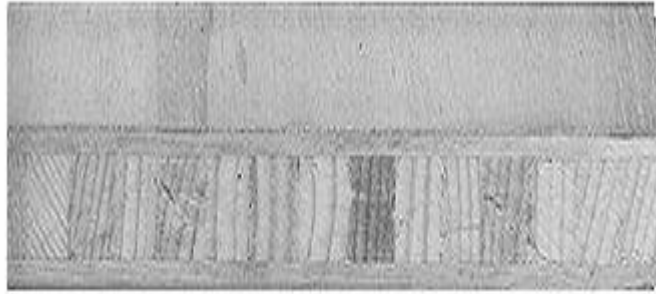

Core of soft wood strips can be seen at one of the cut edges

When using block board for such items as a door or a long table, make sure the core runs lengthways to give maximum strength. Block board can be used for shelves, doors, paneling and partitions (with the core running lengthways) is stronger than particle board and is less likely to sag. It is easy to work with and can be finished using paint, the edges will probably need to be covered with a trim to hide the different strips. Blockboard is normally available in 2440 x 1220 sheets (or subdivisions), thicknesses tend to be limited to around 25 mm.

4.6 Gypboard: Gypsum boards are used for false ceiling work and are available in tiles of 600x600 mm. They are marketed in 9.5 mm and 12 mm thicknesses. The plain board of 12 mm thick costs about Rs. 65/- per tile whereas patterned tiles of same thickness can cost Rs.145/- per tile.

5.0 Laminates: Laminated plastics are available in many colors, patterns and designs. They can be used for countertops, tabletops and many other surfacing applications.

The sheets are available in dull or gloss finish.

Laminated plastic is made from layers of paper that are first impregnated with resin and then bonded together under pressure and high temperature, forming a rigid sheet.

Decorative laminates like Formica, Sunmica, greenmica etc are available in thickness of 0.8 mm and 1.0 mm. These are available in sheets and cost approximately Rs. 500/- per sheet for 0.8 mm and Rs.750/- per sheet for 1.0 mm. These are water proof and pasted to the wooden surface with synthetic glues.

Note: The prices given are indicative only and may be substantially different depending on place and market conditions.

6.0 Timber - rotting problems:

Every house uses timber in its construction or decoration, and while it can last a long time, it is a dried material and nature has various methods of making it decay unless it is looked after. Providing it is well maintained, timber will last many life times. Below two areas of timber rot found normally are addressed - dry rot and wet rot.

6.1 Dry Rot:

Dry-rot fungus is often thought of as a building cancer, rampaging through buildings and rapidly destroying any timber in its path. The fungus, which thrives in moist unventilated conditions, will penetrate brickwork to get to more timber and can cause widespread destruction of structural timbers, skirting boards and door frames, and wood flooring.

In short, the fungus can be thought of as 'living in masonry and eating wood', and because the fungus thrives in damp, unventilated conditions, it can occur in the areas of a property that are not often seen, such as floor voids, or behind timber panelling, so damage may be extensive before the attack is discovered.

6.1.1 What to look for:

Initially the fungus appears as off-white felt-like or cotton-wool like sheets on brickwork and timber, and, in later stages, can develop fungal strands as thick as your finger. Where the fungus is exposed to light, it often has a lemon-yellowish tinge.

Damage is often confined to timber but large flat mushroom-like fruiting bodies can easily grow through finishes such as plaster or paint. These fruiting bodies may be the first visible sign of a problem, and they produce numerous spores which are normally brick-red in colour. Entirely dry-rot decayed timber can be crumbled between your fingers. The fungus leaves deep cracks running across the grain, and there is often evidence of off-white sheets of the fungus on the wood.

6.1.2 Treatment:

The term dry-rot came from the belief that the fungus is able to transport moisture from a source many metres away, to attack dry wood. In fact, although the fungus can transport moisture over several metres, it cannot transport anywhere near enough moisture to attack wood that is otherwise dry.

Treating dry-rot can involve removal of the affected timber (including all timber for a metre beyond the visible signs of the fungus), and extensive chemical fungicide treatments for all adjacent timber and the brickwork of any

contaminated walls and plaster. However, this approach is expensive and unnecessary.

The modern approach is to use environmental controls, such as isolation and ventilation, which ensure that the damp, unventilated conditions required by dry-rot do not occur. The techniques are simple ways to ensure that the timber in a property does not become damp enough for dry-rot to attack, for instance replacing dry-rot decayed joists with new timber using joist hangers, instead of building them back into the brickwork, or by using ventilated skirting board details to encourage ventilation of a floor void. Replacement door frames should have a strip of damp-proof membrane around the outside, to fully isolate them from damp or potentially damp brickwork, so the timber would never become damp enough for dry-rot to 'eat'.

If you have dry rot, it is probably best to have the problem looked at, and corrective action taken by a reputable specialist firm, so that you have a guarantee if the problems were to return.

6.2 Wet Rot:

Compared with dry rot, wet rot is hardly a problem. It is basically the timber decaying naturally in the presence of high levels of moisture. There is almost always a structural defect causing the problem, it may be that the wall adjacent to the timber is suffering from damp, or water collecting on the timber. Any structural problem must be tackled at the same time as the timber is treated otherwise the problem is likely to reoccur. The problem may just be damaged paint finish on the timber allowing the actual wood to absorb excessive moisture. Damage is normally limited to the timber although the original structural problem may also cause other areas to be affected by damp (such as plaster or just decorations).

6.2.1 What to look for:

Check vulnerable areas of timber, such as window and door frames, for signs of rot. The bottom of frames is more susceptible to rot where water can collect or the wall/floor is suffering from damp. If the paint finish is damaged, this can increase the risk of wet rot. However, although the paint may look sound, the timber underneath may be rotting from the back. You will often see a professional builder push a thin bladed knife into painted timber frames, the blade should stop after a very short distance; if it goes in up to the handle, it is almost certainly a sign of rot behind the paint. Timber suffering from wet rot will feel spongy (even through a coat of paint) and look darker than the surrounding timber. When dry, the timber will easily crack and crumble into fine particles. Timber in the roof can also be at risk especially where there is roof damage allowing rainwater to run onto the roof timbers.

6.2.2 Prevention:

Ensure that all external timber frames are adequately painted to protect the timber from frontal ingress of water.

Be aware of any damp walls and address the problem, it could be a missing/damaged damp proof course (dpc), a bridged dpc or a bridged cavity. If necessary seek expert advice as the symptom may be just a sign of a bigger problem.

Make sure that any soil and other debris is cleared away from around the bottom of timber frames.

Check the roof space for the ingress of water, you may not see daylight through a hole in the roof, the water could be running down the underfelt behind the tiles onto timber some distance away from the hole. When it is raining, go into the roof with a torch, the shining of water on a timber or felt normally stand out very easily.

Other favoured places for wet rot are under the kitchen sink, bath, shower, wash basins, toilet and behind the washing machine etc.; all areas where a small leak from either a water supply or drain could go unnoticed for a long time but where timber could become saturated with water.

6.2.3 Treatment:

First of all treat any structural problem, there is no point in repairing the damage to the timber if it is going to reappear.

If wet rot occurs in structural timbers (such as roof trusses, floor joists), expert advice should be sought as the implication for structural integrity must be established.

In other areas, the rotten timbers should be removed and replaced; if the damaged area is fairly small, it can be cut away and a new piece of timber joined to that remaining. If the damage is confined to a very small area, an epoxy based repair kit can be used to fill the damaged area once it has been cut back to sound timber and the new surface of the wood treated with a suitable primer. Preservative tablets are available which are inserted into the timber adjacent to the repaired area to protect the timber 'from within'. If there is any doubt that the structural problem has been eliminated, the new and adjoining timber should be treated with a proprietary wet rot treatment before redecorating.

After repair, external timbers should be protected with adequate coats of paint or some other suitable timber treatment/preservative.

Chapter 3

NAILS, HINGES AND FIXING MATERIAL

1.0 General:

1.1 Wood screws and Nails are a very important elements of Carpenter's need. A joint is strengthened by fixing it by fasteners, normally Wood Screws or Nails. The size of the members in any wood work not only depend on the load they are to carry directly but on their ability to join the members together. Joints not only should with stand the load but also remain stable in time and not give a odd appearance. It is therefore necessary to use the right fastener proper for each location, type of work and the requirement of the joint.

1.2 While, nail is very simple and easy to install by least skill and equipment required, it has some draw backs also. One of the important draw backs is that they can split the wood through which it is being driven since the action of driving a nail is by splitting it. Another shortcoming is that they can work out with the same ease with which they were driven and with use tend to show play in the joints, with time.

1.3 Wood screws are therefore to be preferred in all permanent construction in wood. They give a much rigid joint, there is no danger of splitting the wood, and do not work out easily. All furniture, doors and windows etc are jointed with wood screws only.

2.0 Nails:

Following are some of the types of nails used by carpenters,

- a) **Round wire nail** : These large round head nails are mostly used for rough carpentry where appearance is not important but strength is essential. They are inclined to split a piece of wood. Sizes from 20-150 mm (0.75in - 6in).
- b) **Oval wire nail**: Most suitable for joinery work where appearance is important since they can easily be punched below the surface. They are less likely to split the wood if driven in with the longer sides parallel to the grain. Sizes from 12-150 mm (0.5in - 6in)
- c) **Round or lost head nail**: Stronger than oval wire nails, they can easily be punched below the surface of the wood. Sizes from 12-150 mm (0.5-6in)
- d) **Tack**: A short nail with a wide, flat head, the tack is used for fixing carpets to floorboards and for stretching fabric on to wood.

- e) **Panel pin:** Round lightweight nail used for cabinet-making and for fixing small mouldings beads into place.
- f) **Cut floor brad:** Rectangular, they have an L-shaped head and are nearly always used for nailing floor boards to beams. Sizes from 25-150 mm (1-6in).
- g) **Masonry Nail:** Made of hardened steel, this nail is used to fix wood to brick, concrete block and most types of masonry.
- h) **Square twisted nail:** Twists into the wood. These comparatively expensive nails offer a more permanent, screw-like grip than plain nails.
- i) **Annular nail:** Useful where very strong joints are required. The sharp ridges round the shank become embedded in the wood to give a tight grip.
- j) **Cloot head nail:** Made of galvanized steel, with a large, flat retaining head, this nail is most suitable for soft materials such as plasterboard and roof felt.
- k) **Spring-head roofing nail:** For fixing corrugated sheeting to timber. The twisted shank and inverted cup head produces a very strong purchase.
- l) **Corrugated fastener:** For reinforcing a weak wood joint or for securing mitred or butt joints in rough framing.
- m) **Cut clasp nail:** Rectangular in section, they are difficult to remove and provide a very strong fixing in wood and pre-drilled masonry. Sizes from 25-150mm (1-6in).
- n) **Hardboard nail:** These have a diamond-shaped head which is virtually hidden when hammered into hardboard. Sizes from 9-38mm (3/8-1.5 in).
- o) **Sprig:** A small nail without a head. They are used mainly to hold glass in window frames before applying putty which covers them up. Sizes from 12-19mm (0.5-0.75in)
- p) **Upholstery nail:** Available in chrome, brass and other metallic finishes, they are used as a secondary fixing with tacks. The dome head gives a decorative finish when nailing chair coverings into place. Various head sizes are available.
- q) **Staple:** U-shaped round wire nails with two points to hold lengths of wire in position. Some staples have an insulation.

Nails: The appearances of different nails is shown below.



(a) Round Wire Nail



(b) Oval Wire Nail



(c) Round or lost head nail



(d) Tack



(e) Panel Pin



(f) Cut floor brad

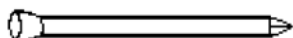

(g) Masonary Nail



(h) Square twisted nail



(i) Annular nail



(j) Cloat head nail



(k) Spring-head roofing nail



(l) Corrugated fastener



(m) Cut clasp nail



(n) Hard board nail



(o) Sprig



(p) Upholstery

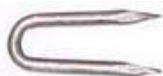

(q) Staple

2.1 The nails are designated with the length and nomenclature. The round wire nail is the most commonly used nail and their weight is given hereunder,

| inches | cm | Typical Wire nails per Kg |
|--------|--------|---------------------------|
| 1.00 | 2.540 | 1927 |
| 1.25 | 3.175 | 1251 |
| 1.50 | 3.810 | 694 |
| 1.75 | 4.445 | 595 |
| 2.00 | 5.080 | 396 |
| 2.25 | 5.715 | 352 |
| 2.50 | 6.350 | 231 |
| 2.75 | 6.985 | 209 |
| 3.00 | 7.620 | 154 |
| 3.25 | 8.255 | 143 |
| 3.50 | 8.890 | 110 |
| 4.00 | 10.160 | 66 |
| 4.50 | 11.430 | 55 |
| 5.00 | 12.700 | 37 |
| 5.50 | 13.970 | 33 |
| 6.00 | 15.240 | 22 |

2.2 Nailing Procedure:

- a) While joining two pieces of wood, specially planks or thin members, nails should be driven in inclined direction as shown below.
- b) After driving the nail into the wood, the nail head should be driven by a nail punch and hammer to give a good appearance.
- c) The hammer should be struck fair on the head of nail, any hit at an angle will bend the nail and also likely to cause injury to the

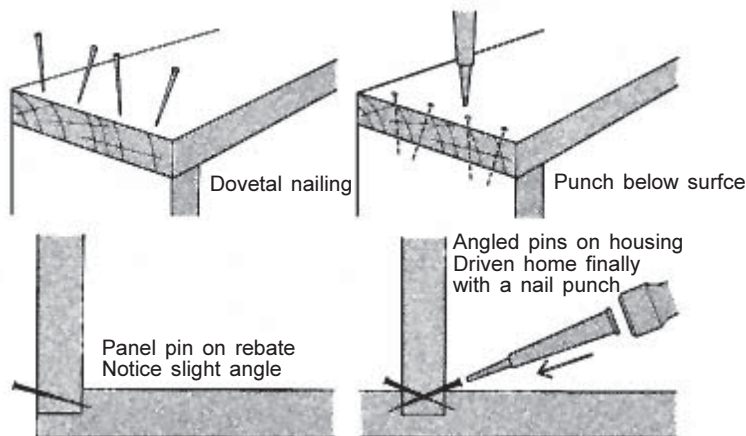

carpenter. Similarly while pulling out a nail with the help of the claw end or spincer, a piece of waste wood should be kept under the poll end of claw hammer and next to spincer toward the direction of pull. This is to protect spoiling of the job piece and also to assist pulling out nail.

- d) The length of the nail should be such that it reaches very near the other end of the 2nd piece. In case of joining a thin piece like plank to a beam etc. i.e. a big piece, the length of the nail should generally be three times the thickness of plank i.e. the thinner piece.

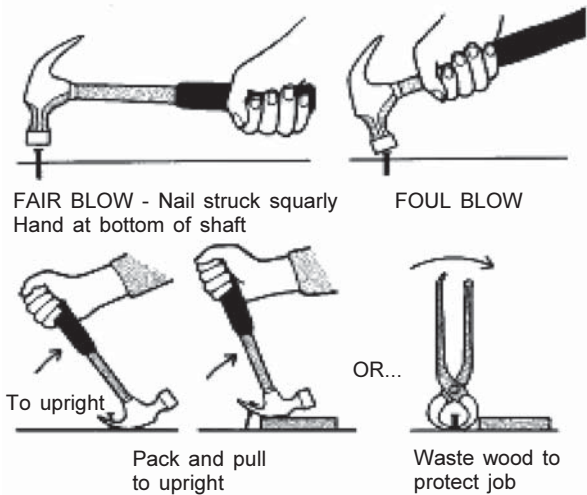

3.0 Wood Screws:

3.1 Mainly there are 3 types of wood screws used in carpentry work. Wood screws are classified by the type of drive, the shape of head.

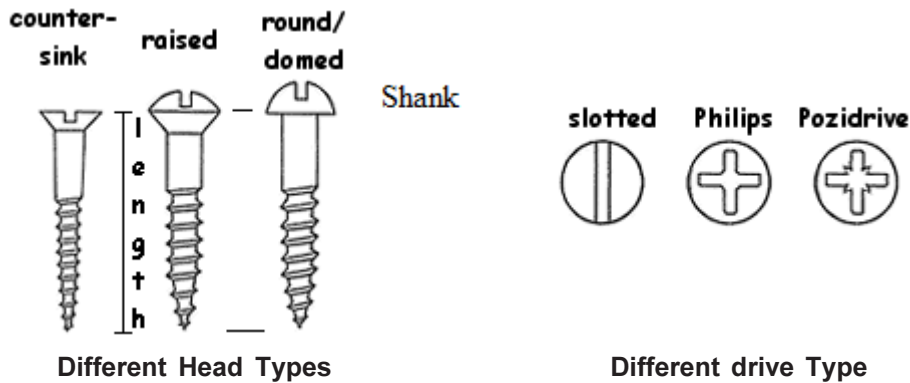

3.2 Threading on the shank is designed specifically for wood; wood threads have a tapered screw while sheet-metal screws have mainly a parallel thread. Wood type screws are also normally used for securing into wall plugs. Screws for particle board usually have 2 threads on the full length of the shank.

3.3 Types and uses

- a) Counter sunk Screws: The head is so designed that the head will be flush with the wood surface. These are the most commonly used screws. These are either slotted head or can also be Philips head. For Philips head the proper screw driver to be used is Philips Screw Driver, which has the bit designed to grip all 4 sides of the slots. Flat head screws fit into tapered recesses (such as the holes in hinges) and will be flush with the surface when properly applied.
- b) Raised head screw: These are counter sunk screws with slightly raised/oval heads. These are also used like counter sunk head screws but are protruding slightly in oval shape, for better appearance.
- c) Round head Screw: The head of the screw is rounded and protruding outside but flat at bottom. These are also available with through slotted head or Philips head. The rounded head is always visible, and is mostly used for fastening thin sheets or wood pieces and are also used where these may have to be un-screwed during service life of the wooden piece for replacement of one of the parts.

3.4 The screws are identified by their head, drive, length and shank diameter in gauge no. or in mms. Screws are sized by gauge number and length.

The table gives identification of some of the commonly used screws based on the above.

| Shank diameter | | Screw size Identification |
|----------------|------|---------------------------|
| Inches | mm | |
| 1/16 | 1.6 | 0 |
| 5/64 | 1.98 | 1 |
| 3/32 | 2.4 | 2 |
| 7/64 | 2.8 | 3,4 |
| 1/8 | 3.2 | 5 |
| 9/64 | 3.6 | 6 |
| 5/32 | 4.0 | 7,8 |
| 11/64 | 4.36 | 9 |
| 3/16 | 4.75 | 10 |
| 13/64 | 5.16 | 11 |
| 7/32 | 5.6 | 12 |
| 1/ 4 | 6.35 | 14 |
| 17/64 | 6.75 | 16 |
| 19/64 | 7.54 | 18 |
| 5/16 | 7.93 | 20 |
| 3/8 | 9.53 | 24 |

3.5 Also, when choosing screws for connecting two pieces of wood, choose a screw that is as long as possible without poking through the back side of the receiving piece of wood. This will help insure a strong connection without defacing the receiving piece.

3.6 Wood screws are usually made of hardened steel, but are also found in brass and stainless steel. Some may have galvanized coatings to help prevent corrosion. When using wood screws to affix two pieces of hardwood stock, be certain to pre-drill a pilot hole and countersunk. Failure to do so may cause the wood to crack, which will likely cause a big problem that you'll have to deal with. As the upper part of the shanks of wood screw are unthreaded, clearance holes should be drilled in the top piece of timber, this will allow the timber to be pulled tight onto the underlying surface. If the unthreaded shank is longer than the thickness of the top timber and the screw is larger than size 6 or the underlying timber is a hard wood, the clearance hole should be extended into the top of the underlying timber. Where the underlying timber is softwood and the screw size is less than size 6, a drilled pilot hole is not normally required; using a bradawl to mark the position is adequate. In other cases pilot holes are to be drilled in the receiving wood piece.

When using brass screws, always insert, tighten and remove a steel screw of the same size before fitting the brass screw - brass screws are relatively soft/weak and having used the steel screw to cut the thread will reduce the risk of damaging the brass screw. The recommended size of pilot and clearance holes are given in table below,

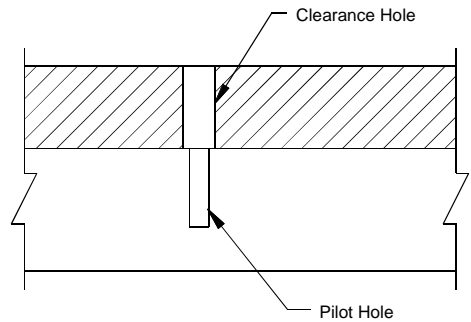

Clearance hole and Pilot hole

| Screw size | inch | | | mm | | |
|------------|----------------|-----------------------|-----------------------|----------------|-----------------------|-----------------------|
| | clearance hole | pilot hole (softwood) | pilot hole (hardwood) | clearance hole | pilot hole (softwood) | pilot hole (hardwood) |
| 0 | 1/16 | bradawl | 1/32 | 1.6 | bradawl | 0.8 |
| 1 | 5/64 | bradawl | 1/32 | 2.0 | bradawl | 0.8 |
| 2 | 3/32 | bradawl | 3/64 | 2.4 | bradawl | 1.2 |
| 3 | 7/64 | bradawl | 1/16 | 2.8 | bradawl | 1.6 |
| 4 | 7/64 | bradawl | 1/16 | 2.8 | bradawl | 1.6 |
| 5 | 1/8 | bradawl | 5/64 | 3.2 | bradawl | 2.0 |
| 6 | 9/64 | 1/16 | 5/64 | 3.6 | 1.6 | 2.0 |
| 7 | 5/32 | 1/16 | 3/32 | 4.0 | 1.6 | 2.4 |
| 8 | 11/64 | 5/64 | 3/32 | 4.5 | 2.0 | 2.4 |
| 9 | 3/16 | 5/64 | 7/64 | 5.0 | 2.0 | 2.8 |

| Screw size | inch | | | mm | | |
|------------|----------------|-----------------------|-----------------------|----------------|-----------------------|-----------------------|
| | clearance hole | pilot hole (softwood) | pilot hole (hardwood) | clearance hole | pilot hole (softwood) | pilot hole (hardwood) |
| 10 | 3/16 | 3/32 | 7/64 | 5.0 | 2.4 | 2.8 |
| 11 | 13/64 | 3/32 | 1/8 | 5.5 | 2.4 | 3.2 |
| 12 | 7/32 | 7/64 | 1/8 | 5.5 | 2.8 | 3.2 |
| 14 | 1/4 | 7/64 | 9/64 | 6.5 | 2.8 | 3.6 |
| 16 | 17/64 | 9/64 | 5/32 | 7.0 | 3.6 | 4.0 |
| 18 | 19/64 | 9/64 | 3/16 | 7.5 | 3.6 | 5.0 |
| 20 | 21/64 | 11/64 | 13/64 | 8.5 | 4.5 | 5.5 |
| 24 | 3/8 | 3/16 | 7/32 | 9.0 | 5.0 | 5.5 |

3.7 Driving a screw

3.7.1 Some do's and don'ts

Do's

- i) Always use the proper screw driver. For a slotted head, common screw driver be used with right size tip. Over size or under size tip can damage the screw head and the screw driver also. For Philips head screw driver only be used.

To drive a screw correctly the tip must fit.

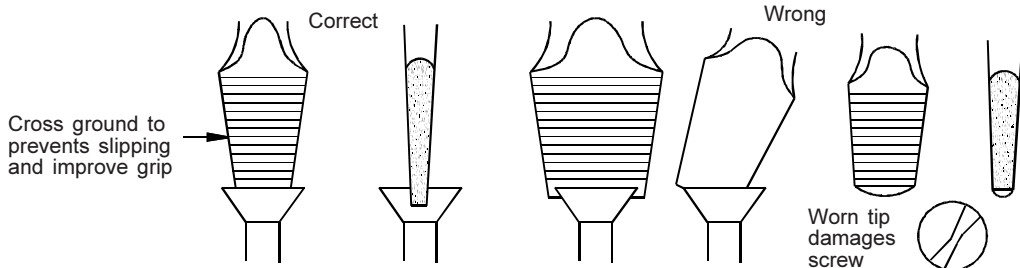

- ii) Driving a screw is a 2-hand job, and must be driven accordingly. Non-observance can, not only damage the screw but also cause body harm.
- iii) Screw must be screwed only after pilot holes and clearance holes are made.
- iv) All joints should be provided minimum 2 screws, less than 2 will allow rotation of joint.

Driving a screw is a two hand operation.

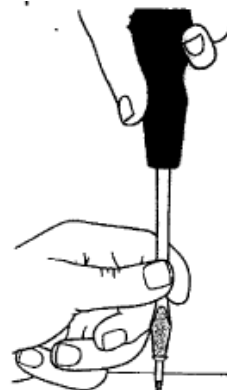

4.0 Hinges:

Hinges are used to connect the door, windows, covers etc to the frames. These are of several designs and types, mainly according to the

use they are required to be put to, Some of them are described below,

- a) **Butt hinges:** Butt hinges are probably the most common type of hinge found around the house to hinge two wooden parts. They are used on wooden internal and external doors, also on casement windows, various cupboards and other pieces of furniture.

The two halves need to be recessed into and traditionally the two halves are held together by a shaft through the centre of the spine - some modern ones use an arrangement of ball bearing and these type are recommended for heavy doors.

Different finishes are available and hinges are made from plain steel, brass, chrome, stainless steel and are available upto 150 mm length.

- b) **Security butt hinges:** Like ordinary butt hinges, they only suit wooden doors and need to be recessed into the surfaces.

If an ordinary butt hinge were used in this position, the hinge pin could be removed and the door released. With security butt hinges, the two halves of the hinge are lock together when the door is closed so removing the hinge pin won't allow access.

- c) **Rising butt hinges:** This type of hinges raise door 12mm to 16mm while opening the door to clear carpet or uneven floor. It prevents damage caused by scraping.

- d) **Flush hinges:** A lightweight hinge which has the advantage over a butt hinge that it fixed directly on to the surface without the need to cut a recess. These are usually used on cupboards.

- e) **Continuous hinges:** This type of hinges are used for high traffic doors i.e. high used doors. This type of hinges distribute the weight of the door

- f) **Concealed hinges:** Used to hinge cupboard doors so that they are not externally visible. Most types require a large hole (typically 35mm dia) in the door for the body to fit into.

- g) **Tee hinges:** Tee hinges are generally used on timber sheds or fencing gates etc where the long arm is fitted to the door and the narrow part to the door jamb. These are available normally upto 150 mm. They offer little security as the fixing screws are exposed.

- h) **Double action hinges:** It is used where door pannels need to fold in either direction.

- i) **Friction hinges:** Friction hinges are used on UPVC double glazing windows where no catch for securing the window is required.

Different manufactures of double glazing use different styles of friction hinge so care need to be used if these are purchased as replacements - i.e. they may not suit you particular windows.

Also, manufactured windows will often have the hinge riveted to the frame and casement, this makes removing the old hinges a problem.

- j) **Parliamentary hinges:** This type of hinges are used when the door panel is required to be away from the wall at open position. This hinges allow the door panel to swing back flat against wall.

Hinges:



a) Butt hinge



b) Security butt hinge



c) Rising Butt hinge



d) Continuous hinge



e) Flush hinge



f) Concealed hinge



g) Tee hinge



h) Double action hinge



i) Friction hinge

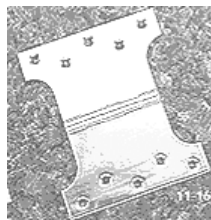

j) Parliamentary hinge

5.0 Tower bolt:

5.1 Tower bolts are a fitting to lock the door or window from inside. These are available in mild steel, black enamel coated, brass like (made of mild steel but coated to look like brass), brass, stainless steel and aluminium. These are fixed by means of wood screws. They are available commonly upto length of 300 mm. They are available in different styles with or without padlock arrangement. The common tower bolts are without padlock arrangement. Some styles are shown below.



a) Tower Bolt (75 mm to 250 mm)



b) Necked tower Bolt (100mm to 200mm)

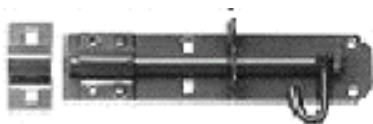

c) Medium Brenton Padlock Bolts (100mm to 300 mm)



d) Heavy Brenton Padlock Bolts (150 mm to 300mm)



e) Pad Bolt (100 mm to 200 mm)

6.0 Aldrops: Aldrops are stronger than bolts and are used commonly as a securing device for outside of the door. They all have a locking arrangement, though sometimes they are also fixed on the inside of the door. Aldrops are available in steel, brass, aluminium and also in stainless steel. Generally, they are manufactured in sizes from 200 mm to 400mm long.



7.0 Safety Hasps:

7.1 Safety hasps are normally fixed in small cabinets, drawers, cupboards, fly net or mosquito proof net doors of food storage larders. They are available from 25 mm to 50 mm.



8.0 Right angles and Tee's:

These are fixed to strengthen the joints in wood work, where the aesthetics is not of consideration, specially in soft wood joinery, as the nail or screw joints tend to become loose. These are also commonly used in joining wood members in trusses of sloping roofs.

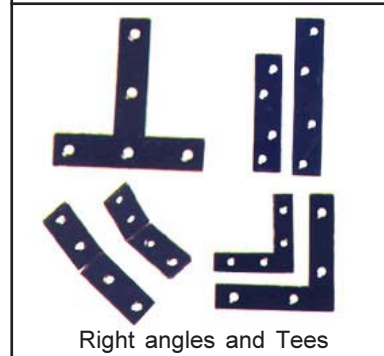

9.0 Door closers:

These normally function on hydraulic principles. There are variations in design in the mounting and the action they perform. The door closers are fixed to the surface of door, or on the floor and are known in the style they are fixed.



a) Surface Mounted Door Closer

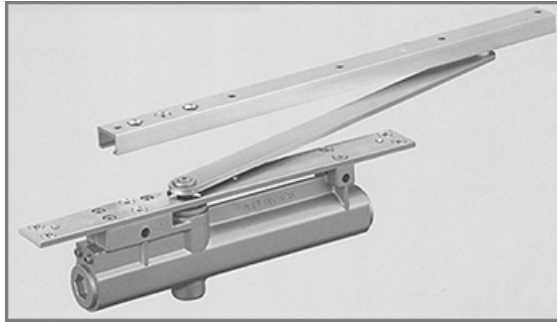

b) Concealed Type With Single Sliding Door Closer

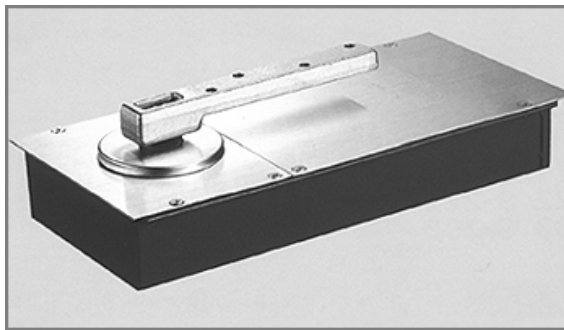

c) Floor Spring Floor Hinges for outward and inward movement

There are several kinds of fittings and fixtures available, for doors and windows and for almirahs, cabinets. Several types of knobs, handles, locks, stoppers, etc. It is not possible to describe them all here.

10.0 Sandpapers:

10.1 The term 'sandpaper' is used to cover abrasive grit on flexible backing sheets used to smooth many types of material. True 'sandpaper' (i.e. backing paper covered with grains of sand) is no longer available commercially but has been replaced by backing sheet covered with glass, aluminium oxide, silicon carbide, garnet or other specialist grit.

Each type of grit has different characteristics which make each most suitable for specific applications, an understanding of the types of grit is essential so that the right type is chosen for a particular job.

10.2 General characteristics:

10.2.1 Grit size:

Various sizes of grit are available for all types of grit material, the size is referred to by a number which represents the number of holes per linear inch in a sieve screen - they range from 40 (very coarse) to over 400 (very

fine). Good quality sandpaper will have universal sized grit. The size of grit is used to classify the sandpaper by 'grade' as follows:

| Grit size | grade |
|-------------|---------------|
| 40-60 | course |
| 80-100 | medium course |
| 120-150 | medium |
| 180-220 | fine |
| 240 upwards | very fine |

The individual sheets of sandpaper are normally marked on the reverse with the grit size (i.e. 120) and/or with the grade (i.e. medium).

10.2.2 Backing materials:

Three types of backing materials are commonly available:

- Ordinary paper - Although relatively a cheap backing, ordinary paper is an adequate material for most sandpapers. The quality of paper varies depending upon the intended method of use (and price); sandpaper supplied for use with power tools generally has a tougher quality of backing paper than that sold for hand use. Mostly for carpentry work, this type is used
- Waterproof paper - Water proof paper is essential where the sandpaper is to be used with a lubricant. The back of this type of paper usually has a darker, glossier appearance.
- Cloth - Generally used where a high degree of flexibility is required when using the sandpaper.

10.2.3 Backing adhesives:

Adhesives may be water soluble or waterproof. Most common sandpapers use a water-soluble adhesive; this is quite satisfactory, as most sandpapers are not intended for use with a lubricant.

Wet-and-dry sandpapers and others designed to be used with a lubricant, use a waterproof adhesive.

10.2.4 Forms:

Sandpaper is available in a number of forms, each form being available in a number of grades:

- Sheets - normally, about 280 x 230 mm, usually only suitable for hand sanding.
- Rolls - available in a number of widths (e.g. 50, 115mm), each roll is of a single grade and normally is sold by linear length. Although it is produced for use with power tools, it can be used for hand sanding.
- Sandpapers sold for power tool use are generally more robust than most types sold for hand sanding

10.2.5 Types of grit:

a) **Glasspaper**

Generally composed of quartz granules on a paper backing, this is an inexpensive, relatively soft abrasive for sanding painted or natural timber, metal, and other materials. It wears relatively quickly and is best suited to provide a rough finish before a really smooth surface is attempted.

b) **Aluminium Oxide**

This man-made material is suitable for shaping, sanding and polishing hard metal such as iron and steel, but also effective on timber. Aluminium oxide cuts much faster and lasts longer than glass or garnet.

It is available on non-waterproof, cloth or waterproof backings.

c) **Silicon Carbide (wet and dry)**

Silicon carbide paper, also known as 'wet and dry' paper, is suitable for both dry and wet sanding. It is suitable for sanding hardwood and plywood, soft metal like brass and aluminium, and plastic; also used for smoothing glass edges and frosting glass surfaces. It is fast-cutting and almost as hard as diamond, but it is brittle so the coarser grades will wear fast if used on hard metal.

d) **Garnet Paper**

This is a natural crushed rock and is an excellent abrasive for general wood sanding, either by hand or with a power tool - it is recognised by its distinctive bright green colour. The natural garnet grit lasts about twice as long as the quartz chips used on glass sandpaper but it is not as long lasting as Aluminium Oxide.

Garnet is also available with a cloth backing; in this form, it is used for work requiring more durability and flexibility.

Garnet Paper is a good all round abrasive, but particularly useful for smoothing hardwoods and for fine finishing work.

10.3 Using Sandpaper:

- Always use the correct type and grade of sandpaper for the job in hand - do not use paper sold for 'hand sanding' in a power tool.
- Start by using a medium or coarse grade paper. Change the grade of paper you are using as the job progresses.
- Let the abrasive grit do the work, do not use undue pressure it will only clog the paper or cause the paper to wear out unnecessarily quickly. When power sanding, very little pressure is necessary, just guiding the tool is normally sufficient.
- Use a sanding block when hand sanding.
- Move sandpaper along the grain of bare timber, not across.
- On a smooth, non-grained surface, move the sandpaper in small

circular motions.

- Store sandpapers carefully in a cool dry area. Except for papers made using waterproof adhesive and backing material, any dampness may cause the adhesive or backing to fail or weaken and grains will become detached.
- If the paper becomes clogged after a short time of use, look at the surface being sanded - if it is timber, the timber may be damp - allow time for it to dry out. Paint which clogs paper may either be too new to sand or old paint applied in thick coats which have not gone off.

11.0 Synthetic glues:

Mostly synthetic glues or adhesives are used these days. The properties are specified by name factor and printed on the cartoon. Before using the same should be consulted for proper use. Properties of some of synthetic glues are given here under:

| | PolyVinyl Acetate (PVA) like Fevicol MR | PolyVinyl Acetate (PVA) High Grade like Fevicol SH | Contact Cement like Fevicol SR | Epoxy glue like Fevittite | Polyurethane (PU) like Fevicol 1KPUR |
|---------------------|---|--|---|---|---|
| 1 | 2 | 3 | 4 | 5 | 6 |
| Applications | - low grade (craft or hobby glue); - edge- and face-gluing, bonding structural joints; - bonding plastic laminates etc; - can be coloured with dyes etc. | - high grade (professional/ industrial glue); - edge- and face-gluing, bonding structural joints; - bonding plastic laminates etc; - can be coloured with dyes etc. | - bonding plastic laminates; - decorative overlays; - other rigid sheet materials; - some modern water-based cements are fast drying and give high performance; - applying significant pressure to the work greatly increases the strength of the bond. | - waterproof exterior timber; - marine wood bonding; - bent laminating and veneering; - sealing; - topcoating; - casting; - embedding | - water-resistant exterior wood bonding; - laminating and veneering; - bonding nonwood materials; - develops full strength only in well-fit, tightly clamped joints; - modern formulas cure faster than the older ones. |

NAILS, HINGES AND FIXING MATERIAL

| 1 | 2 | 3 | 4 | 5 | 6 |
|---------------------------------|--|---|--|---|---|
| Availability/ using | ready to use; | ready to use; | ready to use use | - 2 part (resin and hardener); - can be coloured with specialty epoxy tints. | - ready to use; - work can be moistened before applications to speed hardening; - to prolong shelf life, squeeze air out of bottle, keep tightly capped and keep away from moisture and humidity. |
| Typical working time # | 5 to 30 min | 5 to 30 min | dry prior to assembly; open drying times: 10 to 20 min (water based), 2 to 15 min (solvent based), | 2 mins to 2 hrs plus | 10 to 40 mins |
| Clamp time # | 20 to 90 min | 20 to 90 min | 1 to 5 min will increase bond strength | 4 mins to 48 hrs | 45 mins to 10 hrs |
| Cured working properties | - fairly soft and workable; - can be cut with hand tools, machines well but loads paper when sanded; - reversible with water for 2 to 6 weeks after curing; - resist stains and finishes. | - cures hard; - can be cut with hand tools, machines well but loads paper when sanded; - can be softened or reactivated with heat up to several days after application; - not reversible with water after curing; - resist stains and finishes. | - soft and elastic; - can be machined and sanded but will gum up cutting edges and sandpaper; - may be softened by solvents (may be affected by solvents in stains and finishes. | - hard; - can be cut with hand tools if warmed; - machines and sands well; doesn't dull cutting edges as quickly as urea resin glue; - resists stains and finishes | - cured foamout is soft and cuts easily with hand tools; - machines and sands well; - compatible with most stains and finishes |

NAILS, HINGES AND FIXING MATERIAL

| 1 | 2 | 3 | 4 | 5 | 6 |
|----------------------------|---|--|---|--|---|
| Cured properties | <ul style="list-style-type: none"> - adequate strength; - low rigidity and creep resistance; | <ul style="list-style-type: none"> - greater strength, rigidity, creep resistance and durability than white PVA. | <ul style="list-style-type: none"> - initially very weak; - develops increased strength when pressed into thin layer; - no rigidity; - little or no creep resistance. | <ul style="list-style-type: none"> excellent combination of strength, rigidity, creep resistance and durability. | <ul style="list-style-type: none"> - good strength, rigidity, creep resistance and durability; - fills gaps but only with foamed glue (which has no structural strength). |
| Longterm properties | <ul style="list-style-type: none"> - low to moderate resistance to heat, moisture, acids and solvents and good shock resistance; - will gradually degrade if exposed to UV light. | <ul style="list-style-type: none"> - greater resistance to heat, moisture, acids and solvents and very good shock resistance; - will gradually degrade if exposed to UV light. | <ul style="list-style-type: none"> - good to excellent heat resistance if pressed into thin layer; - poor to fair moisture resistance if subjected to prolonged exposure; - poor solvent resistance. | <ul style="list-style-type: none"> - waterproof; can be weakened, broken down by some solvents; - fair to adequate heat resistance; - superior shock resistance; - may gradually degrade if exposed to UV light. | <ul style="list-style-type: none"> - excellent moisture, solvent and shock resistance; - superior heat resistance; - not completely waterproof. |

Chapter 4**WOODWORK JOINTS****1.0 Mortise and tenon joints:**

Mortise and tenon joints of different varieties are standard method of joining two pieces of Wood when 'L', 'X' or 'T' joints are to be formed. One piece is given a rectangular slot (Female), known as mortise and other piece is given a projected male end to fit the rectangular slot, known as tenon. Tenon is formed by cutting out $5/16^{\text{th}}$ width of the wood piece from both sides of the batten up to a specified length and keeping $3/8^{\text{th}}$ width of piece intact (depending upon the extent to which it is to penetrate the mortise of the corresponding piece). Similarly the mortise is formed by chiseling out $3/8^{\text{th}}$ width of the piece or equal to the width of the tenon, to a specified length (depending upon the extent to which the tenon is to penetrate and to be accommodated). In some joints an additional key is provided, also known as haunch on top/bottom side. The joint formed by fitting the two is called a 'Mortise and tennon' joint. The various joints are described from (a) to (k) in following paras.

1.1 Halved Joints:

There are simpler joints but strengthened with wood screws, like halved joints and mitre joints. Here the end to be joined is cut at 45 degrees, for half the width of the piece, and a matching cut on the corresponding piece. Various joints 'L', 'X' or 'T' can be formed by these joints also. The draw back in these joints is that these are eccentric to the point of application of load, in case of vertical door/window frames and are liable to show weakness under specific load conditions and are therefore not used. These are however used in packing cases, picture frames etc.

2.0 Commonly used Mortise and Tenon Joints are described below,

(a) Through haunched Mortise & Tenon

The length of the tenon is equal to the width of the other piece to be joined, such that the tenon fully pierces the mortise and gets exposed on the other end, and is called a through 'M&T' joint. Additionally a haunch is provided at the top and is called 'Through Mortise and Tenon Joint' The purpose of the haunch is to prevent the joint becoming 'bridled' as it reduces the tendency of the tenon cupping and thus avoiding the frame joint lose the right angle, after some usage. These types of joints are commonly used for door/ window frames and for paneled doors/windows. (Fig.a)

(b) Secret haunched Mortise and Tenon.

This is similar to the through haunched 'M&T' joint except that the secret haunch is achieved by cutting it at 45 degrees. This is needed for instance when the top of the frame is exposed such as a cane seat on a stool, etc. This is normally used in furniture work and not used in building doors/windows. (Fig. b)

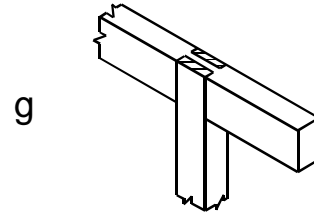
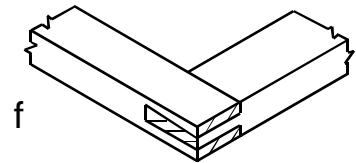
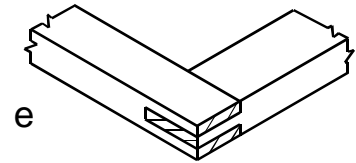
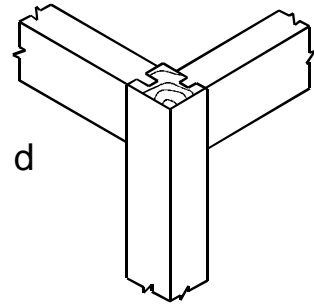
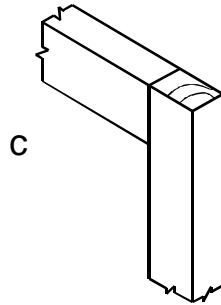
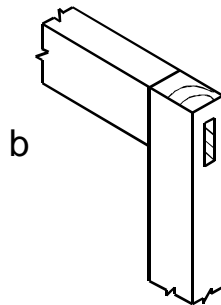
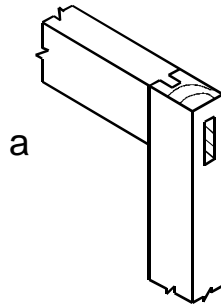
**(c) Secret Haunched Stub Mortise and Tenon**

Here the length of the mortise is less than the width of the piece receiving it in the Mortise. Similarly the mortise is not chiseled through, thus the end grain of the tenon is hidden and not coming through. Here also a haunch is provided which is not visible. It is prudent in all cabinet work to have a small shoulder top and bottom of say 2 to 3 mm to hide any 'blemishes' that may be exposed on cutting the mortise. (Fig. c)

Mortise and Tenon Joints**(d) Corner rail to leg**

This joint is used in joining the leg of a chair, stool or table. The M & T joint is a variation of c) above but in three dimensions. The meeting tenons are mitred to gain the maximum length. Note that it is also 'haunched' to prevent the joint becoming 'bridled'. A lower rail batten would not need the haunch. (Fig.d)

(e) Corner or 'L' bridle

Here both the mortise and tenon are cut through and jointed. This is comparatively a weaker joint and adopted for light use furniture and crude work. (Fig.e)

(f) Corner or 'L' dovetailed bridle

This is similar to above but stronger due to dovetail joint. Some chair seat are done like this. (Fig. f)

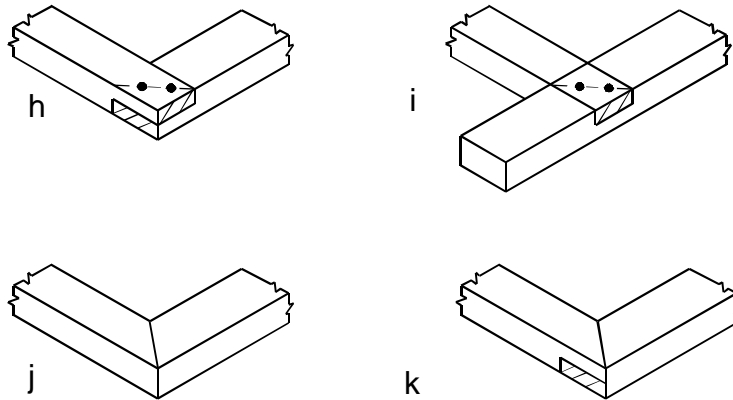
(g) 'T' Bridle

This is very commonly used for joining Stile of door/window to mid-rail in case of paneled doors, glazed doors, or even wire net doors. The mid leg in a half round table jointed like this. (Fig. g)

3.0 Halved and Mitre Joints

- (a) Corner halved or 'L' joint.** With countersunk screws to reinforce it. It is used for packing cases, carcasses quality work, etc. (Fig. h)
- (b) 'T' Halved Joint:** for a 'T' joint required in packing cases etc. this joint is used. The cut is made at 45 degrees in both the pieces, for half the width, matching each other. This joint can also be prepared for 'X' joint, where both pieces of battens can be continued. (Fig. i)
- (c) Mitred corner joint:** Both the pieces are cut at 45 degrees for full depth, and joined with glue and wood screws. This joint hides end grain, suitable for table top mouldings and picture frames, etc. where very less loads may be required to be taken by the joint. (Fig. j)
- (d) Halved corner Mitre Joint:** One piece is cut for half width at 45 degrees and the other piece is cut through at 45 degrees but half width is retained to join with the other piece. This is used where the

end grain may be hidden joint on atleast one face. This is stronger than Simple Mitre joint. (Fig. k)

4.0 Other types of 'T' Joints

- (a) **Butt joint:** Here the two pieces are often nailed with round headed nails from the horizontal batten, in a 'dovetail' fashion. This is called 'skew' or 'tosh' nailing. This is a very Low quality carpentry and is only used for temporary work like shuttering etc. (Fig. l)

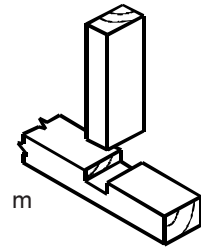
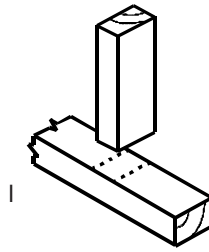

- (b) **Square through housing:** Somewhat better than (l) above. Often strengthened with nails as above. (Fig. m)

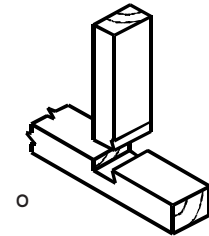
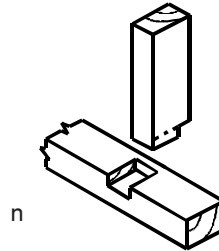

- (c) **Stopped Housing:** The stop or 'lap' is to give a better view. (Fig. n)

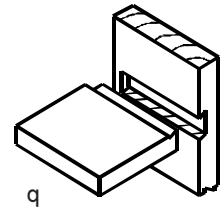
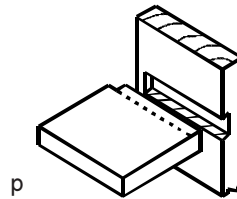

- (d) **Dovetailed housing:** To increase the strength of the joint in pulling dovetail joint is provided. This joint also has to be strengthened with nails or screws. (Fig. o)
- (e) **Stopped or 'lapped' housing or 'dado':** This joint is a variation of (n) for fixing planks, shelving or partitions, etc. It may be vertical or horizontal. (Fig. p)
- (f) **Stopped or 'lapped' dovetailed (single or double) housing or 'dado':** This is a variation of (o) for fixing of planks etc. and has greater strength in pulling. It is also to be strengthened with wood screws, nails. (Fig. q)

5.0 Splice Joints

These are used to extend the members, mainly thin members like

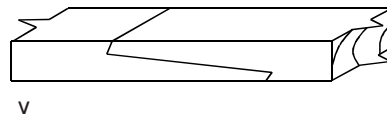
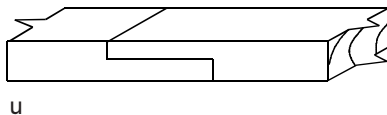

planks or scantlings where the joint would be hidden under lamination. The joint in fig. (v) is stronger than in fig. (u) as it provides more surface area for gluing.

6.0 Procedure for Correct Wood Working (Making a frame)

- i) The drawing supplied will be finished dimensions. Prepare an estimate of the material required based on the cutting lengths and the other dimensions like width and thickness also should have tolerance for planing etc. Cutting lengths are obtained by adding the sawing allowance (3-4 mm for every cut) but something additional which would be required to be cut at the time of fitting the joints.

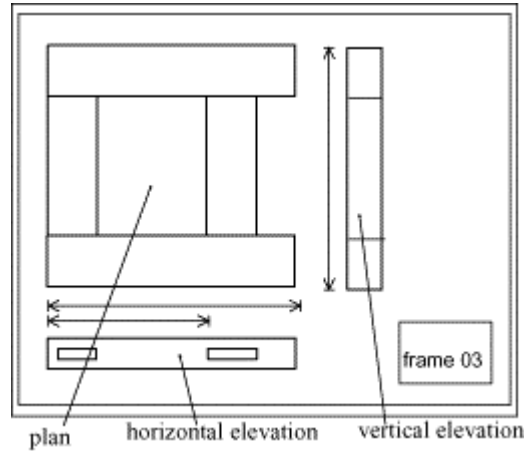

- ii) Do not mark out all individual lengths on the length of timber and then cut off like onion slices or like sausage. Measure, mark and cut off individually otherwise you will get a cumulative error. When you have cut out the members from the dimensions given in the Cutting List, lay out the members in the same arrangements as their positions shown in the scaled drawing. Always position the members in this way whenever you need to consider the next move. It helps to 'see' what you need to do next.

Don't mark out in a row and then cut off like sausages or you may well get a cumulative error

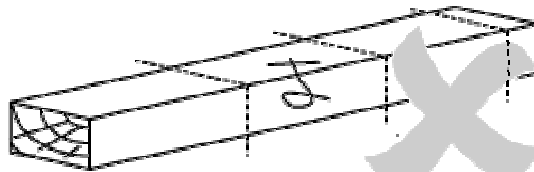

Measure each component individually, square at least the Face and an Edge, then cut off carefully with a Tenon Saw. Then repeat with the remaining pieces.

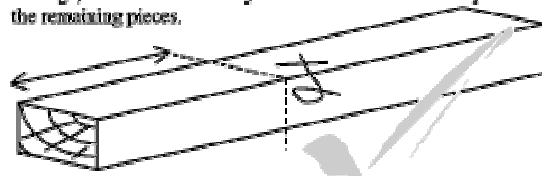

A 'Face mark' is drawn on the width of the wood in the direction of the 'Face edge' which is drawn on the corresponding edge of the member, and is drawn as a large 'X'. Use a HB pencil to draw details such as this. The Face and Edge Mark is very important and is always used to measure, mark and work from.

iii) The Horizontal and Vertical members are now brought together and clamped or held in the vice so that the dimensions and joint positions may be marked as one, on all similar members.

iv) From the Scaled drawing or Rod, determine the joint positions and mark these on the face edge while the members are still held together in the vice or clamps.

The actual line of the joint, where it is cut or joins is called the shoulder line. Always measure from the same point, say top or left of the frame. Use a marking knife or at least a sharp H2 pencil to draw shoulder lines. It is good practice to use the jointing member itself to determine the width and not a ruler or scale. First of all make a small mark to transfer the measurement and then with carpenters' square, complete the shoulder line across all the members so they are marked the same.

v) When all members have been treated in this way, remove from clamp, and taking each member in turn, with the carpenters' square, complete the 'squaring' all round. Take care to ensure that the stock of the square is always against either a face mark or face edge mark or the 'square' may not meet.

vi) Now that all members are marked or 'set-out', arrange the timber in the manner of the complete frame and identify each joint with a 'figure or 'letter' so you may re-construct the frame in the same position from time to time for checking. Note that the 'waste' area has been *neatly* 'hatched' with a HB pencil.

vii) Check that the lay-out and dimensions are the same as the drawing. After marking out all the pieces, the members shall look as seen below:

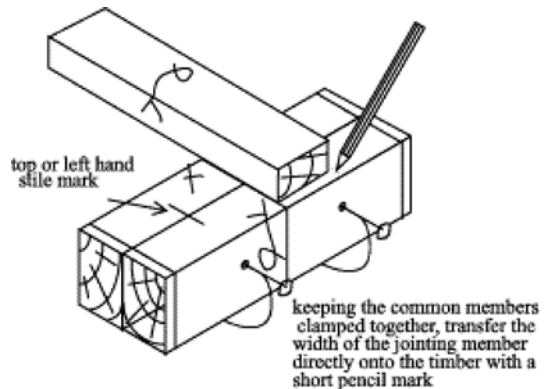
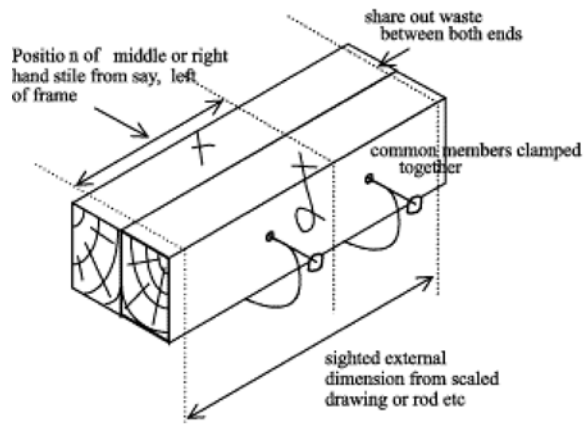

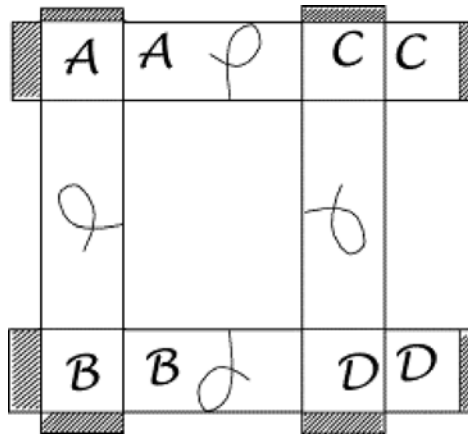

- viii) Next step is to gauge the width of the mortise and tenons. The thickness of the tenons should be approx. $\frac{3}{8}$ th of the width of the material to be jointed (some carpenters take $\frac{1}{3}$ rd the width, but $\frac{3}{8}$ th is stronger and should be adopted). From this select the nearest mortise chisel to this size.

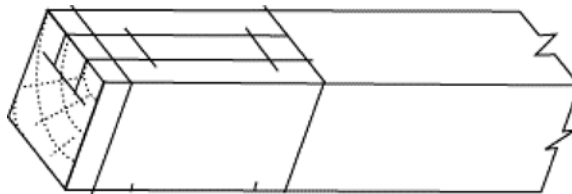

- ix) Take your Mortise Gauge to the Chisel you have selected and set the points as close to the thickness of the chisel as you can determine. If you cannot get gauge to exact chisel width then edge slightly on the smaller size rather than larger. This way the tenon will fit inside the mortise. If the tenon is gauged slightly larger it will not fit at all or will be too tight and need trimming. The joint should be loose enough to adjust and fit without driving all the adhesive out. If the joint has to be hammered home, it is too tight. On the other hand it should not be so loose to allow excessive movement away from its original shoulder positions. Most good adhesives will easily 'gap-fill' up to say 1 to $1\frac{1}{2}$ mm's.
- x) To use the gauge you should hold the timber firmly in your hand or in a vice. The gauge should be forced against the face side with the points of the gauge 'trailing' in order that they should not 'dig-in'. Do not press too deep at first otherwise the points tend to follow the

grain of the timber and it will be difficult to gauge a straight line. Better to make two or three attempts until you reach the right amount of depth. A sharp pencil following the scribed lines will improve the sighting.

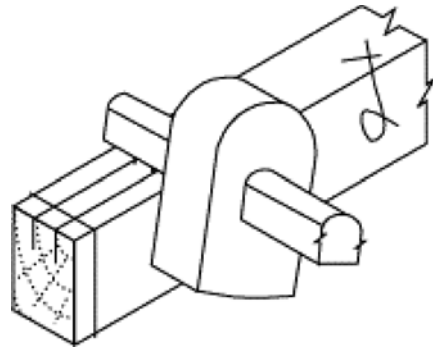

- xi) Scribe the mortise and tenon gauge lines between the full shoulder lengths and where there is a corner joint, all the way through the waste area to the end.
- xii) Where, on the corner joint there is to be a 'haunch' continues the scribed lines down to the depth of the haunch, say 12 - 15 mm down. The exact amount can be marked across in the next stage. Remember, failing to haunch a corner mortise and tenon causes the joint to 'break-out' and the joint is then 'open' or 'bridled'. Remember to scribe both edges and to keep the stock of the gauge always against the 'face mark' otherwise a 'step' will occur in the joint and cause 'winding'.
- xiii) Tenons are scribed between the full shoulder lines and down the end grain to meet with the other side. This allows you to saw down the end grain with a tenon saw.
- xiv) Treat all members similarly with the gauge and when complete return the gauge to the tool box. Place all timbers in their positions and then consider the next stage.
- xv) The joints at the corners that are to be haunched are diminished (made smaller) across the face edge and opposite side. Avoid where possible marking across the face (other than the shoulder lines) because it can create confusion.
- xvi) The mortise should also be 'cut-back' on the inside of the joint where a groove or rebate reduces the width of the tenon.

7.0 The working and making joints:

The working and making of a i) Shoulder ii) M&T joints iii) 'T' and 'X' joints in frame iv) 'T' and 'X' joints in planks v) Simple and dovetailed joints in planks explained in the steps through sketches given below.

7.1 Cutting and cleaning a Shoulder:- The shoulder is a vertical cut in the wood to accommodate another piece of wood. The shoulder in different job conditions is shown in sketch below. The other steps for making a shoulder are a) Sawing a shoulder b) Smoothing or cleaning the shoulder.

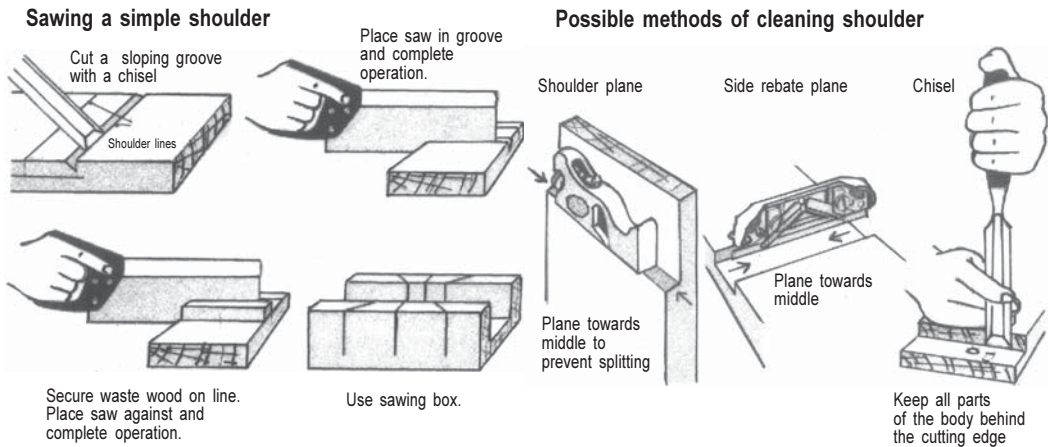
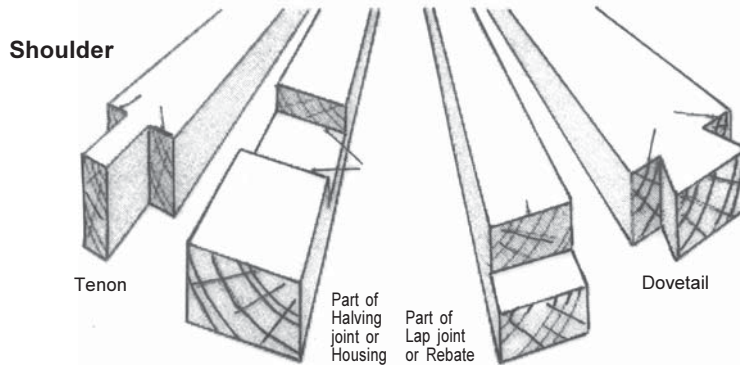

7.2 Mortise and Tenon Joint:

Normally the horizontal member is made the tenon (Male part) and the vertical member the Mortise (Female part). The making of Tenon requires sawing of the tenon cheeks in 3 steps a) sawing at 45° from side 1, holding the piece angular in vice b) sawing at 45° from side 2, holding the piece angular in vice and c) sawing horizontally down to shoulder. Then the tenon width is sawn and followed by sawing of shoulders and haunch if provided. The shoulder should be cleaned using special plane or by chisel.

Next the Mortise is cut using Mortise chisel in steps taking little material at a time or the work can be also started by boring/ auguring holes of required depth and later giving it the required shape and size by chisel. Haunch is cut the last, wherever required as shown in sketches below.

Cutting the Mortise

Remove waste by chiselling

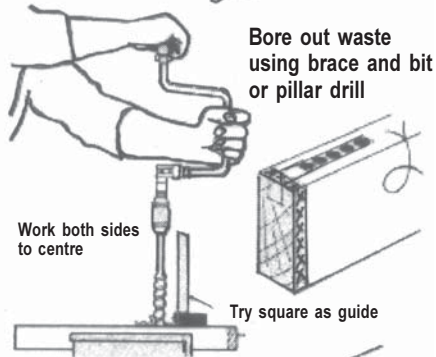
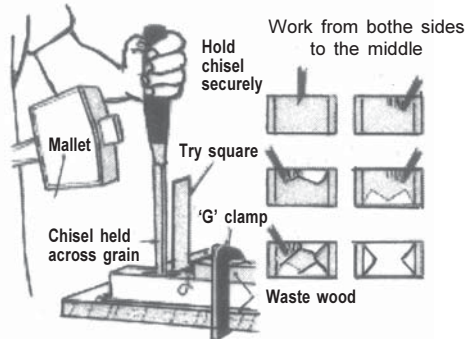

Clean out haunch

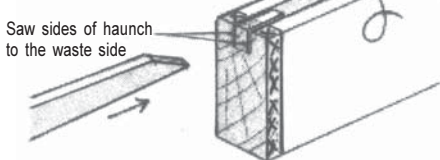

Cutting the Tenon-Sawing procedure

Saw cheeks

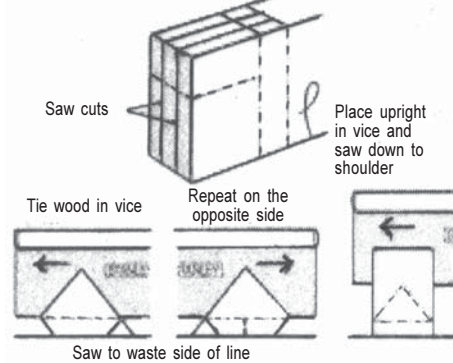

Saw width of Tenon

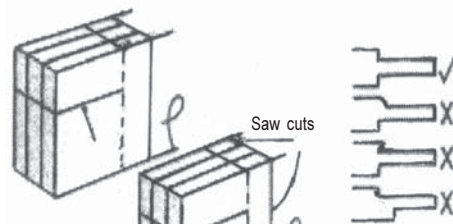

Saw shoulders

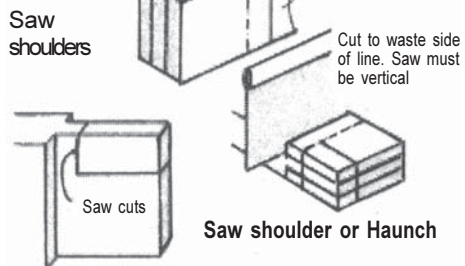

7.3 'T' and 'X' joints in frame:- 'T' and 'X' joints are very often used for frames and the method for making of both is similar. In 'T' joint there is one socket and 1 pin to be joined and in 'X' joint two sockets is to be joined.

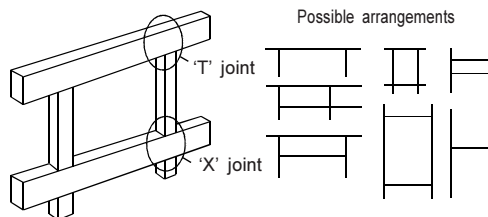

Procedure for making a 'T'- Halving

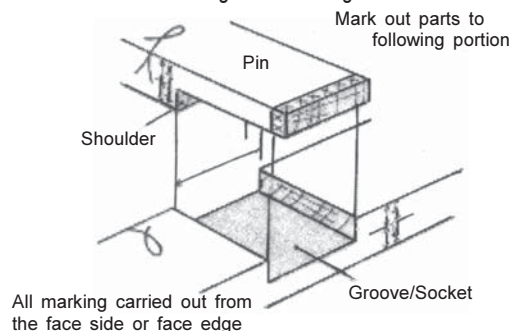

Shoulders are prepared in the standard way as explained in para 7.1 and the detailed procedure is explained in steps through sketch as below.

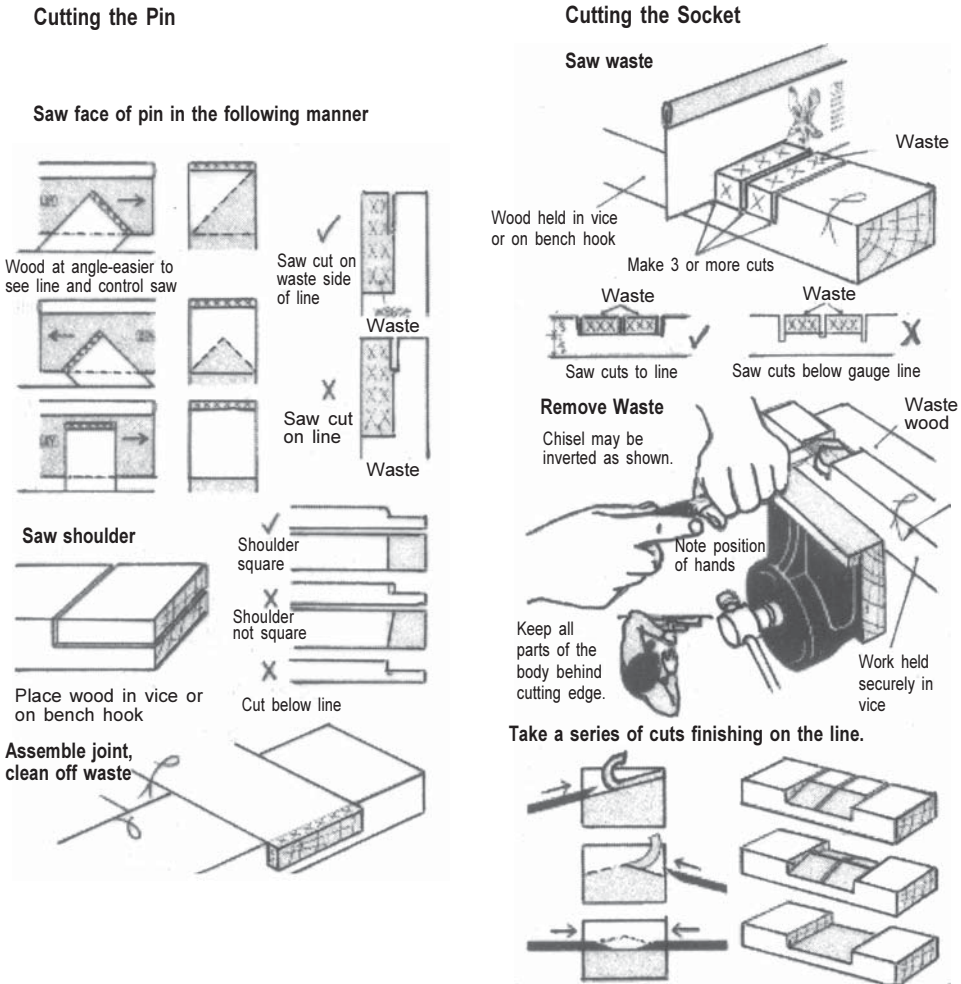

7.4 'T' and 'X' joints in Planks:- Shelf and cabinet work is normally done using planks and 'T' and 'X' joints are used for joining just like similar joints for frames. The difference is that joints in planks have to be longer and elaborate to gain enough strength for carrying loads. Simple joint are, i) Escaped bare face dovetailed housing ii) Through housing iii) Stopped common housing iv) Stopped housing with through twin tenons and v) Butt glued dowelled joint. Commonly used are Through housing for general work and stopped common housing joints for aesthetic work. The making of stopped common housing is explained in steps through sketch.

Simple 'T' and 'X' Joints

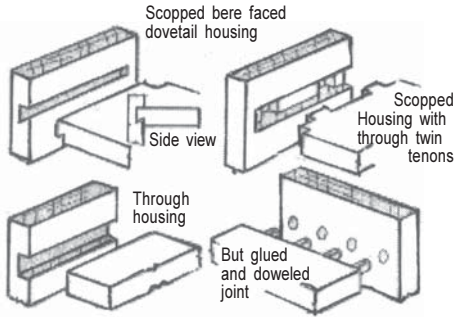

Procedure for making a stopped common housing joint

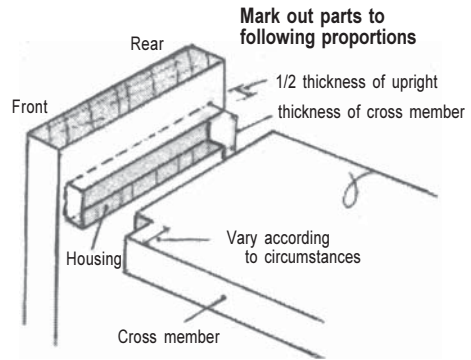

Cutting the Housing

Chisel out recess

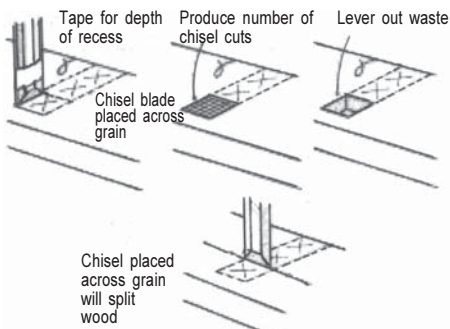

Saw down sides of housing

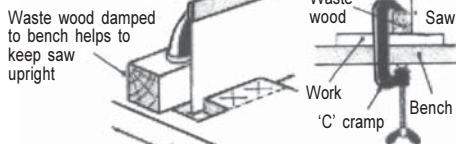

Chisel out waste

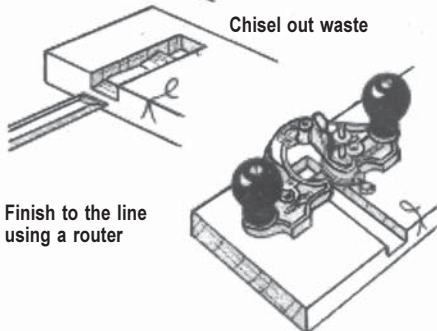

Saw off waste on cross meter

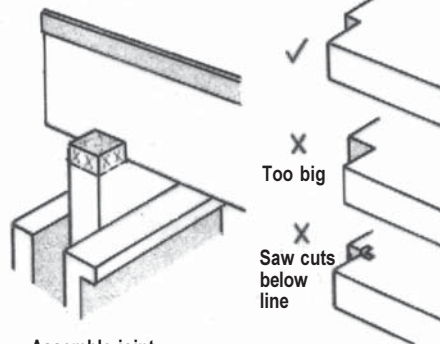

Assemble joint

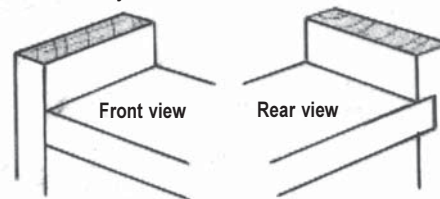

If joint is too tight shave off shoulder of housing with side rebate plane.

Nose removed to allow access into stopped housing

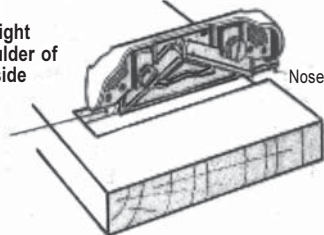

7.5 Simple 'L' joints:- The Simple 'L' joints in planks can be i) Butt glued and nailed ii) Lap glued and nailed iii) Finger or Box joint iv) through dovetail joint and v) Lap dovetail joint. The strongest and aesthetic joint is dovetailed joint and the steps for making a through dovetailed joint is explained through sketch below.

Simple 'L' joints

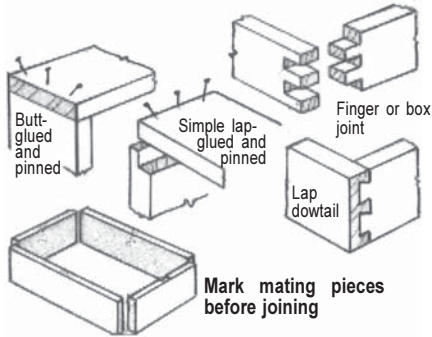

Mark out parts to following proportions

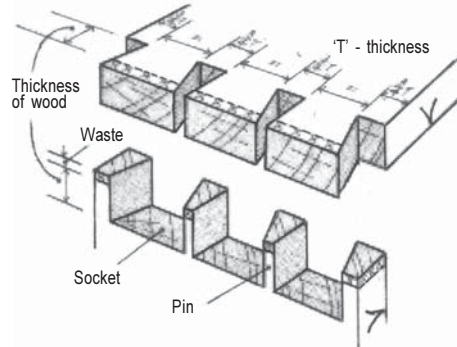

Setting a bevel to a slope 1:6

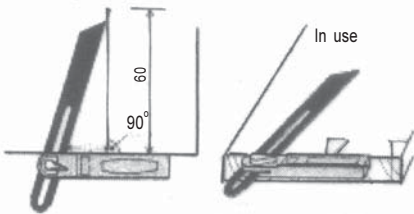

Cutting the pins

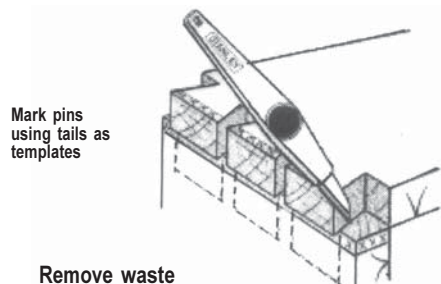

Cutting the tails

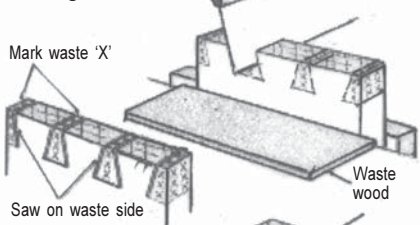

Remove waste

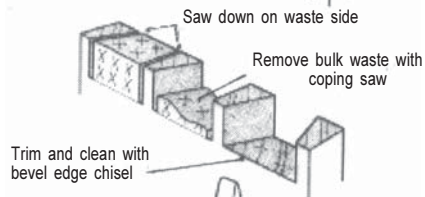

Remove bulk waste with coping saw or chisel

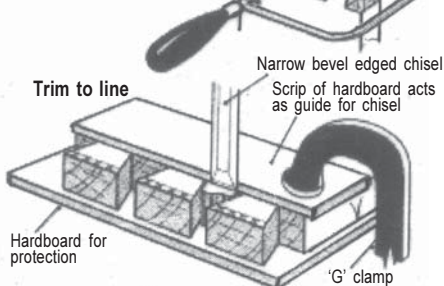

Assemble

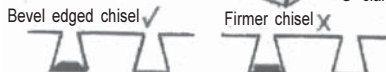
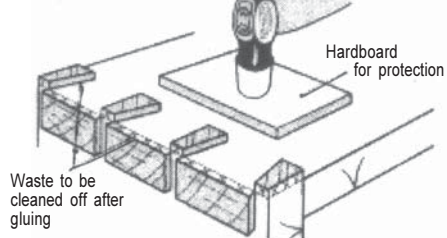

8.0 Tips for Correct Wood working:

- a) Select timber and cut to nominal size
(i.e. plan size plus an allowance for waste on ends.)
- b) Dress one side and one edge as required.
- c) Mark Face Side and Face Edge as shown.
- d) Reduce to required width and thickness as required.
- e) Cramp together all horizontal members together in vice or clamps.
- f) Mark out shoulder positions with a sharp H2 pencil.
- g) Repeat with Vertical members.
- h) Gauge mortise or halving lines.
- i) Mark out with a sharp HB pencil all other details including any haunches and the finished cross section on one end.
- j) Marking and gauging should be completed on all members before proceeding.
- k) Chop out all mortises taking care to exclude the haunch for the time being.
- l) Rip down the grain of the tenons but do not cut off shoulders at this stage.
- m) Prepare square mouldings i.e. grooves and rebates.
- n) Prepare round mouldings i.e. remainder including any chamfers.
- o) Cut shoulder lines carefully remembering to allow for rebates and any scribing required.
- p) Prepare any mitres or scribes.
- q) Fit joints, firstly individually and then as a frame correcting as necessary.
- r) Clean up inside edges and any inaccessible faces.
- s) Prepare and rehearse cramping making sure you have waste padding.
- t) Glue - up and cramp - up. Drive in wedges from outside corners first.
- u) Clean up back of work with smoothing plane.
- v) Clean up front of work.
- w) Cut off waste and clean up edges.

Chapter 5

DOORS AND WINDOWS

1.0 General:

Doors provide entry and exit to the building, whereas the windows provide entry of light and air into the building and ventilators allow escape of used up hot air out of the room or building. The location and size of the various openings is so provided, that the function of each is fully served. Beside the doors, windows and ventilators become a part of the furniture of the building and add to the aesthetics and decor of the building. These openings have to be strong enough to deter any intrusion by outsiders. It should be kept in mind that space leading to the door and room space in front of the door has to be kept vacant and eats into usable space of the building, it is therefore prudent to provide the number of doors which are necessary, many doors in a room should be avoided as far as possible.

2.0 Doors:

The location of door is at the floor level of the room/building. The height and width of the door has to be such that a normal person passes through it, without any inconvenience. Considering the height of a man to be under 1800 mm and girth under 1100 mm, height of a door 1850 mm and width 500mm would be adequate. However depending on the use of the room/building for some specific purpose, which may require passage of more than one person at a time or person entering the door with luggage on one's head, the width and height are varied. Passage of 2 persons at the same time would require a width of 1100 mm. Similarly, a person with head load may require a clearance of 2100 mm. However, in doors of wider openings, more than one leaf doors are provided. The main entry to the building would normally require passage of furniture etc. into or out of the building and require consideration. Waiting halls, main entry of railway station buildings, access to the F.O.Bs (Foot Over Bridges) are some locations where doors need more vertical opening.

The normal size of door openings adopted are as under:

| S.No. | Usage Type | Width | Height | Remark |
|-------|---------------------------------------|-------|--------|------------------|
| (1) | (2) | (3) | (4) | (5) |
| 1 a. | Residential : Main entry into a block | 1200 | 2100 | Double leaf |
| 1 b. | : Exterior doors | 900 | 2000 | — |
| 1 c. | - do- | 1100 | 2000 | Double leaf door |
| 1 d. | : Internal doors | 900 | 2000 | — |

| (1) | (2) | (3) | (4) | (5) |
|------|-----------------------------|------|------|--|
| 1 e. | -do- | 800 | 2000 | |
| 1 f. | : Bath and Toilet | 700 | 1900 | A loft can be provided above |
| 2 a. | Service : Main Entry Door | 1500 | 2100 | Non-modular, can be as per requirement |
| 2 b. | Door : Used for Public Room | 1100 | 2000 | Double leaf |
| 2 c. | : Toilets and Baths | 700 | 1900 | |
| 2 d. | : Other rooms | 900 | 2000 | |

Note: The above sizes are for modular construction of doors and are sizes of shutters as per I.S. Code. The gross opening in masonry has to be worked out adding the thickness of door frames and subtracting the depth of rebates.

2.1 Door Frames

The door frames are made from hard wood like Teak or any other similar wood. Section of the member for door frames should be minimum 100x65 mm for internal door and for exterior doors it should be minimum 125x65 mm. Many times Wire mesh doors are also to be fixed to the doors, specially the exterior doors, then the member for the door should be 25 mm extra i.e. 125x65 or 150x65. The vertical members of the frame are called 'Jamb' and the horizontal member at the top is called 'Head'. The Jamb should be long enough to be buried in the flooring thickness, below the final floor level, by minimum 40mm and the Head is extended by 75 mm on either side of the jamps, called 'Horns'.

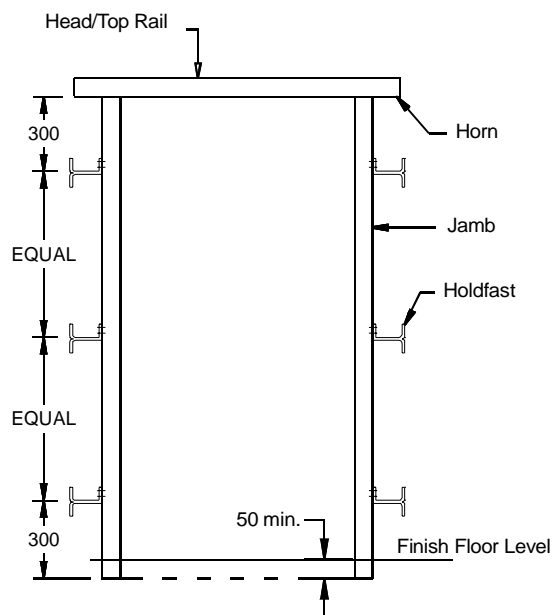

Door Frame

2.1.1 Making a door Frame:

- (i) The wood piece should be free from knots, blemishes, warps or bends. All the members i.e. jambs and heads should be of same species of timber and similar grain and texture. The wood should be seasoned and dry.
- (ii) The door frame has two no.'T' joints connecting the 'Head' and the 'Jambs'. These are jointed with through Mortise and Tenon joints. First determine the size of the members required and cutting length of members including the length of horns and the part to be buried in the floor.
- (iii) The detailed procedure for making a frame is given in para 6.0 of Chapter 4. The rebates and any chamfers if required, are to be made prior to starting the M&T joint. The rebate shall be 15 mm deep and width, equal to the thickness of door shutter. If wire mesh door also is required, frame shall have rebates on both sides of the members. The main door should open inside the room and the wire mesh door outside. The joints should be perfect and not require any wedges or fillers to tighten the M&T, the glue should be adequate to make the joint tight.
- (iv) The Mortise and Tenon are to be put together duly pasted with adhesive (Poly vinyl Acetate (Heavy Duty) - Fevicol or similar commercial product).
- (v) Check the diagonals, the angle at the joints and the horizontal spacing between jambs at the top, at middle and at the bottom. The frame should be true and square. If not make necessary adjustment.
- (vi) The frame is temporarily supported at the bottom, at the middle height and at the two angles at top by means of wooden struts and braces, to keep them in shape and prevent any distortion during storage or while fixing in place.
- (vii) The face of the wood members coming in contact with masonry or plaster and the portion buried in floor as well as the horns are given 2 coats of approved Anti-termite solution. One coat of primer is given to the whole frame, before storage.
- (viii) The frames should be stored in lying down position with the struts and braces facing upward. Next frame can be stacked above it but the head of one should lie on the bottom of another, to avoid any disturbance to the struts and braces.

2.1.2 Fixing the Frame:

The door frames can be fixed in the masonry either (i) while raising the masonry or (ii) after completion of masonry work in wall.

The method of fixing is primarily same in both cases, except that

while raising the masonry, no gap is required to be kept between frame and brick work for variation of dimension etc. and the hold fast is cast in 1:3:6 concrete along with raising of masonry. In the case where frame is fixed after wall has been erected, a gap of about 15 mm is left on all sides viz. both sides and top while raising masonry and the brick work at the location of hold fasts is left for 2 courses of bricks and filled with brick bats. The loose bricks are taken out and hold fasts are embedded in concrete 1:3:6. The gap between the sides and top of frame are filled up with mortar plaster after fixing the frame.

Procedure for fixing the frame

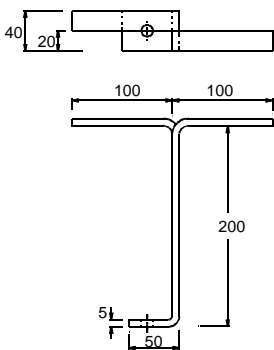
- (i) Three no. hold fasts are to be fixed on each of the outer face of the jambs, two nos. at 300mm from the top and bottom and third at the middle. The hold fasts are made from a 40x5 mm M.S. flat, 350 mm long. On one end the flat is split and forked at the center for a length of 100 mm and bent on opposite sides at 90 degrees. On the other end, the flat is bent at 50 mm upwards at 90 degrees. The 50 mm side is drilled with 2 holes of 6.5 mm diameter. The hold fasts are fixed using 2 screws of No.14 screws, and 50 mm long. Pilot holes of 3.6 mm diameter should be drilled prior to screwing.
- 
- (ii) Transfer the level at which the frame is to be fixed, from the main entry gate, by means of water level tube.
 - (iii) Temporarily fix the frame at proper level, checking the plumb from inner and outer faces. It is to be ensured that the door opening side is marked and the frame fixed accordingly. The frame has to be flush with the outside of wall and therefore, it is necessary that the frame is aligned, out wards by the thickness of plaster, which the masonry is to receive. This is 12 mm, normally.
 - (iv) The door frame is then fixed by casting the hold fasts in concrete of 1:3:6. the dimension of concrete is 300 x thickness of wall x 150.
 - (v) If there is a concrete column on one side, where the door frame is to be fixed, the horn on that side has to be cut and instead of the hold fast, a M.S. flat of 250x40x5 mm, 50 mm of which is bent at 90 degrees is fixed to frame and the concrete column by means of 50 mm long No. 6 screws, 2 nos. in wood and 2 nos. in concrete. In concrete holes have to be drilled of 4 mm diameter and Plumbers nails 6mm diameter and 50 mm long can be driven or screws of No.6 fixed. Care is to be taken that 12mm projection of door frame is kept on outside to accommodate the plaster thickness.

- (vi) Normally the door frame is provided with a wooden beading, after plastering work is completed at the joint of masonry with jambs to hide the gap created at this location.

2.2 Door Shutters: There are several types of door shutters known after the type of material used and their construction. Mainly these are,

- a) Flush doors
- b) Panel doors
- c) Glazed doors
- d) Wire Mesh door
- e) Batten doors (Ledge door)
- f) GI sheet door

2.2.1 Flush Doors: Flush doors are made in different materials.

- a) Ply Board Flush door
- b) Particle Board Flush door
- c) Batten frame flush door
- d) PVC flush door
- e) MDF board flush door

2.3 Flush doors:

The flush doors are very popular these days, specially for interior use because of simple construction, which can be done by an average skilled carpenter, less cost and good appearance. Flush door shutters have a solid or semi-solid core set in a framework of wooden stiles (verticals) and rails (horizontal), which is covered on both sides with either plywood or a face veneers giving a perfectly flush and joint less surface. Ready made flush doors are also available in the market of different sizes, however they can be made also from the basic material. This works out a little cheaper and many of the builders prefer to make flush doors rather than purchasing ready built doors. The flush door shutters normally available in market are as below:

| Width mm | Length mm | | | | |
|----------|-----------|------|------|------|------|
| | 1829 | 1930 | 1981 | 2057 | 2133 |
| 660 | A | A | A | A | N.A. |
| 685 | A | A | A | A | N.A. |
| 762 | A | A | A | A | N.A. |
| 787 | A | A | A | A | A |
| 914 | A | A | A | A | A |
| 965 | A | A | A | A | A |
| 1067 | A | A | A | A | A |
| 1118 | A | A | A | A | A |

Note A – Available, N.A. – Not Available

2.3.1 Flush doors can be made from, Ply Board, Block Board, Particle Board, MDF board, or soft wood battens covered with veneer on both sides. They could also be part hollow by the use of battens spaced with gap etc. A teak wood lipping is provided to all sides of flush doors. Flush doors undergo little expansion or contraction with seasonal changes because they use various boards manufactured under workshop conditions.

2.3.2 Flush doors are being moulded or manufactured in PVC also. The PVC doors are very light, water proof but are not as strong as wooden doors. Therefore they are generally preferred for use in bathrooms, office cabins, and such places.

2.3.3 Normal thickness of the flush door is 25, 30 or 35mm. Shutter of 25mm thickness is suitable for opening up to 1.5 sq.m. and above 1.5 sq.m., shutter should be 30mm or more thick.

2.3.4 Making a flush door:

(a) With Boards

- (i) Select the material from which the door is proposed to be made. The Ply Board and Block board are a stronger material compared to Particle board and MDF, specially as the latter soak water and can become *unserviceable* where they may come in contact with water. It is always prudent to pick up the size of plywood / Board of appropriate size as per opening of frame to minimize wastage.
- (ii) Cut the board to required size after deducting the thickness of beading/ lipping. The beading /lipping is normally 12 to 20 mm thick and of width equal to the thickness of door, which is fixed on all the edges of shutter. The lipping/beading is to be provided in a splayed or square cut with bigger dimension towards the rebate of the frame. Many times carpenters fix the lipping without splay or square cut, which can work out by constant banging of the door over a period of time.

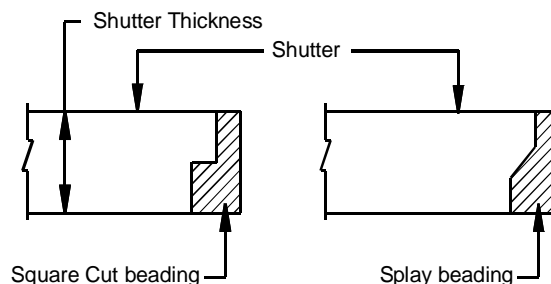

Beading / Lipping Patty

- (iii) Check the right angle of all the sides. Confirm that both the diagonals are same in measurement.
- (iv) Fix the veneer if required with adhesive and headless nails.
- (v) Fix Teak Wood beading/lipping *patti* on all sides of door shutter, after the veneer has been fixed and dried. Fixing of beading patti should be with using adhesive and nailed with headless panel pins 38 mm long, hammered at closer distance. There should not be any joint or splicing in the beading. The beading/lipping provides protection to the edges of the board, provides smooth surface and also reinforces the board to receive hinges.
- (vi) After fixing the beading patti, make marking of hinges on the shutter. Make recess for hinge. 4 No. hinges should always be provided in flush doors, because all the boards do not grip the screws with as much strength as hard woods. The depth and size of recess should be just matching the dimensions of hinge. It is necessary that at the upper location 150 mm below the top edge, two no. hinges are provided at a clear distance 100 mm apart. The lower hinge is provided after a clear distance of 150 mm from bottom and the central hinge at the center of the space between the 2nd and bottom hinge.
- (vi) Mark the location of lock rail.

(b) With wooden frame

- (i) Normally, hollow core flush doors are made using a wooden frame with two stiles and four rails v.i.z. top rail, intermediate rail, lock rail and bottom rail. The dimensions of the upper, intermediate and bottom rails and stiles is 65x25 mm. Normally the lock rail is kept 125x25 mm to receive the lock and aldop etc. The 'T' and 'L' joints are Mortise and Tenon. The 'T'

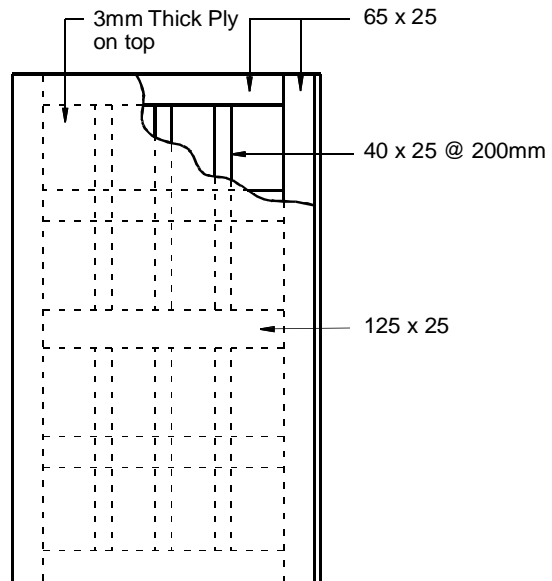

Flush Door

and 'L' joints should be provided with Secret stub tenon of 20mm. To strengthen the door, 3 to 4 Vertical battens of 40x25 mm are placed at interval of about 200 mm between the two stiles. Alternatively, 2 to 3 rails can be added over and above the 4 rails to divide the height in about 6 spaces with average gap of 300mm. The 'T' and 'X' joints are provided as lap joints for fixing the battens..

- (ii) 3-4 mm thick ply is cut to exact size and pasted on both sides of the frame with adhesive and nails.
- (iii) Lipping/ beading patti is fixed on all sides of the door using adhesive and panel pins.
- (iv) Recess for hinges are provided and pilot holes drilled.
- (v) The lock rail location is marked.

2.4 Panelled Doors:

This is the conventional and most usual variety of door and it consists of a framework in which panels are fitted. These are suitable for all the locations where Flush doors can be fixed. The main entry doors with 2 leaves are very commonly made as panel doors, besides several others.

The panel doors may be single leaf or double leaf. This type of doors minimizes the spoiling of looks and function due to tendency of shrinkage cracks in planks and presents a decent appearance. There can be several designs with 2,3,4,,5 or 6 panels.

The stiles (75x30 mm) are to be continuous from top to bottom and rails are joined to the stiles. The thickness of shutter is minimum 30mm. The bottom rail should be 200x30 mm, the top rail 125x30 mm and lock rail 150x30 mm. The panels can be wood planks or in Ply board. These days the ply board panels are preferred because of simplicity and less labour.

The thickness of panel is generally kept as 19 mm when in wood, but if ply board is used it can be 10-12 mm thick. The panels are secured in position by grooves housing made inside the edges of the framework. In single leaf doors, it is generally a practice to avoid munitins (Vertical member

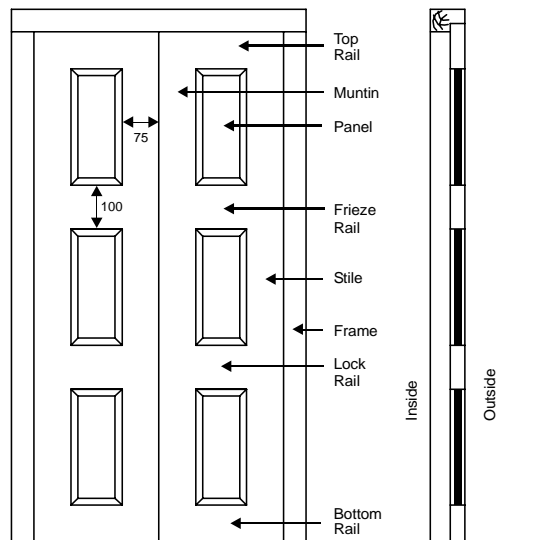

Paneled Door

dividing the width of panels) and provide panels covering the full width of shutter. This simplifies the construction and reduces cost.

The minimum recommended dimensions as per I.S. code, for the various elements of Panel or Glazed shutters are as under,

| S.No. | Element | Width (mm) | Thickness (mm) |
|-------|-----------------------------|-------------|----------------|
| 1. | Stiles, Top and Freize rail | 100 \pm 3 | 35 \pm 1 |
| 2. | Lock rail | 150 \pm 3 | 35 \pm 1 |
| 3. | Bottom rail | 200 \pm 3 | 35 \pm 1 |
| 4. | Muntins | 100 \pm 3 | 35 \pm 1 |
| 5. | Glazing bar | 40 \pm 1 | 35 \pm 1 |

2.5 Glazed Doors:

Glazed doors are provided to allow entry of natural light into the room as well as providing a view of outside. The glazed shutters are designed as fully glazed or may be partly glazed as per the requirement. Normally, bottom half, 1/3rd or 2/3rd height is paneled and balance is glazed. The shutters could be single leaf or double leaf. The glass panes could be in form of tiles or one piece.

The glass is fixed into the rebate of wooden glazing bars, stiles and rails. The glass panes are first fixed with headless nails and a wooden bead is fixed in the rebate. The bead is 6x 10mm or equal to the depth of rebate after subtracting the thickness of glass pane. Sometimes the beads are rounded and project out of plane of the door surface. The glass panes can also be fixed without bead and then putty is applied to the rebate forming a bevel edge with the glass. This arrangement may not look very pleasing but makes the joints almost air tight.

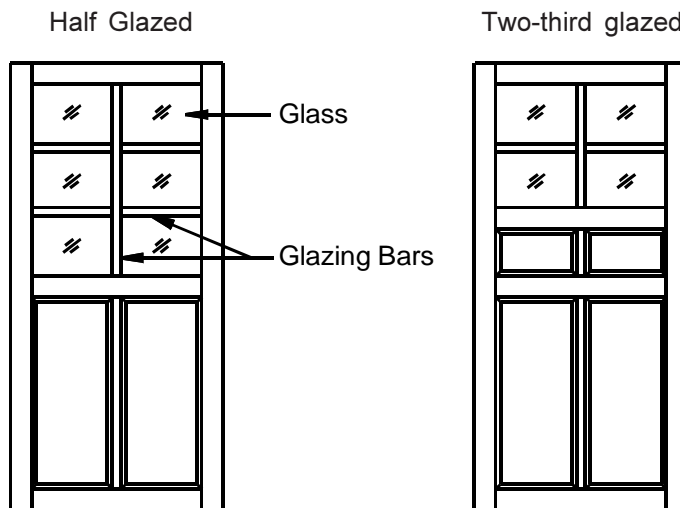

Glazed doors

2.6 Wire gauge shutters:

Fly proof wire gauge (wire cloth, wire mesh), is regularly woven with equally spaced galvanized mild steel wires or stainless steel wires in both warp and weft directions. Average width of aperture and the nominal diameter of the wire available commercially are as given in table,

| Specification of Black Wire Cloth, Plain Weave | | |
|--|--------------|----------------|
| Mesh/inch | Wire Dia. mm | Aperture in mm |
| 10 mesh x 10 mesh | 0.60mm | 1.94mm |
| 16 mesh x 16 mesh | 0.45mm | 1.138mm |
| Width: (1m, 3' and 4') | | |

| Specification of Stainless Steel Wire Mesh | | |
|--|-----------------|----------------|
| Mesh/Inch | Wire Gauge(SWG) | Aperture in mm |
| 20mesh x 20mesh | 30 | 0.95 |
| 30mesh x 30mesh | 34 | 0.61 |
| Roll width: 1m, 3' and 4' | | |

Each wire gauge panel shall be a single piece. Panel should be so designed that no single panel exceeds 0.5 sq.m. in area. In order to prevent sagging of wire gauge, 20 x 20mm square or suitable equivalent beading shall be provided on the external face in desired pattern. If panel of the shutter having any opening then beading should be provided from both the side of the wire mesh. The stiles of frame of wire mesh door shutter should have width of 100mm and bottom and top rail must be of minimum 150 mm wide. The thickness of shutter should be minimum 25 mm.

The stiles and rails are given a rebate to receive the wire mesh, which forms the wire mesh panel. Wire mesh shall be bent at right angles in the rebate of the stiles and rails, turned back and fixed tight with tacks at about 75mm centers, fixed alternately in the two faces of the rebates. Ensure that the wires of the mesh are perfectly vertical and horizontal in the line of shutter. The wooden beading or molding is fixed over it with brads or small screws at about 75mm centers. The space between the beading and rebates, where wire mesh is bent, shall be neatly finished with putty, so that end of wire mesh may not be visible.

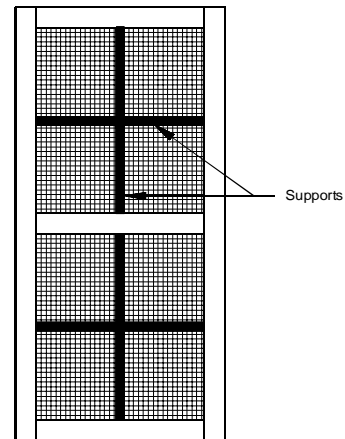

Wire gauge Shutter

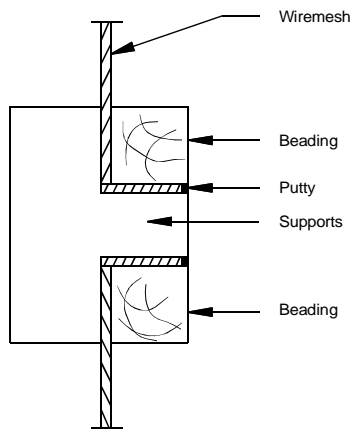

Fixing wire mesh

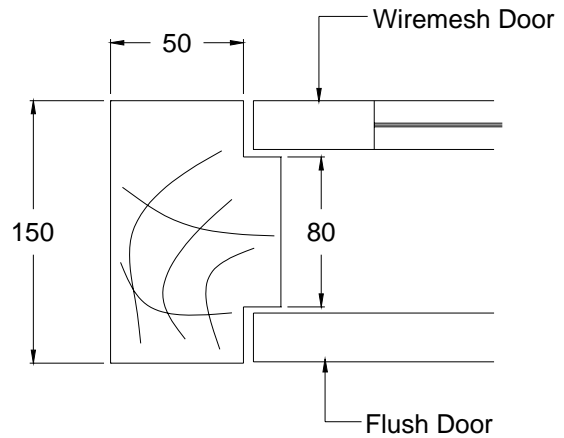

Frame for Wire mesh shutter (External)

2.7 Battened / ledge Doors:

This is the simplest form of shutter and it is used where appearance is not important. This is mostly used in storage areas, godowns, in the backyard entrance door.

This type of door is formed by vertical members of wooden planks called battens. The horizontal members which secure or hold the battens are known as ledges.

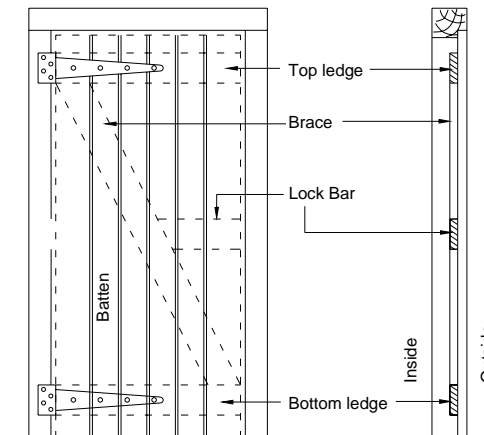

Battened / ledge Door – Single Brace

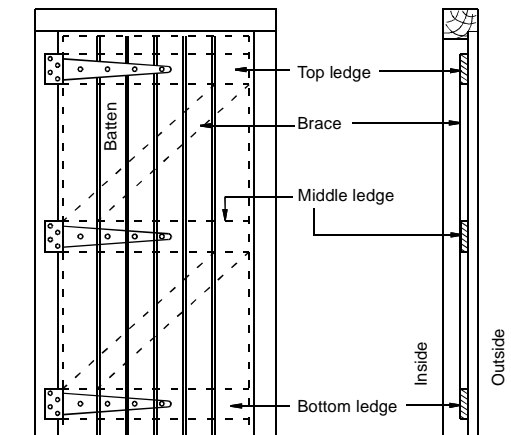

Battened /ledge Door – Double Brace

The battens are normally 75 mm to 150mm wide and 20mm to 30mm thick but of uniform dimensions. The ledges are generally 150mm wide and 30mm thick. Three ledges are generally provided at top, middle and bottom. The shutter is hung on 'T' hinges which are fixed on ledges.

It is usual to provide diagonal braces between the ledges to strengthen the door shutter for heavy duty use. The appearance of such a door is of double 'Z'. The battens are fixed with each other in a tongue and Groove joint, as shown in fig. The braces are 100-125 mm. The ledges and braces are fixed with wood screws from inside so that the head is not seen from outside. It is important that the braces start from near the hinge and incline upward /downward towards the middle ledge for better strengthening the door. In case all the ledges are provided with 'T' hinge, both braces can rise upward, for better looks. For rough work the battens are only lapped and braced without wood joints as mentioned earlier.

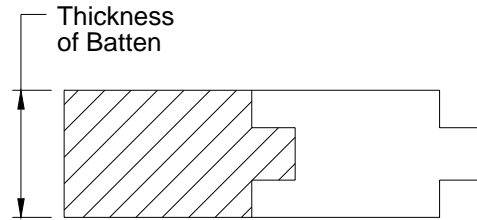

Tongue and Groove Joint for Jointing of Battens

2.8 G.I. Sheet Doors:

This type of shutter is used for compound gates. It is low cost door shutter and used where appearance and strength is not important. A wooden frame is made with suitable section, normally 65x30 mm. The 'L' joints could be Miter joints and the middle rail with 'T' stub Mortise and Tenon joint. Then G.I. Sheet, 18 Gauge is fixed on the frame from outside. A wooden beading of 25x12 mm is fixed from the outside with screws, to hide the nails and strengthen the connection. The M.S. black hinges are provided, minimum 3 in no. with the frame and middle rail is used for locking arrangement. The whole door is painted by oil paint after fixing.

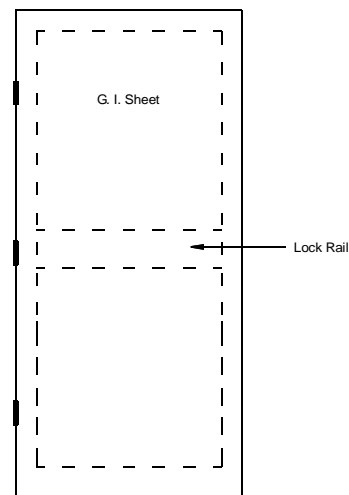

G. I. Sheet Door

3.0 Procedure for Fixing door shutters:

Step 1:

The shutters are to be fixed after finishing of floor tile work, plaster work, curing etc. so that there are no chances of damage of door shutter and the final floor level is fixed so one can give good clearance between the shutter and the floor.

Step 2:

First make marking of hinges on the shutter. Make recess for hinges. Normally this is done along with manufacture of door shutter. For side

hung shutters of height 1.2m, each shutter is hung on two butt hinges of size not less than 75mm at quarter points with woodscrews No. 8, having length of 30mm. For shutters of height more than 1.2m, each door shutters shall be fixed to the door frame with three butt hinges of size 100mm, one at the center and other two 200mm from the top and the bottom of the shutter. In case of flush doors or other door shutters made of soft wood, 4 hinges should only be provided. It is a good practice to provide 2 hinges close to each other at the top level i.e. at a clear distance of 100 mm from the top hinge which is 150 mm below the top of the door. The side hung doors exert maximum load on the top hinge and since holding power of screws in the boards and soft wood are less than for hard woods, the doors tend to sag down ward. Woodscrews of designation number 9, length 40mm, shall be used for fixing the hinges, which should be screwed with screwdriver and not hammered in.

Step 3:

Drill pilot holes as per the table given at para 3.6 of Chapter 3. The pilot holes should be drilled after accurately marking the position of hole. The center of the pin of the top hinge should be 5mm beyond the face of the door and that of the bottom hinge should be 6mm beyond the face of the door. The door is fixed a little slanting and any slight sagging which takes place initially is compensated.

Step 4:

Fix hinges to the shutter with one screw. Special care should be taken that the screw should be fixed with screw-driver and not to be hammered.

Flap of hinges should be neatly countersunk into the recess cut to the exact dimensions of the flap, in order that the door shall swing freely.

Step 5:

After fixing hinges to the door shutter, the door is to be put with the frame. By trying the door in the frame assess the clearance between floor and bottom of door. A beading *patti* of the thickness of clearance is temporarily kept on the floor for uniform clearance between floor and bottom of the shutter, and the door should be kept on the beading *patti* and the shutter held in position. Fix all the hinges to the frame with screw.

A clearance of minimum 5mm is kept between the bottom of the door and the finished floor level. The clearance can be kept upto 12mm as per flooring finishing and size of door. Some times, the flooring may not be at uniform level near the door frame, the same should be noted and accounted while deciding the thickness of beading *patti*.

Step 6:

After fixing the shutter to the frame, the work of polishing or painting as decided is done. If the door is to be painted, primer coat should be applied on it. After drying of primer wood putty should be applied, then after drying putty again one coat of primer is to be applied. Then one coat of oil paint should be applied. After drying first coat, second coat of oil paint should be applied. Fittings should be fixed after completion of painting work. The all fittings should be fixed at specified locations as mentioned later in this chapter.

Step 7 :

After finishing, door should be checked for easy operation and check clearance at bottom. Check the operations of all fittings.

3.1 Necessary precautions to be taken while fixing door frames and shutters:

- Door frames should be in proper plumb & level.
- Quality of door shutters should be good. Warping of surface i.e. formation of wave pattern on the surface of shutter & broken edges of the shutter should not be allowed to use.
- Bent shutters, or defects at edges and at corner places should be rejected.
- All hinges & other door fittings should be fixed only by screws. Hammering of nails should be prohibited.
- Primer, Putty & first coat of paint/ varnish should be completed before fixing any fittings on shutters.
- Once the shutter is fixed there should be nominal gap between shutter and frame which is required for working tolerance. There is 5 mm gap maintained on all four sides.
- Beading should be fitted to sides before fixing the shutter. This hides the gap between wall and the frame.
- No joints should be provided to cover moulding except for the corners where Miter joints are provided.
- All visible dents, scratches, unevenness etc. should be properly repaired by applying putty made from wood dust & resin. It should be properly scraped by using proper sand paper.
- As soon the door shutter is fitted, fix at least one aldorp per shutter for locking, so that shutter will not bang on door frame due to wind.

4.0 Windows:

The windows while should allow light and air into the room/building should not permit entry of dust, leaves and other litter from the street or the compound inside the building. Further the privacy of the occupants of the

building should not be violated i.e. the normal activities in the room/building should not be visible from the street or compound. The height of the window is therefore kept well above the floor level., a height of 1200 mm above the street or compound level is considered sufficient to meet the above requirements. Any thing above 1200 mm may obstruct the entry of air and light as well as view of outside and should not be adopted. Normally the sill level of the windows is kept between 900 mm to 1200mm. The height and width of the window could be provided as per the liking of the occupant and feasibility at site however, the size of modular window shutters as per I.S. code are as under,

| S.No. | Width | Height | remark |
|-------|---------|---------|----------------|
| 1. | 500 mm | 1100 mm | Single leaf |
| 2. | 460 mm | 1100 mm | Single leaf |
| 3. | 560 mm | 100 mm. | Single leaf |
| 4. | 500 mm | 1200 mm | Single leaf |
| 5. | 900 mm | 1200 mm | In double leaf |
| 6. | 1100 mm | 1200 mm | In double leaf |

Note: The above sizes are for modular shutters as per I.S.code and the gross opening has to be worked out after adding the thickness of window frame and subtracting the depth of rebates. In case of double leaf shutters, the width of each shutter shall be 460 mm and 560 mm, to obtain the shutter width as 900 mm and 1100 mm in S.No.5 and 6.

4.1 In India most of the places have Mosquito menace and therefore, it is prudent to provide Mosquito proof net on all window openings. On the ground floor and other windows, at upper floors opening on to the passages, provision of steel bars or grills is also necessary for safety considerations.

4.2 The windows have to be provided considering the layout of building for proper ingress of light and air, as per the good practices for layout of buildings.

The minimum window openings in a building should be about 20% of the floor area, of which at least 8% should be with glass panes.

4.3 Window Frames

The Window frames are made and fixed in the same manner as the door frames. In window frames the horns are provided both in the 'Head' as well as 'Sill'. Only two hold fasts are required to be fixed as the height of window frame is generally less than a door frame. The members for window frames shall be same as for door frames. In many cases, a M.S. grill or M.S. bars are fixed in window for security reasons. This however does not require additional width of wood member and it is fixed in between the Wire mesh shutters and glazed shutter. The glazed shutter is normally opened towards outside and the wire mesh shutter in side, however many people provide the

arrangement in the converse way. This arrangement is also followed where the wire mesh is fixed inside on the frame permanently. Where however only glazed shutter is provided and the wire mesh shutter is not provided, such shutters also open on the outside only. The rebate for the shutters is 15 mm deep and wide equal to the thickness of shutter. The advantage of opening the shutters outside is that the space in the room is not occupied by the opened shutters and normally wherever, the wire mesh shutters are provided will not be required to be opened except for closing or opening of the glazed shutters.

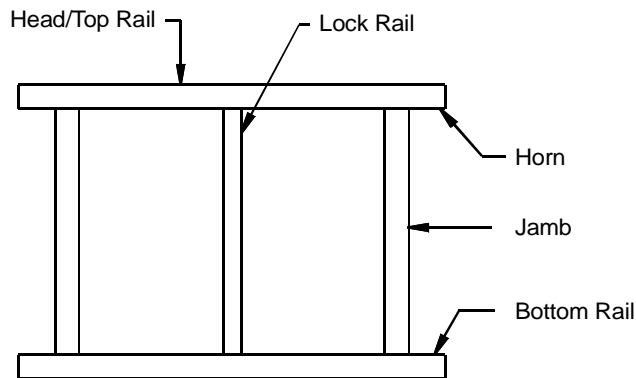

Window Frame

4.4 Window shutter:

Window shutters are mostly either fully glazed or partly glazed with bottom half or 2/3rd paneled. The shutters are made in the same way as paneled or glazed doors. The minimum dimensions of various elements of the window shutters as recommended by I.S. code are as under:

| S.No. | Type of Element | Width (mm) | Thickness (mm) |
|-------|------------------|------------|----------------|
| 1. | Stiles and rails | 80 ± 3 | 25 ± 1 |
| 2. | Muntin | 60 ± 3 | 25 ± 1 |
| 3. | Glazing bar | 40 ± 1 | 25 ± 1 |

The Stiles and rails are fixed with Mortise and Tenon joint. The Frieze rail is fixed using 'T' joint details and 'Top' and 'Bottom' rails are fixed with 'L' joint detail. The Glazing bar is also fixed using Mortise and tenon joints, using 'T' and 'X' details as given in para 7.3 of chapter 4. For glazing bar the practice is to provide the rebate for the glass panes on the outside of the door. The depth of rebate is 12 mm.

5.0 Ventilators:

Ventilators are essential normally, where either windows can not be provided, or if provided not opened due to extreme weather of winter,

summer or other external factors. It is also relevant to consider the height of the ceiling of the room/ building and if the ceiling is high, more than 3600 mm the ventilators in addition to windows will be useful. Many times the ventilators are provided as an extension of 500 mm, to the height of doors or windows. The ventilators should be provided above the lintel level of windows and the minimum dimensions should be 500x500 mm, if provided individually. The modular size of ventilator shutters as per I.S. code, is as under,

| S.No. | Width | Height |
|-------|---------|--------|
| 1. | 500 mm | 500 mm |
| 2. | 900 mm | 500 mm |
| 3. | 1100 mm | 500 mm |

5.1 The ventilators can be hung to the frame in 3 different ways,

- i) Top hung
- ii) bottom hung
- iii) Center hung

In all the 3 types the ventilators open outside. The top hung provide a shade against rain, however opening and closing offer some complication. The bottom opening suffer during rains and water can find way in if not protected by other means, however have convenient way of opening and closing by means of a chord hanging inside the room. Normally the rebates provided are sloping outside, for gravity to assist in opening, by means of a chord tied to the upper edge of the shutter. The center opening are the best and easy for operating as well as rain water also is prevented to enter by half opened height of shutter.

A mosquito proof net should be placed to safe guard against mosquitos. Many times one steel bar is also provided horizontally at mid height of the jambs to bar entry of intruders from roof level.

5.2 The minimum recommended dimensions of the various elements of a ventilator are as under,

| S.No. | Type of Element | Width (mm) | Thickness (mm) |
|-------|------------------|------------|----------------|
| 1. | Stiles and rails | 80 ± 3 | 20 ± 1 |
| 2. | Muntins | 60 ± 3 | 20 ± 1 |
| 3. | Glazing bar | 40 ± 1 | 20 ± 1 |

These days several types of fancy and toughened /safety glasses are in the market and can be used to have big panes, avoiding the glazing bars as far as possible. Bigger panels give better aesthetics as well as save labour in doing fine work like glazing bars.

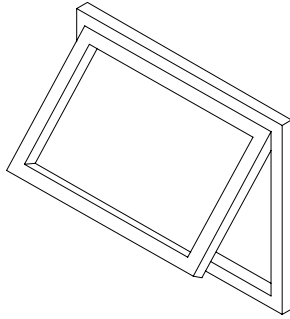
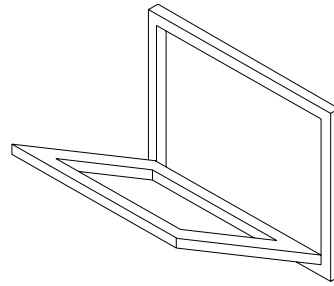
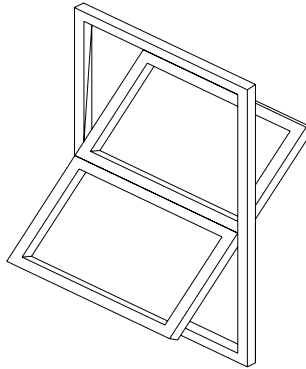
**Top Hung Ventilator****Bottom Hung Ventilator****Centre Hung Ventilator****6.0 Fixing the fittings :****Standard Recommended heights of fittings:**

Normal height of door fittings varies from site to site and as per individuals' convenience. But there should be certain universal standard to maintain the uniformity. Normally adopted heights and position of various door fixings and tabulated as given below.

6.1 Standard Recommended heights of fittings:

| Sr. No. | Fitting | Recommended heights from Finish Floor Level | Position of Fittings Single shutter | Position of fittings Double shutter |
|----------|------------------|---|---------------------------------------|---|
| (1) | (2) | (3) | (4) | (5) |
| | Main Door | | | |
| A | Inside | | | |
| 1 | Tower bolt | Top flush to top of shutter | 5cm (2") from opening edge of shutter | 5cm (2") from opening edge of locking shutter |
| 2 | Safety chain | 145 cm (58") | 5cm (2") from opening edge of shutter | Not Applicable |

| (1) | (2) | (3) | (4) | (5) |
|------------------|---------------------------|--------------------|--|--|
| 3 | Eye piece | 145 cm (58") | At centre of shutter | At centre of Locking shutter |
| 4 | Handle | 120 cm (48") | 6.5cm (2.5") from opening edge of shutter. | 6.5cm (2.5") from opening edge of both the shutters. |
| 5 | Night latch | 100cm (40") | Opening edge of shutter | Not Applicable |
| 6 | Sliding bolt (Tadi patti) | 85 cm (34") | At the opening edge | At the opening edge |
| 7 | Rubber stopper (gattu) | 7.5cm (3") | 7.5cm (3") from opening edge of shutter. | 7.5cm (3") from opening edge of shutter. |
| B Outside | | | | |
| 1 | Unit Number plate | - | On the head rail of frame. | On the head rail of frame. |
| 2 | Name plate | 167.5 cm (67") | Centre of shutter | Centre of locking shutter |
| 3 | Handle | 110 cm (44") | 7.5cm (3") from opening side edge of shutter | 7.5cm (3") from opening side edge of shutter |
| 4 | Aldrop | 90 cm (36") | 5cm (2") from opening side edge of shutter | 5cm (2") from opening side edge of shutter |
| 5 | Door stopper | As per requirement | 7.5 cm (3") from opening edge | 7.5 cm (3") from opening edge |

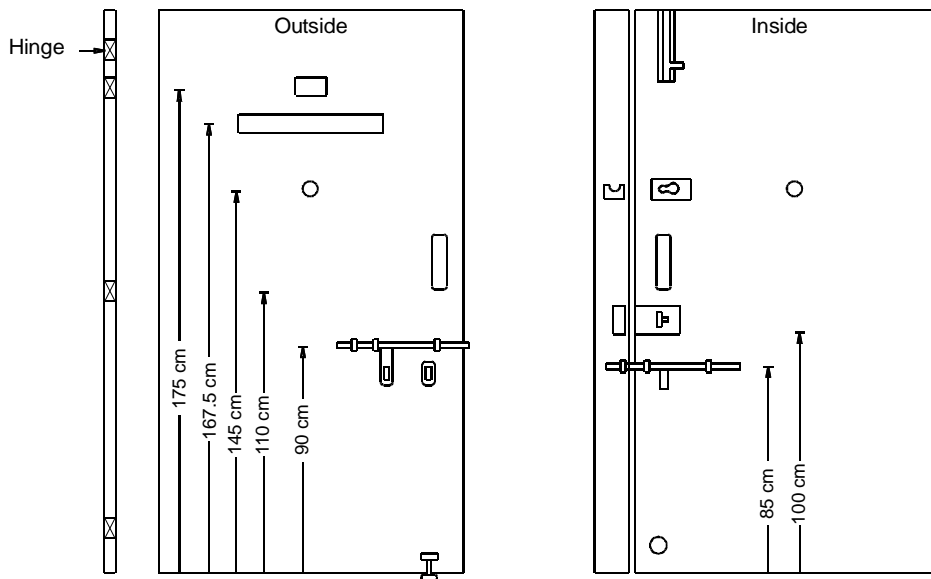

Standard locations for various fittings of door

6.2 Fixing the fittings on Doors/Windows/Ventilators

- (a) **Tower Bolt** : The description of different types of tower bolts is given in Chapter 2. The tower bolt along with its catch is positioned on the top of the door or window, such that the tower bolt is flush with the top of the shutter and the catch is holding the bolt for full height as also flush with the bottom of the “head” frame, after the shutter is fully closed. The position of holes in the catch are marked on the frame with pencil. 2.8 mm diameter Pilot holes are drilled and the catch is fixed with No.6 screws, 30 mm long. The bolt is then positioned in the catch and holes location is marked on the shutter by pencil. Pilot holes of 2.8 mm diameter are drilled at the marked locations and bolt is fixed in position by No. 6 wood screws, 25 mm long. Normally two no. tower bolts are fixed per shutter, one at the top and other at the bottom.
- (b) **Safety Chain**: Safety chain is fixed on the inside of main entry door, in case of a flush or single leaf panel door . It is helpful for opening the door slightly to converse with the visitor helping the resident to identify him. It is not a replacement of any of the safety fittings on the door, but an additional precaution. If a eye piece is fixed in the shutter, this may not be required. It is fixed by 2 no. of wood screws 6 no. 25 mm long, on the frame and another 2 no. screws on the shutter.
- (c) **Aldrop**: The aldrop is fixed on the outside at the entry gate, and it has facilities to put a pad lock. The diameter of the bolt in aldrop is 12-15 mm and it is caught in a hole of matching diameter in the jamb. In case it is fixed on double leaf door, a matching catch is to be fixed on one of the shutters. Normally it is fixed by wood screws, 9 No. 30 mm long, but these can be unscrewed from outside and is not very safe arrangement for fixing with wood screws. There are designs available in brass casting aldrops, where the main lugs as well as catch have machined threads and can be fastened from inside also, using metal bolts. With this arrangement, the aldrops will not come off even after unscrewing from outside and are much more safe.
- (d) **Door Handle**: the door handles are available in standard “C” or “D” shape as also in many fancy shapes. General length of the handles is 100mm to 150 mm. and these handles appear very neat as are fixed from inside with machine screws. There are several other types also available and are fixed with wood screws, normally 3 Nos. of 6 no.
- (e) **Rubber stopper**: The rubber stopper or *gattu* is fixed either on the wall or on the door shutter itself. It prevents the door to hit against the wall and maintain a specified distance from the wall. This is fixed with one wood screw, length depending upon the distance to be kept

between wall and shutter. They are available in varied lengths from 50mm to 125 mm.

- (f) **Mortise Night Lock:** A mortise lock is generally, of single spring bolt which can be withdrawn from outside by a key, and from inside by a handle/ knob. This has an arrangement whereby the lock can be prevented from being opened by its key from outside, while the night latch is used inside the room. These are available with two bolts also. This has to be set in the thickness of the door, in the mortise according to the dimensions of the latch. A slot is also created in the frame to catch the bolt.
-

Chapter 6

ALUMINIUM SLIDING WINDOWS

1.0 Introduction:

In recent modern houses aluminum sliding windows are widely used for windows. These windows are attractive, light in weight, easy to fix and need less maintenance, if properly fabricated and fixed.

Aluminium windows with big spans can be made with two, three or four tracks depending upon opening of window and number of shutters required.

Aluminium windows are available with powder coated surface. Powder coating can be done in different colours. Aluminium windows without powder coating are also extensively used.

2.0 Material:

The aluminium section are extruded by most of the manufacturers and available in three types namely light section, Medium sections and heavy sections. Based on the location, span and area of opening the appropriate section can be selected.

- a) The light sections are normally used for internal windows having opening span of less than 600mm.
- b) The medium sections are used for external windows and spans exceeding 600mm with the opening area upto 2.1 sq.m.
- c) Heavy sections are normally used for opening above 2.1 sq.m.

2.1 Frame section:

The frame of aluminium window works as a base for track section. It is fitted on the sill, wall opening and soffit or lintel i.e. all around the sliding window. The frame consists of rectangular Aluminium section. They are manufactured in three different unit weight as light, medium and heavy.



These are to be used depending on criteria given above in para 2.0. The dimensions and unit weight of sections are given in Annexure 1.

2.2 Track:

The shutters move on the track section. It is fitted to the frame. The track sections are available in various types like 2-track, 3-track, 4-track etc. There are two types of track sections required for each window, one is

bottom track section and another is top & side track section. The bottom track section has additional part i.e. runner, on which the roller / bearing runs.

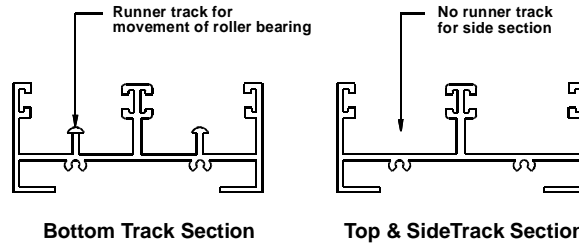

Two Track Section

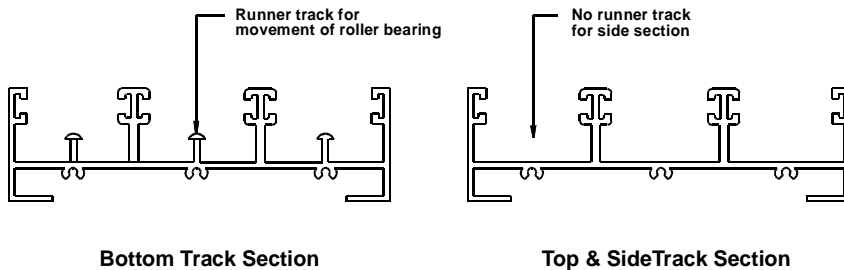

Three Track Section

2.3 Shutter Section:

The shutter actually moves on the track. It has rollers at the bottom and shutter section hold the glass with gasket.

Each shutter requires three types of sections.

- a. **Shutter Top & bottom section:** This section fits to shutter in top and bottom. The shutter having same section at top and bottom. At section 'a' and 'l' below.
- b. **Shutter interlock section:** This section fits to shutter on side i.e. in vertical position where another shutter is going to be interlock. All the middle shutters have interlock section on both the sides. The side shutter has interlock section on opposite side of wall. At section (i-i) and (n-n) in the figure below.

Shutter handle section:

This fits to first and last shutter on the wall side of first and last shutters. At section (j-j) and (d-d) in the figure below.

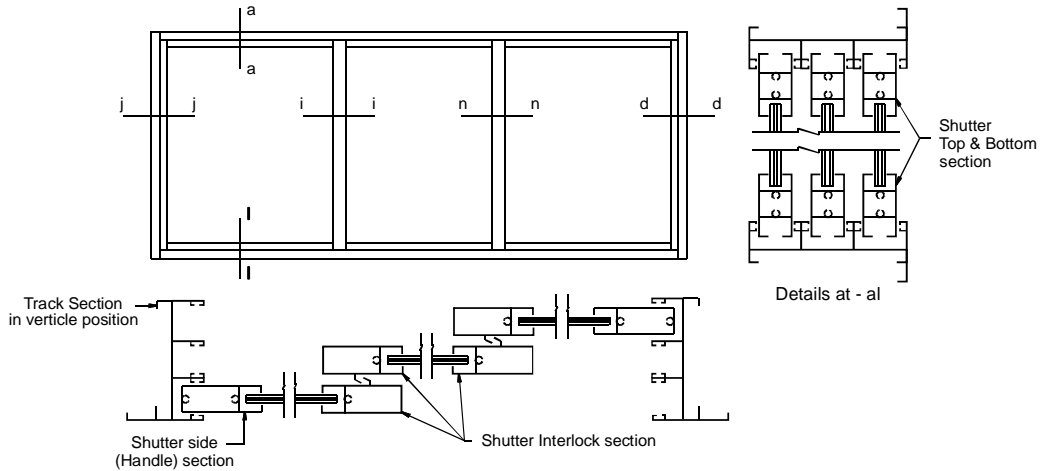

2.4 Roller:

Roller is made in P.V.C. and is fitted to door shutter section at the bottom. Roller moves on track section and makes smooth movement of shutter. Each shutter must have minimum two rollers. In the local terminology roller is also called as bearing.

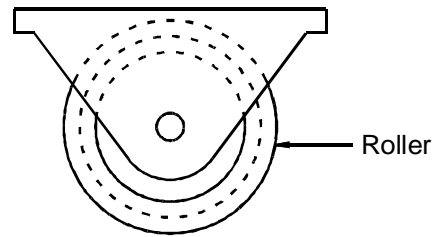

2.5 Gasket:

The Gasket holds the glass in the shutter section. The Gasket is made of PVC or Rubber. The PVC gaskets are more durable.

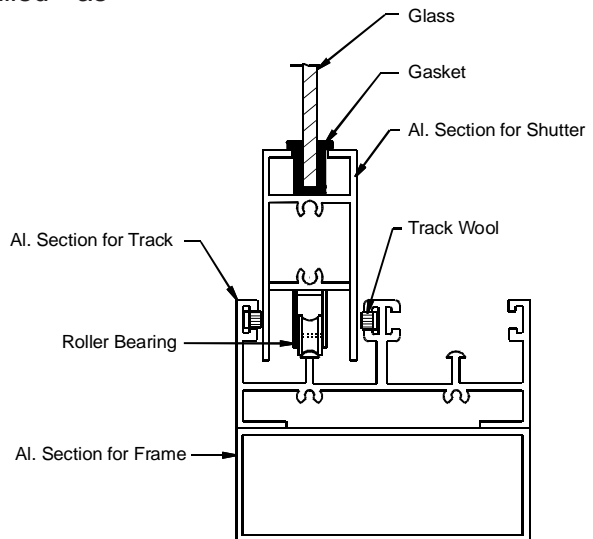

A sliding window consists of all main elements Namely a) Frame b) Track and c) Shutters d) Roller e) Gasket f) Track wool3.0

3.0 General arrangement:

The arrangement of Aluminium Sections and other accessories used in two track Sliding Windows are shown here:

3.1 Procedure for making Frame :

Aluminium windows are generally fixed after the internal and external plastering is over when hold fasts are not being used to fix the frame to the masonry. However, when hold fasts are to be fixed, a recess in the masonry is to be created to receive the hold fast, then cast in P.C.C. and plaster has to be given over the recesses later on.

1. Measurements:

- First of all, measurements of the opening should be taken.
- For fixing the aluminium window, the opening must be exactly in right angles and the diagonals of the opening must be equal, otherwise there will be gap between windows and plastered surface of wall.
- Measurements of length and height must be taken at three or four locations for each window, to ensure the conformation for size of fabrication of window of proper size.
- The gaps are not allowed in view of future leakages. If gaps occur due to mistake in the plaster, that gap is to be filled with Silicon sealent.

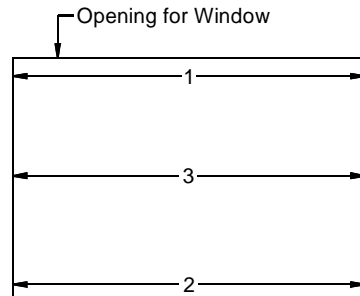

**Measurements
at three locations**

- a) Care should be taken to erect the window in such a manner that horizontal and vertical members should be exactly in right angles. Rectangular tube sections are used to make frame for sliding window. It is always advisable to provide frame to the sliding window. The frame provides stability to the window as well as proper fixing to the masonry.

The sizes of tube sections for window frame are shown in the table below according to number of tracks for window.

Frame sections and cleats used for various track.

| Sr.No. | Window type | Frame Section (Rectangular Tube Sec.) outer dimensions | Cleat (Angle) |
|--------|-------------|---|--------------------|
| 1 | Two track | 63 x 38.10 | 38.10 x 38.10 x 60 |
| 2 | Three track | 101.60 x 25.4 | 19 x 19 x 96 |
| 3 | Four track | 127 x 25.40 | 19 x 19 x 122 |

- b) The tube sections are to be cut in the proper size as shown in the figure. The vertical frame section should be in full height of opening, top & bottom sections of frame are short length and fit inside the side sections.

The cutting of aluminium section can be done by hack-saw but it is always better to cut by cutting machine to obtain a perfect right angle and smooth finish.

- c) The wooden batten of minimum 450mm long are to be put inside the vertical tube sections at the ends as shown in the figure. On these vertical sections cleats as well as hold fasts are to be fixed.
- d) The channel section can be used for making frame and wooden batten is to be put inside the channel for full length. It is more sturdy than the hollow tube sections.
- e) After cutting the track sections in size, put track wool in the frame sections in the groove, as shown in the figure under para 3.0.
- f) Fix the cleat angles to the vertical sections of frame at both the ends. The gap is to be kept, equal to web thickness of the frame section, from the end of vertical section. The cleat angle sizes are mentioned in the table. The angle cleats are available in various thicknesses from 1.5mm to 3mm and sizes. The cleats are fitted with two full threaded and plated metal screws of 3mm dia and minimum 15mm long. Each angle cleat must have minimum two screws on each surface i.e. four screws to each cleat. The screw should be entered in the wooden batten.

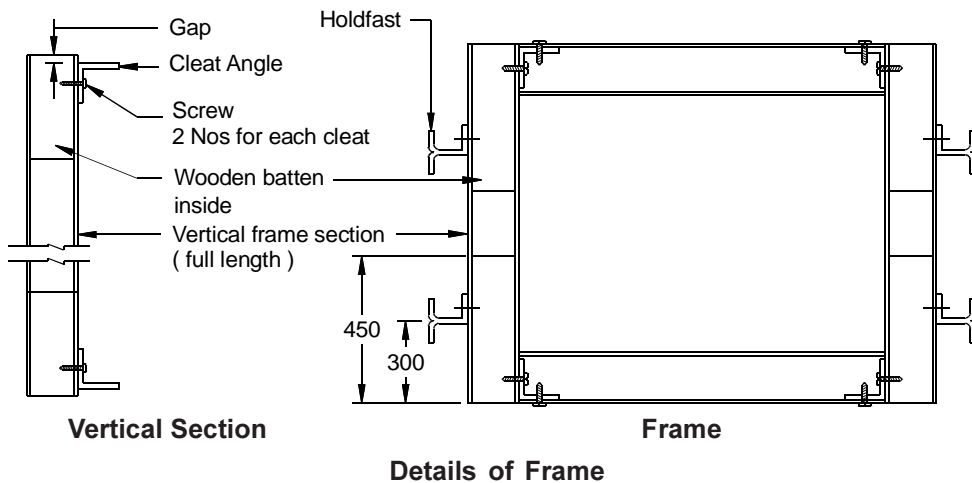

- 2) After fixing cleat to the vertical sections of frame, the top & bottom sections to be put on the cleats of vertical section, the cleats go inside the top & bottom section. Then fix the Top & bottom sections to the cleat with screws.
- 3) a) The holdfast is to be provided on both the vertical members of the frame. In the commercial system the holdfasts are not provided and

the frame is fixed to wall only with screws into wooden plugs in the masonry but it is always better to provide holdfast.

- b) In case of external windows, show-cases of commercial establishments, holdfasts must be provided.

Two hold fasts are fixed to the verticals on either side screwed into the wooden batten, fixed inside the hollow tube.

- 4) If hold fasts are not provided, fix the frame to the wall opening with screws of dia 8mm and 75mm long. The wooden plug / raival plugs is to be put in the drilled holes before screwing in the wall. The rectangular section frame is to be fixed to the all around the opening of window with screw. The first screw on all members from their end should be on 100mm and then spacing of screw should not be more than 45cm on each member of frame.

3.2 Fixing tracks to frame:

Bottom track is heavier than the other tracks because it has extra runner for roller bearing.

- 1) The tracks to be cut as per the inside dimension of frame. The corners be cut at 45° as shown in figure using a mitre box.
- 2) The angle cleats to be fixed to the bottom track as shown in figure. The top track will also have angle cleat.
- 3) The bottom track is to be fixed first i.e. before fixing side and top track to the frame. The screw size should be 6mm dia and 25mm long. Then fix the side tracks to bottom track cleats then fix to the frame. Lastly fix the top track.

3.3 Making Shutters:

- 1) To calculate the shutter size take the measurement of window opening. Deduct the frame section thickness twice (2A), then deduct the clearance of centre web (B) of track section twice from frame. For

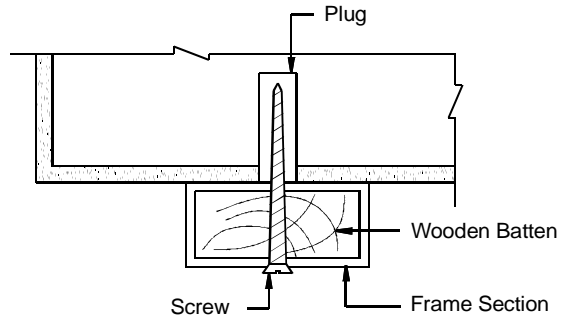

Fixing Frame with Screw

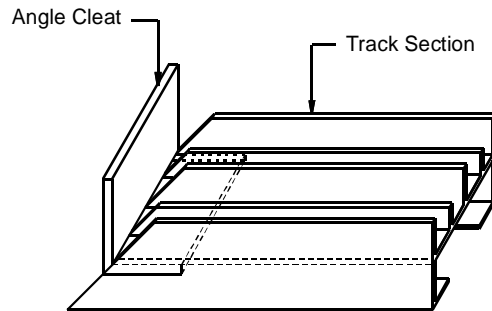

Fixing cleat angle to track section

vertical measurement the runner height of bottom track section is to be deducted additionally i.e. 'C' as shown in figure. This should be physically verified by measurements also.

$$\text{Shutter Size} = \text{opening} - 2 (A + B) - C - 3 \text{ mm}$$

2. Put the marking on shutter section according to the measurements of track sizes.
3. The side sections like interlock and handle section should be in full length. The top and bottom sections are fixed with a L-Butt Joint in between the side sections.
4. The bottom ends of side sections are to be cut in 'U' shape for creating space for accommodating runner track of bottom track section. This 'U' also facilitates fixing one of the two screws to bottom shutter section. Another hole is drilled just above 'U' for facilitating second screw matching the projected lugs with threads in the bottom section.

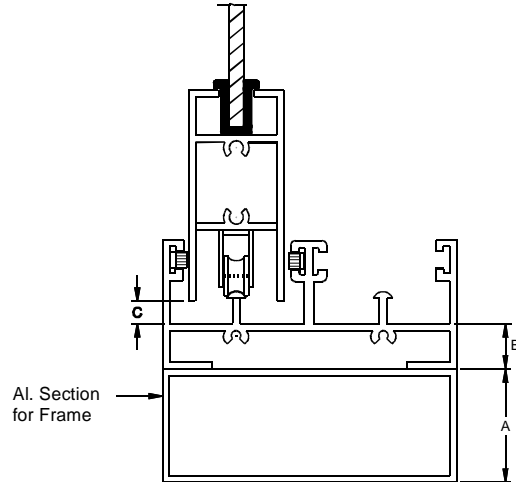

Shutter size Calculation

runner track of bottom track section. This 'U' also facilitates fixing one of the two screws to bottom shutter section. Another hole is drilled just above 'U' for facilitating second screw matching the projected lugs with threads in the bottom section. The top end is drilled with two holes for fixing the screw to top sections matching with the position of lugs in the top member.

5. First take bottom section and fit two roller bearings to it on either ends with 25 to 50mm margin from the ends.

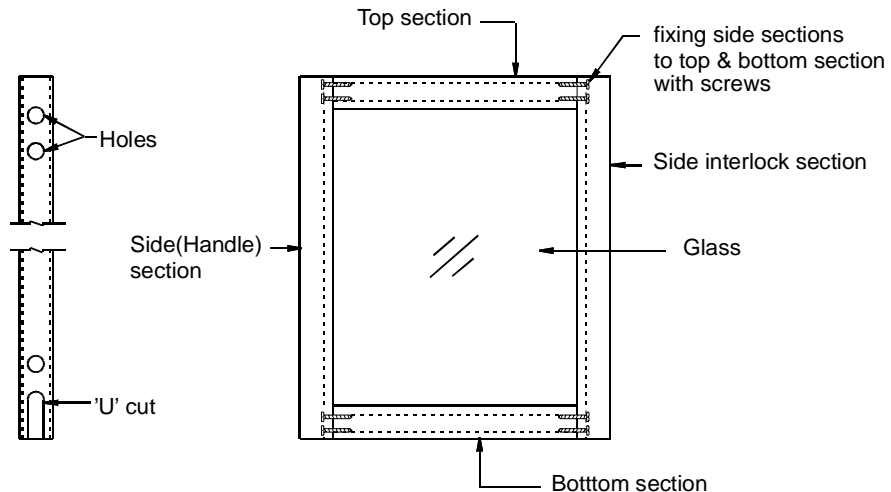

Shutter Frame

6. Put the gasket inside the shutter bottom section and then put glass into the gasket.
7. Put the gasket to all sides of the glass.
8. Put the side sections to the glass according to the position of the shutter. The end shutters have handle section to one side and interlock section to the other side. Put the top section on the glass.
Fix all the sections with metal screws of 3mm dia and 25mm long coated with anti-corrosion layer as shown in figure. The screws fit with self threading in the lugs (3/4th circle) part of the extruded section.

3.4 Fixing shutters in the track:

- 1) Remove the top track which is fitted in step 3. It is necessary to first fit and then removing of top track for perfect arrangement of tracks and shutters.
- 2) Put the shutters in the bottom track and hold it inclined. Put top track on the inclined shutters. Push the assembly in the frame from top side. Fit the top track section to the frame with screw.

3.4.1 If the height of the shutter is excessive the height of shutter is to be halved a glazing bar is to be provided in between, then the section used for the top or bottom section of shutter is used as glazing bar. The figure shows the arrangement of fixing glass and other accessories.

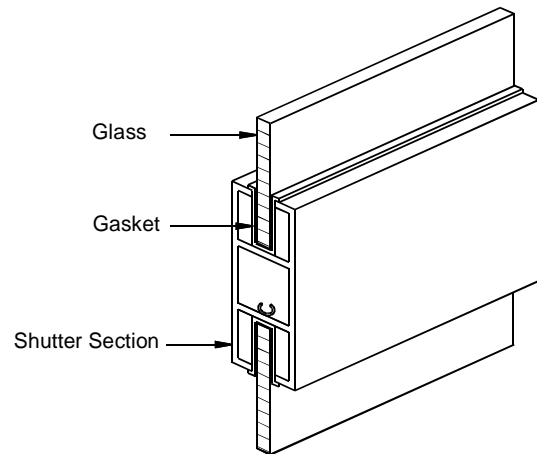

Glazing Bars to Aluminium Sliding Windows

3.5 Checking:

- The sliding operation of shutters should be checked for its free movement.
- Tracks should be cleaned with the help of vacuum cleaner or air blower.
- The gaps formed in between walls and windows should be grouted with epoxy based rubberized compound or silicon sealant such as toughseal or polysulphide with the help of grouting gun.
- If required M.S. grill should be fitted from outside for safety purpose.

3.6 To fit Jali shutter in sliding window, the wire mesh / Jali is put in to the shutter section. Pull the mesh from all sides. Then push a 'U' channel in to the groove of shutter section and fix it with screw.

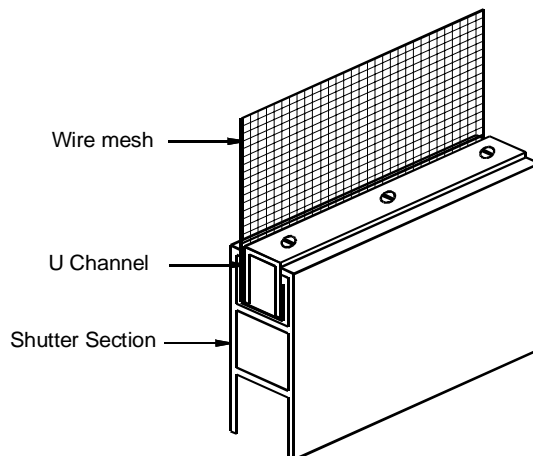

Fixing Wire-mesh to the shutter section

The various extruded sections as given in the catalog of M/s Jindal Aluminium are given as Appendix 1 to 3.

The Aluminum section of medium weight and thickness should be used for external windows with the shutter size upto width 25mm and the span up to 610mm. For the span above 610mm heavy section should be used and shutter size should be 30mm or more.

Appendix-1

Rectangular Tubes:



| Sr. No. | A | B | C | Weight Kg/m |
|---------|--------|-------|------|-------------|
| 1 | 63.00 | 38.10 | 1.47 | 0.781 |
| 2 | 63.00 | 38.10 | 2.10 | 1.093 |
| 3 | 63.00 | 38.10 | 2.95 | 1.516 |
| 4 | 101.60 | 25.40 | 1.10 | 0.739 |
| 5 | 101.60 | 25.40 | 1.35 | 0.906 |
| 6 | 101.60 | 25.40 | 1.63 | 1.089 |
| 7 | 127.00 | 25.40 | 1.30 | 1.052 |
| 8 | 127.00 | 25.40 | 1.79 | 1.439 |

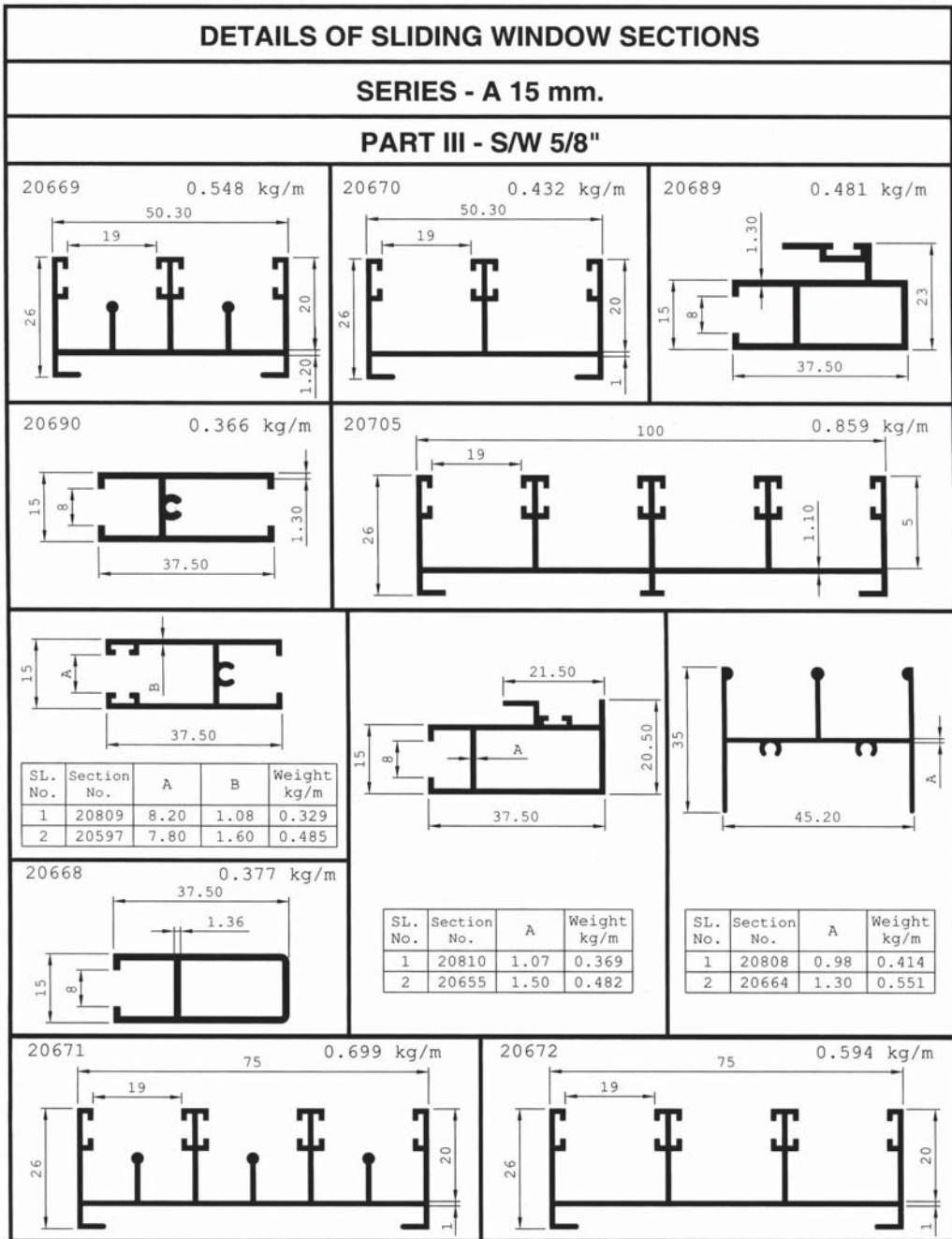

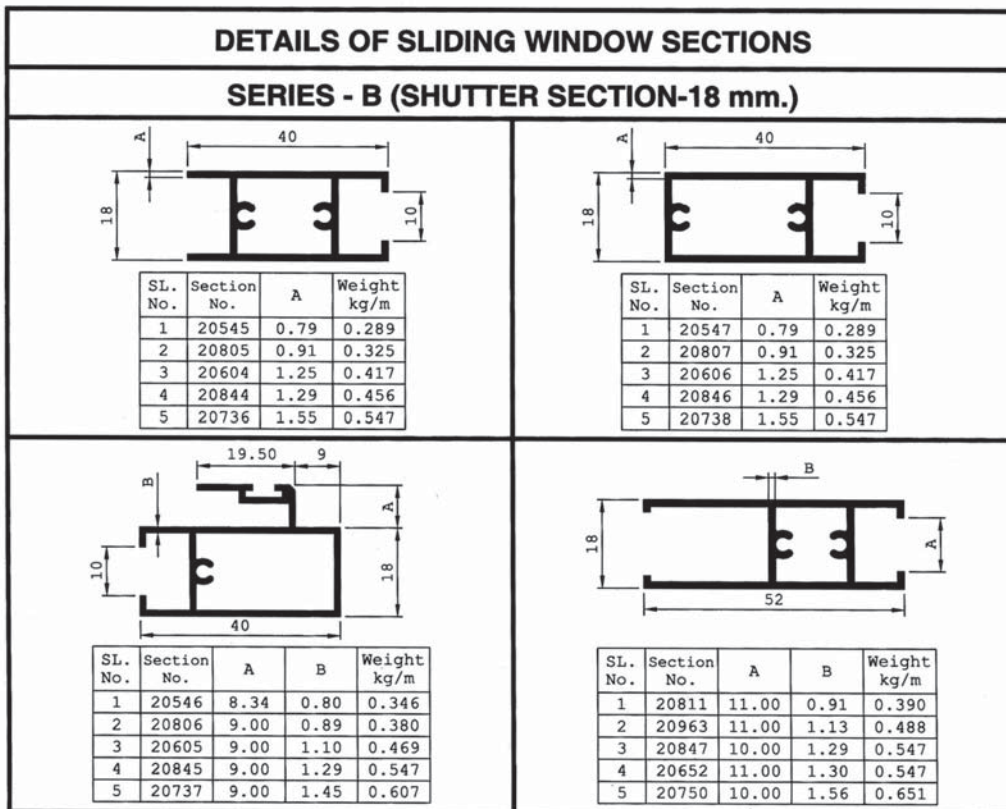
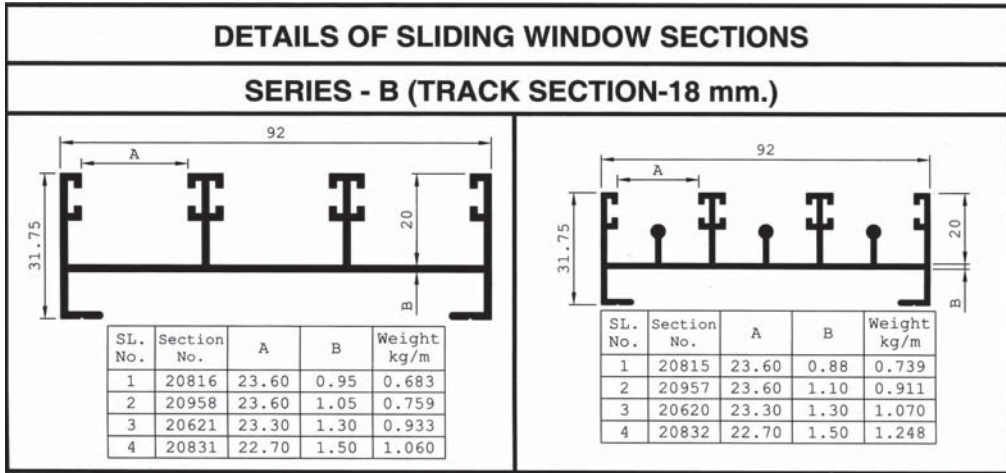

Chapter 7**GLAZING****1.0 Glass:**

Glasses are used in doors and windows because it transmit diffused light, to achieve privacy with dark glass and to get some decorative features to the building. Many types and varieties of glasses are available in the market. Out of these, ordinary glass, tinted glass, tempered glass and laminated glass are normally used in building construction.

1.1 Types of Glass:

- a. Sheet Glass or ordinary glass
- b. Tinted glass
- c. Tempered glass
- d. Laminated glass
- e. Wired glass

a. Sheet Glass or ordinary glass:

It is made by Soda, Silica and lime. The combination of this material is heated in the furnace to melt and fuse. Molten glass is pulled vertically through rollers. This glass goes through the annealing process and is also known as annealed glass.

b. Tinted glass:

While making sheet glass different colours are added to it. This reduces the sun light entering inside and also reduces solar heat in the building. It is used in the Airconditioned premises and wherever sun light has to be reduced. Apart from colour it has the same properties as that of parent glass.

c. Tempered glass:

Tempered glass is strong and has more resistance power to wind pressure. If it breaks, the resultant shards are granular in shape and prevents injury to people.

The glass is heated to its softening temperature and then suddenly cooled down.

It is used in commercial building, Shops as curtain walls and main doors etc. As this glass is more strong, it is used for frameless doors also.

d. Laminated glass:

While making this type of glass, two elastic lamination films are provided from both the sides to the glass. The glass is bounded in the two films. If this glass is broken the glass particles remain there in broken condition.

e. Wired glass:

In this glass steel wire mesh is used as reinforcement. This type of glass is stronger than the normal glass. The wire mesh prevents the broken glass pieces from falling out.

1.2 Guidelines for use of Glass in Structures:

The glass sheets when used as structural elements receive mainly load due to wind and also accidentally human impact. It is considered that if the glass is located between final floor level and 750 mm above it, it is the most vulnerable condition when maximum load can come due to human impact. Accordingly, certain conditions based on i) edge support ii) Location of glass sheet with reference to final floor level and iii) type of glass are recommended as under,

1.3 Four sides framed glass:

In case of framed glass panels supported on four sides and placed between the finished floor level and 750 mm, the maximum allowable area of the glass panel is as follows :

- a) The maximum area of the normal or annealed glass shall be less than equal to 0.5 sq.m. The maximum area of the safety glass depending upon its thickness shall be within the permissible maximum area as defined in the table (A) given below.

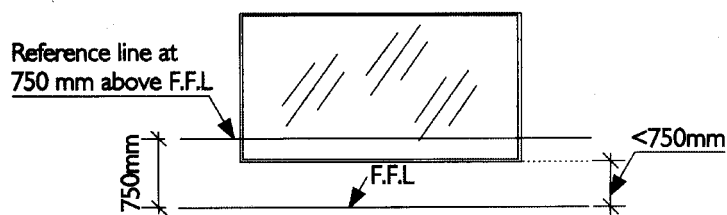

Glass supported on all four sides

Table A : Thickness and permissible area of glass

| Type of Glass | Nominal thickness (mm) | Maximum allowable area (sq.m.) |
|------------------------|------------------------|--------------------------------|
| Tempered Safety Glass | 4 | 2 |
| | 5 | 3 |
| | 6 | 4 |
| | 8 | 6 |
| | 10 | 8 |
| | 12 | 10 |
| Laminated Safety Glass | 6 | 2 |
| | 8 | 3 |
| | 10 | 5 |
| | 12 | 7 |

- b) In the case of ordinary annealed glass panels supported on all four sides starting above 750mm or a protection / transom / chair rail is in place permanently from the finished floor level, the thickness of annealed glass shall be within the permissible maximum area as defined in the table B.

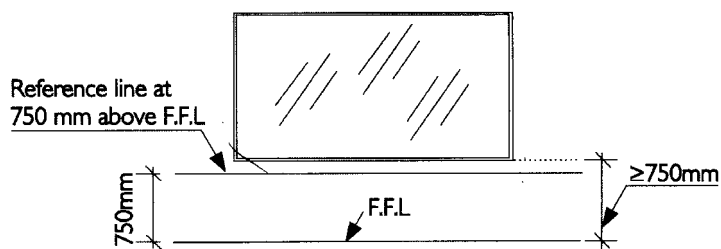
**Glass supported on all four sides****Table B : Annealed glass (Ordinary Glass)**

| Nominal Thickness (mm) | Maximum allowable area (sq.m.) |
|------------------------|--------------------------------|
| 4 | 0.8 |
| 5 | 1.2 |
| 6 | 2.1 |
| 8 | 3.2 |
| 10 | 4.4 |
| 12 | 6.3 |

1.4 Two / Three sides Framed Glass:

In case of glass panel supported on two/three sides above 750 mm or has a protection from the finished floor level, then annealed glass can be used in following cases as mentioned in the Table C, else tempered or

laminated glass shall be used.

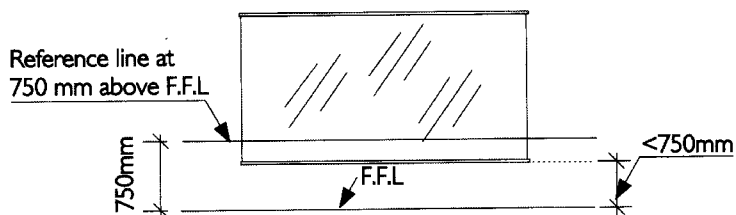

Glass supported on two sides

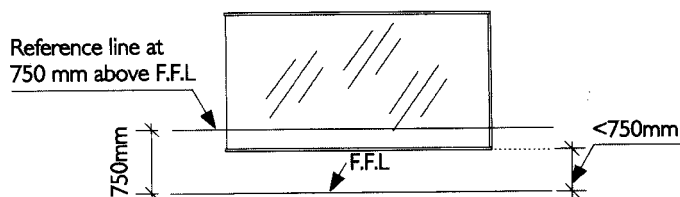

Glass supported on three sides

Table C:

| Nominal Thickness (mm) | Maximum allowable height of glass (m) | Maximum allowable glass area (sq.m.) |
|------------------------|---------------------------------------|--------------------------------------|
| 6 mm | = 1.2 | 0.9 |
| 8 mm | > 1.2 to = 1.6 | 1.8 |
| 10 mm | > 1.6 to = 2 | 2.7 |

1.5 Frameless / Non-framed Glass:

In case of frameless or non-framed glass panel toughened safety or laminated safety glass only shall be used. The thickness of safety glass and corresponding maximum permissible area is given in the following table D.

Table D:

| Nominal Thickness (mm) | Maximum allowable area (sq.m.) |
|------------------------|--------------------------------|
| 6 | 3.0 |
| 8 | 4.5 |
| 10 | 6.0 |
| 12 | 7.5 |

In cases wherein the glass area exceeds 7.5 sq.m., it is not recommended to glaze the area or else determine thickness of the glass

using advanced analysis under wind load as per IS : 875 (part 3 1987; reaffirmed 1997) for external glazing and / or loads, in case of internal glazing or glazing wherein there are chances of human impact.

1.6 Point Supported glass:

It is not recommended for point fixed system unless the glass area and glass thickness is determined by the specific strength analysis and type of point fixing hardware.

2.0 Fixing glass:

Glass sheets may be fixed in wooden frame or metal frame. There is minor difference in the two cases. In wooden frame, rebates are provided in the glazing bar which support the glass pane, with the help of putty and beading. In some steel window frames the same may be possible, specially in smaller glazed areas, but in cases where extruded aluminum or steel sections are used for glazed walls, it shall not be feasible and special arrangements are available consisting of Shoe stop, storm clip, cover strip, lead wing, fixing bolt, drought excluder, PVC cushion etc.

2.1 The fixing of glass on wooden frame or some steel frames not using extruded sections is described below,

- a) Glass is fitted in the window over a thin layer of beading made with putty and back putty. In other words, the glass edges are embedded in putty. It seals the gap between the glass and the rebate in the glazing bar.
- b) The pane is secured by means of triangular pins, called 'Sprig' or panel pins to remain in position. In case of steel glazing bar, machine screws are fixed in the holes provided in the rebate to secure the glass.
- c) A wooden beading of appropriate size is fixed in front of the glass pane in the rebate in case of wooden frame. In case of steel frame, front putty is placed to form a triangular fillet with the help of knife blade. In case of wooden frame also, similar fillet can be placed by front putty instead of the beading. However, the finish is not very pleasing and is adopted for doors windows which do not come in the eyes of the occupants, such as for windows opening on the street on higher floors etc. but rarely used for doors. The details are shown in the figure below.

Glazing Putty (*Lambi*):

Putty is a mixture of linseed oil, white lead and chalk powder. It is in the form of thick paste. Boiled linseed oil is added to the above mixture to form a stiff paste of desired consistency. Readymade putty is nowadays available in the market under different brand names like Brite, Shalimar, Kumb etc.

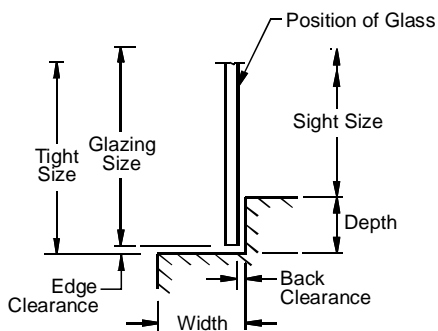
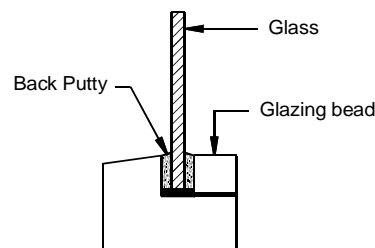
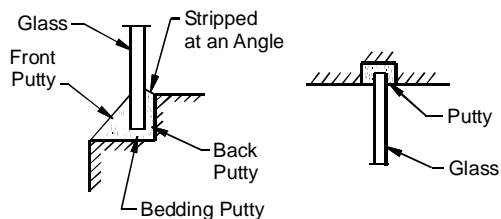
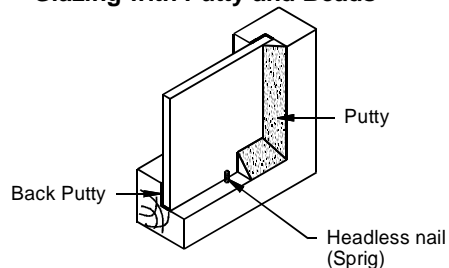
**Glazing Rebate****Glazing with Putty and Beads****Glazing with Compound****Glazing with Putty to Wooden Shutters**

Glazing Details

2.2 Putty for glass fixing: Following precautions should be taken while using putty for glass fixing:

- Mix the putty at site with the help of linseed oil and form a roll for better consistency.
- See that second coat oil paint is applied after semidrying of putty.
- Finishing of putty should be made smooth with the help of glass cut piece.
- See that sufficient quantity of putty is applied to every panel.
- Before applying putty, check that glazing clips are fixed in each and every hole provided in the frame.
- Position and tension of each glazing clip should be as such to hold the glass in position.
- Check that glass size is not under cut.
- Use glass diamond cutter to cut the glass of required size.
- Do not disturb the glass panes when putty is wet.

2.3 Glazed Walls:

The patented extruded aluminum and other metal sections are being used extensively in construction walls with glazing. This form of glazing has systems inbuilt for collecting and removing water in channels or glazing bars

different from putty and beading to seal the joints. Typical details are shown in the figure below.

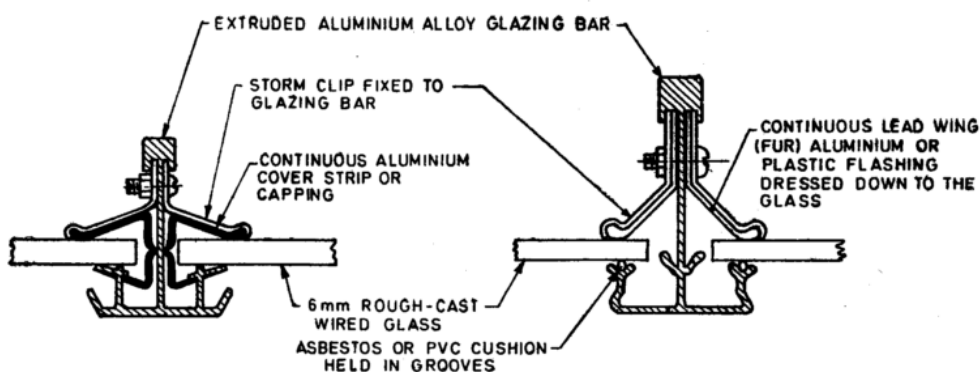

The various fixtures are required to be fixed as per the figure shown, however except for I.S.10439-1983 which also gives general specification, one has to go by the specifications provided by manufacturers of Aluminum doors and windows. Their brief function is as under,

- i. **Capping or cover strip:** It is a preformed metallic or plastic strip fitted externally to a glazing bar and prevents penetration of water and also restrains the glass from being lifted due to suction forces.
- ii. **Storm clip:** A fitting fixed externally to the glazing bar to restrain the glass against suction pressure.
- iii. **Draught excluder:** A strip to fill the space between the under side of glass and structural member to prevent penetration of driving rain or snow.
- iv. **Flashing:** A strip of flexible, impervious material usually metal or plastic used to exclude water from the junction between glazing and adjacent part.
- v. **Shoe Stop:** A fitting secured to the lower end of glazing bar and acting as a stop to the glass.
- vi. **Muntin section:** A light bar of suitable material, such as thin preformed aluminum strip or a plastic section in the shape of 'H' or 'Z' to weather horizontal butt joint between two panes of glass held vertically in the same plane by glazing bars.
- vii. **Lead wings:** A projection lead for forming an integral part of a glazing bar, it is dressed down to the glass to form a barrier against penetration by water.

The detailed assembly is shown in sketch below.

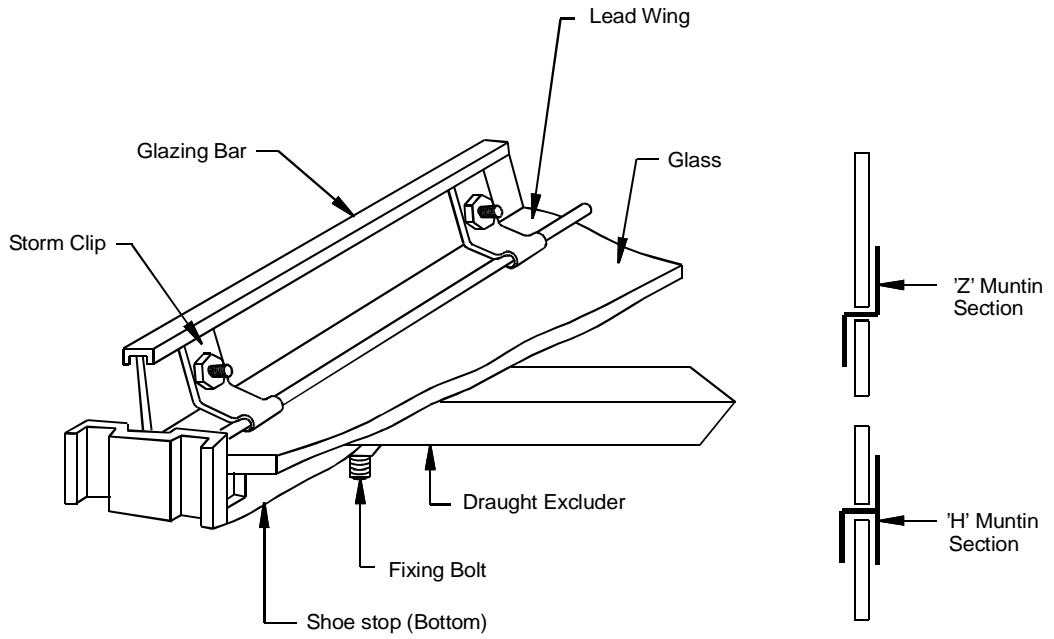

Chapter 8

SLOPE ROOF AND FALSE CEILING

1.0 Pitched or sloping roofs:

Sloped roofs are the oldest form of roofs in building, sheds and several temporary structures. The covering of shed roofs to match the triangulated support structure like trusses is normally done by tiles or corrugated Galvanized sheets or Asbestos cement corrugated sheets. These days awareness is growing about effects of components of Asbestos on the workers handling the manufacture of these sheets and several other types of sheets such as Aluminium corrugated sheets, stainless steel corrugated sheets are being used. Apart from the different material and process of manufacture, the method of making the support structure and fixing the sheet remains mostly same.

1.1 Various components of slope Roofing:

Barge boards - Boards mounted under the roofing at a gable end - traditionally timber, nowadays usually UPVC. These are generally mounted flush on the end wall. It is about 250mm wide and 25mm thick.

Dormer - A vertical window built into the slope of a pitched roof.

Eaves - The overhung area just below the lower end of the roof on the outsides of building - includes the fascia, soffit and guttering. The eaves board is about 250mm wide and 25mm thick, it is made in timber, however in AC sheet roofing, the board is made of AC sheet.

Fascia - The vertical board secured to the ends of the rafters under the lower end of the roof to which the guttering is normally fixed - traditionally timber, nowadays usually AC or PVC is used.

Flashing - A weather seal, usually made of A.C. sheet, Galvanised iron sheet is fixed where part of the roof abuts a vertical surface - one side of

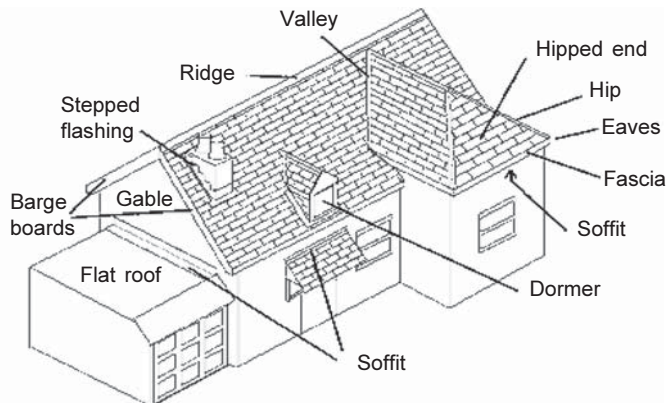

the flashing is normally embedded in a joint between two rows of bricks, the other side being shaped to fit onto the roof surface. Plain flashing is where the roof meets the vertical surface horizontally. Stepped flashing is where the roof meets the vertical surface at an angle - the steps in the flashing align with the joints of different courses in the brickwork

Gable - The vertical wall at the end of a pitched roof, is like an inverted 'V'.

Hip - A sloping ridge formed by the junction of a pitched roof and a hip end.

Hip board - The board along the line of a hip from the fascia to the ridge of the pitch.

Hip end - A sloping end to a pitched roof which is covered with tiles or sheets.

Rafter - A vertical, sloping timber or steel angle used to form the shape of the roof - the side of a truss.

Purlins : The horizontal member between the spacing of rafters, supporting and holding roofing material like G.I. sheets, A.C. sheets etc.

Ridge - The horizontal line at the top of a pitched roof - applies whether there is a sloping roof on both sides (a Duo ridge), or if there is just one (a Mono ridge).

Ridge board - The horizontal board along the line of the ridge - normally along the top of the rafters or trusses.

Soffit - The horizontal board used to seal the space between the back of the fascia and the wall of the building - traditionally timber, or Asbestos cement board nowadays PVC with air vents is also used.

2.0 Trusses:

A triangulated truss structure is generally used for long spans. However, light trusses work out cheaper than beams even for small span of 3.6m and above. The spacing of trusses depend upon the load of roof, position of cross walls, span and material of truss. Some of the usual trusses are given below.

2.1 King-post truss:

In this type of truss, the vertical central post is known as King post. The Tie beam is the horizontal member at the bottom of the truss. King post rests on the tie beam. The inclined members known as struts, which divide the span of the principal rafter, thus prevent it from becoming beam. Normally, King-post trusses are used up to the span of 9m. The figure below shows the details of the King-post truss.

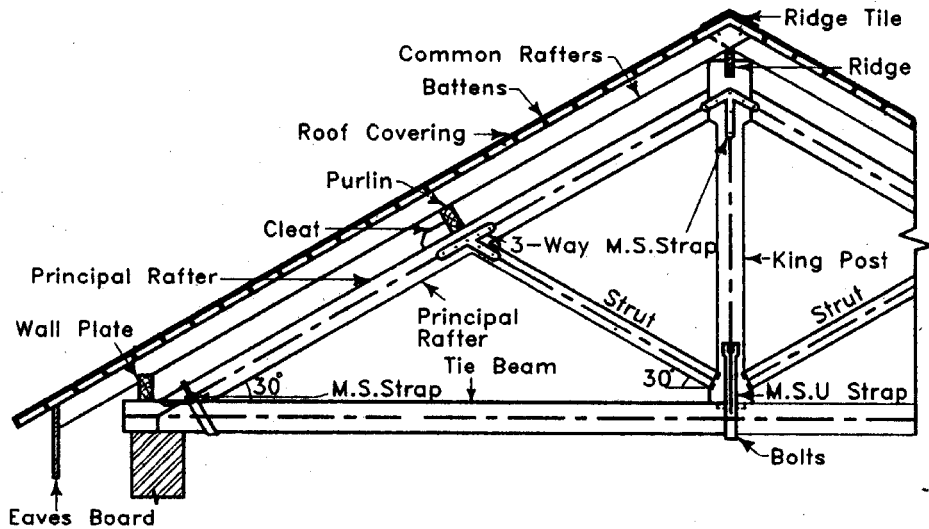

King-Post Truss

If the truss is made from hard wood, the sizes of various components are adopted as per the table below.

| No. | Span m | Members | | | | | | | |
|-----|-----------|----------------|-----|-----------------|-----|-------------|-----|---------------|-----|
| | | King-post (mm) | | Principals (mm) | | Struts (mm) | | Tie Beam (mm) | |
| | | D | B | D | B | D | B | D | B |
| 1 | 3.60 | 80 | 80 | 130 | 80 | 70 | 80 | 130 | 80 |
| 2 | 4.20 | 80 | 80 | 140 | 80 | 70 | 80 | 130 | 80 |
| 3 | 4.80 | 90 | 80 | 150 | 80 | 70 | 80 | 130 | 80 |
| 4 | 5.40 | 90 | 90 | 150 | 90 | 70 | 90 | 140 | 90 |
| 5 | 6.00 | 90 | 90 | 180 | 90 | 80 | 90 | 150 | 90 |
| 6 | 6.60 | 100 | 90 | 190 | 90 | 80 | 90 | 160 | 90 |
| 7 | 7.20 | 100 | 100 | 190 | 100 | 80 | 100 | 160 | 100 |
| 8 | 7.80 | 100 | 100 | 200 | 100 | 90 | 100 | 180 | 100 |
| 9 | 8.40 | 100 | 120 | 200 | 120 | 90 | 120 | 180 | 120 |
| 10 | 9.00 | 100 | 120 | 210 | 120 | 90 | 120 | 190 | 120 |

2.2 Queen-post truss:

This type of truss has two vertical post known as Queen-posts placed at $\frac{1}{3}$ rd length of the beam from either ends. The upper ends of the queen posts are kept in position by means of a horizontal member known as 'straining beam'. A 'straining sill' is also placed on the tie beam between the queen-posts to counteract the thrust of struts. This form of truss is used for longer span and generally up to 15m. The below given figure shows the details of the queen-post.

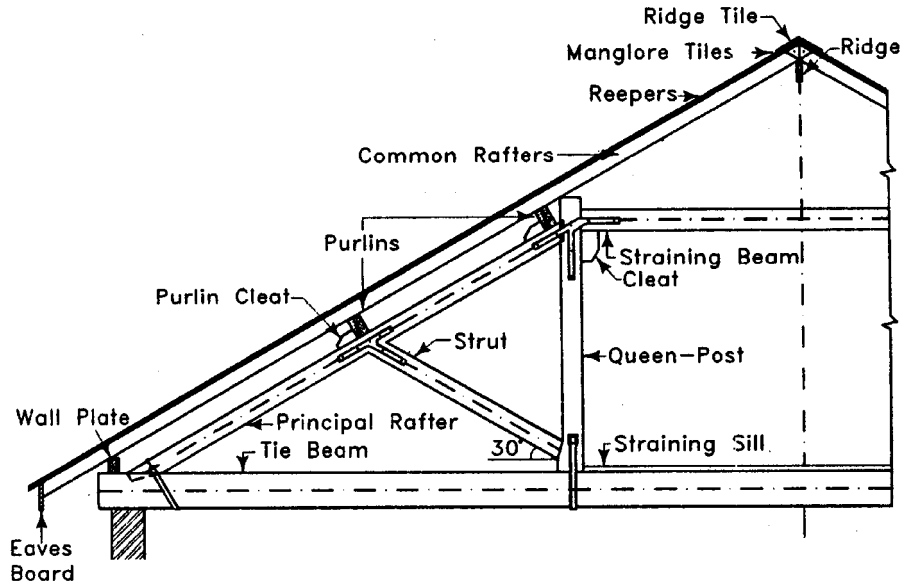

Queen-Post Truss

If this truss is made by hard wood, the approximate sizes of various elements are as under.

| No. | Span m | Members | | | | | | | |
|-----|-----------|----------------|-----|-----------------|-----|-------------|-----|---------------|-----|
| | | King-post (mm) | | Principals (mm) | | Struts (mm) | | Tie Beam (mm) | |
| | | D | B | D | B | D | B | D | B |
| 1 | 7.80 | 130 | 100 | 200 | 100 | 70 | 100 | 180 | 100 |
| 2 | 8.40 | 130 | 120 | 200 | 120 | 70 | 120 | 180 | 120 |
| 3 | 9.00 | 140 | 120 | 210 | 120 | 70 | 120 | 190 | 120 |
| 4 | 9.60 | 150 | 120 | 230 | 120 | 70 | 120 | 190 | 120 |
| 5 | 10.20 | 150 | 120 | 240 | 120 | 70 | 120 | 200 | 120 |
| 6 | 10.80 | 150 | 120 | 240 | 130 | 80 | 130 | 200 | 130 |
| 7 | 11.40 | 160 | 130 | 240 | 130 | 80 | 130 | 200 | 130 |
| 8 | 12.00 | 160 | 130 | 250 | 130 | 90 | 130 | 210 | 130 |

2.3 The details of the joints used in wooden trusses are shown below:

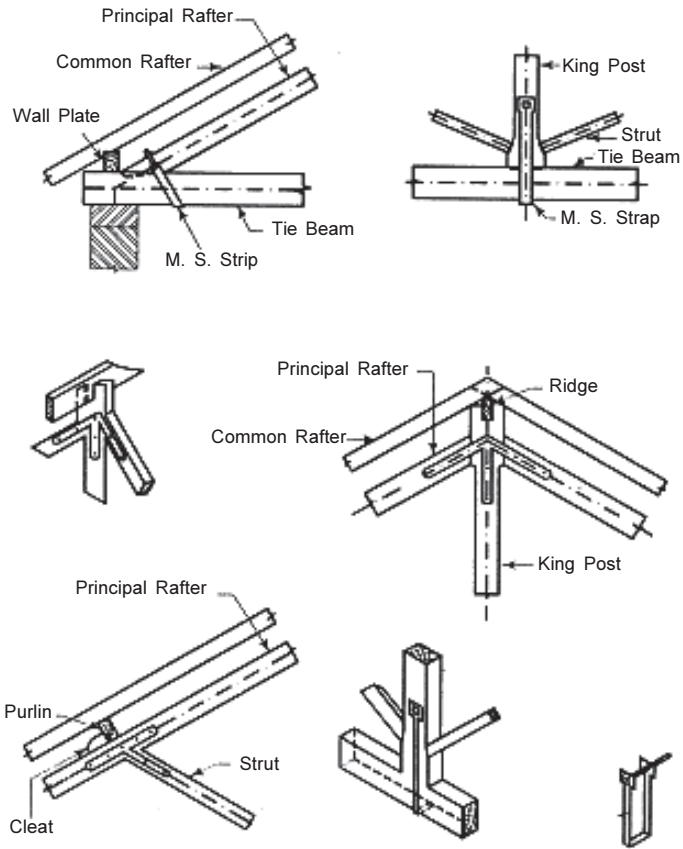

Details of Joints of the Queen-post trusses

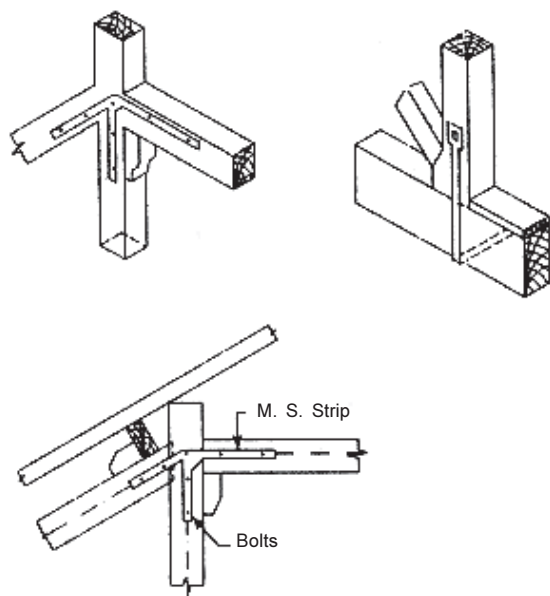

3.0 Spacing of purlins:

Wooden or steel purlins, as per design, are fixed over the rafters spacing the consecutive trusses. The spacing of purlins are so decided that each support point on roof receives one purlin and additional purlins may be required to suit the length of sheets. The spacing of purlin shall not be spaced at more than the following distances for different thicknesses of A.C. and CGI sheets:

Spacing for A.C. sheet

| Thickness of A.C. sheet | Distance between Purlin Centres | |
|-------------------------|---------------------------------|-------------------|
| | For roof covering | For side cladding |
| 4 mm | 0.8 m | 1.35 m |
| 6 mm | 1.4 m | 1.70 m |

Spacing for CGI Sheet:

| Spacings of Purlins | Thickness of CGI Sheets |
|---------------------|-------------------------|
| 1.60 metres | 0.63 mm - 24 gauge |
| 1.80 m | 0.80 mm - 22 gauge |
| 2.00 m | 1.00 mm - 20 gauge |
| 2.40 m | 1.25 mm - 18 gauge |
| 2.80 m | 1.60 mm - 16 gauge |

If the smaller sheets are available and accordingly purlin spacing is required to be smaller, it should be done near the eaves, as more strength is required at this location.

4.0 Corrugated Galvanized Iron Sheet / A.C. Sheet Roofing:

Sloped roof coverings using galvanized steel sheets or A.C. sheets are generally used for storage sheds, godowns and factory buildings besides their extensive use in remote areas. These are easy and quick to erect and economical.

4.1 Slope: Slope of the CGI / A.C. sheet roofing is normally 1:3 and should not be flatter than 1:5.

4.2 Overlap: The A.C. Sheets are laid with a minimum end lap of 150 mm, generally it is kept as 200 mm, side lap of half corrugation. In the CGI sheet roofing the end lap is same as A.C. sheet i.e. minimum 150 mm. but the side lap should be minimum two ridges of corrugations at each side. The minimum lap of sheets with ridges, hips and valleys should not be less than 200 mm.

4.3 Size of Sheets:

The CGI sheets are available in the width of 910mm and various lengths like 2.44m, 3.05m, 3.66m, 4.27m and 4.88m. The thickness of the

CGI sheet available for use of roofs varies from 0.63mm to 1.60mm (24 gauge to 16 gauge).

The A.C. sheets are available in the width of 1065mm and length varying between 1980 to 3050mm as per table below.

| Sizes | Thickness |
|-------------|-----------|
| 1980 x 1065 | 5 mm |
| 1980 x 1065 | 6 mm |
| 2440 x 1065 | 5 mm |
| 2440 x 1065 | 6 mm |
| 3050 x 1065 | 5 mm |
| 3050 x 1065 | 6 mm |

5.0 Laying of corrugated sheets:

This procedure is applicable to CGI as well as A.C. sheets.

Choosing Correct size of sheet:

Step – 1:

The size of sheet should be selected as per the inclined length of the roof and spacing between the purlins. Overlap and projection over the wall, also needs to be considered.

Step - 2:

Top surface of the purlins should be painted before sheets are fixed. Embedded portions of wooden purlins should be coal-tarred by two coats.

Step – 3:

Decide the projection of sheets over the front wall. The unsupported length of overhang should not exceed 300mm.

Step – 4:

Then a line dori should be stretched horizontally, on the projection line of sheet, between first and last rafter parallel to front wall and perpendicular to the rafter.

Step – 5:

In case of A.C. sheets wherever four sheets join at a corner (at the overlap corner) mitring of corners is necessary, to provide a snug fit. Mitred corner is a triangular cut at the end of sheet equal to length of end lap and width of side lap. The cutting of corners should always be done on ground by hack-saw. A complete sketch should be made out, working out; the sheets and their corners to be mitred. This is very important or else, leakage from such joint can be a chronic problem.

Step – 6:

The work of laying sheet should be commenced by laying the bottom sheets first and then work up towards the ridge. The laying of sheet should start from the side away from wind direction so that the side laps will come opposite to regular wind direction and wind will not enter in the gap. In the A.C. sheet smooth side of sheet should be kept on the up side. The overlaps are kept as mentioned earlier for each type of sheet.

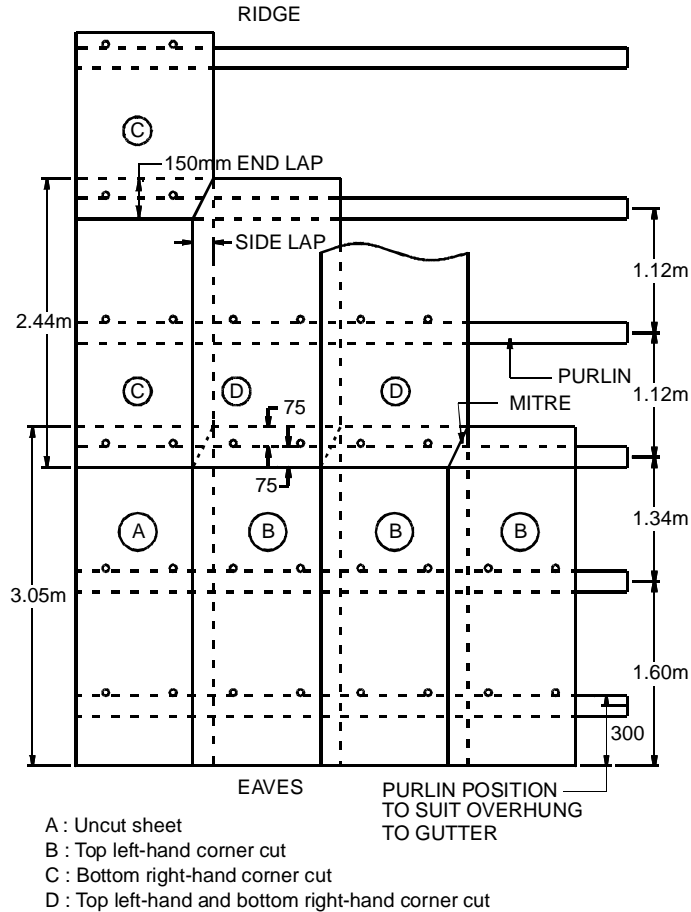

A.C. Sheet Layout with Mitre

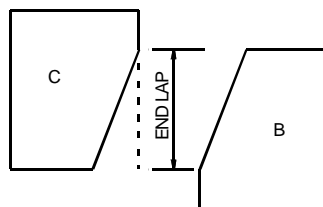

Cutting Mitre to A.C. Sheets

Step – 7:

Holes in CGI and A.C. sheets shall be drilled and not punched on the ridge of the corrugations. The holes should be made from bottom side and not from the top of roof so that the line of purlins will be matched and there will be no gap or mismatch between hole and purlin edge. The hole drilled from top can also cause a source of leakage. The holes in the sheet, holes of the washers shall be of the exact diameter of the hook bolts, maximum 2mm bigger dia hole in the sheet and washer is allowed than the dia of bolt. The nuts shall be tightened from above. No hole should be within 75mm from the edge of sheet and maximum spacing between two hook bolts should be 300mm.

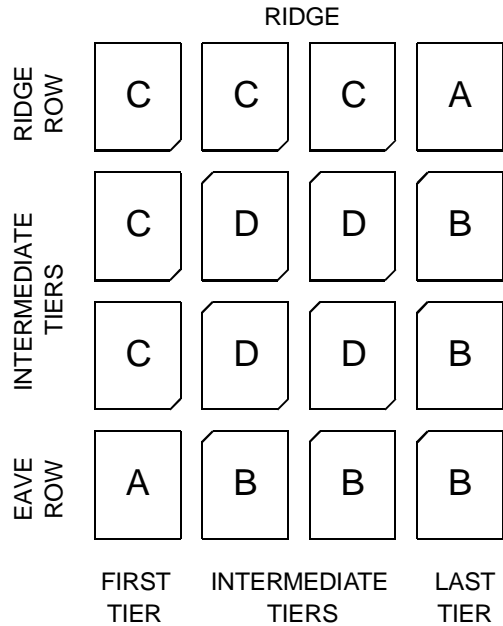

Step – 8:

Sheets shall be fixed to the purlins or other roof members such as hips valley rafters, with galvanized ‘J’ and ‘L’ hook bolts and nuts, 6mm or 8 mm dia bolt with bitumen washer of 35mm dia and Galvanised Iron ‘limpet’ (dome) washers of 25mm dia. The diameter of bolt is depending on the spacing of purlins, 6mm dia bolts can be used for up to 1.8m spacing of purlins and 8mm dia bolt be used for spacing more than 2m. The ‘J’ hooks are used for fixing sheets on iron (MS) angles and ‘L’ hooks are used for RS Joist, MS Channel and wooden members. The length of the ‘J’ or ‘L’ bolt should be 75mm longer than the height of purlin in case of single sheet fixing and 90mm longer than two sheets (laps) fixing. However, after fixing the bolt it should project above the top of their nuts not less than 12 mm. In CGI sheets length can be reduced to meet this requirement. The grip of J or L hook bolts on the side of the purlins shall not be less than 25 mm. The bolt should have exact width at the bottom of hook equal to the size of purlin so that it will fit into the purlin. The bolt should be fixed on the ridges of the corrugations of the sheet. There shall be minimum three hook bolts placed in each sheet on every purlin and their spacing shall not exceed 30 cm. Wood screw shall not be used for fixing sheets to purlins.

5.1 Special Conditions:

1. Wherever gables or parapet or wall is existing at the end, the sheet shall not be built into gables and parapets. The sheets shall be bent up along their side edges close to wall and the junction shall be protected by suitable flashing or by a projecting drip course (wata / gola), the latter to cover the junction by at least by 75 mm.
2. If there is break in the level of roof i.e some valley ridge may have to be introduced in the roof, the G.I. plain sheet gutter should be fixed below roofing sheets in addition. The G.I. sheet is bent to proper shape and then fixed below roofing sheet. The overlap of G.I. sheet should not be less than 250mm on either side. The rain water coming from the roof sheets will properly flow down to the gutter.

The roofing sheets should be cut as per the angle subtended on the roof due to valley. The special attention should be given to fixing sheet to valley to prevent leakage.

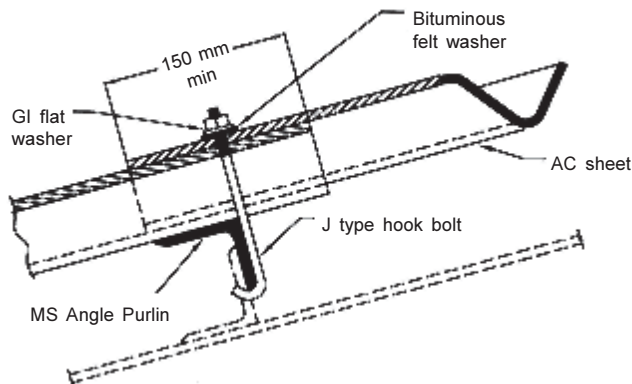

Details of end lap

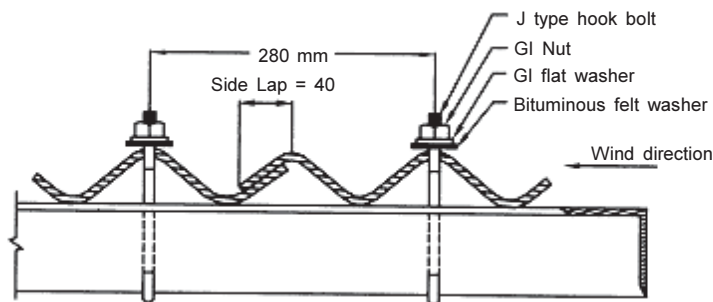

Details of side lap

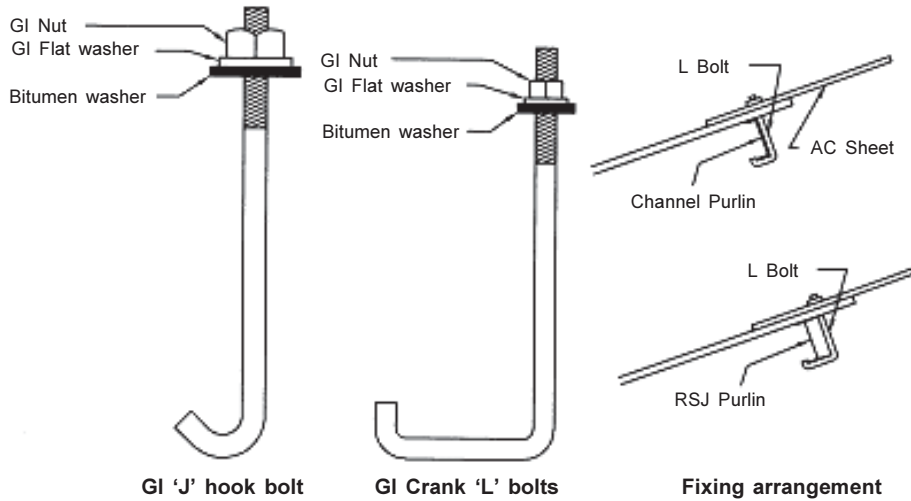

Hook Bolts

5.2 Fixing of Ridges and Gutters:

a) Ridge :

The ridge is the apex part of the sloping roof. The both side sloping panels are joining at the ridges. For the A.C. Sheet roofing serrated adjustable type ridges are available in pairs as inner and outer ridges as shown in figure. For CGI sheet roofing the ridges should be made with minimum 18 gauge GI sheet. The GI sheet ridge is shown in figure.

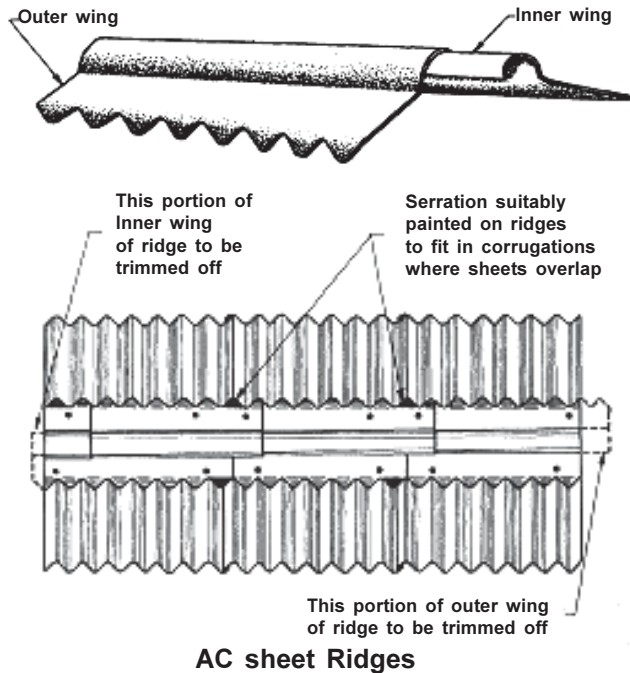

The ridge hips should be covered with ridge and hip section with a minimum overlap of 150mm on both side of roofing sheet. The end laps of ridges and hips, and between ridges and hips also not less than 150mm.

b) Gutters:

Gutters are provided to collect and carry rain water coming from roof and put it in the down take pipe. The gutters are laid in the slope of 1 in 120.

The gutters are made up of plain A.C. and G.I. sheets. Generally the G.I. gutters are half round in shape. It is readily available in the diameter size of 150mm, 225mm and 305mm. The following shapes are available in A.C. gutters.

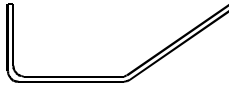
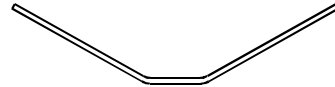
**Half Round Gutter****Eaves Gutter****Valley Gutter****Various shapes of A.C. gutters**

The gutters are supported with the bracket. The brackets are made of M.S. flat 40 mm wide and 3 mm thick. The brackets are fixed to the rafters at one end with nut bolts and other end has shape according to the shape of gutters. The slope in the gutters shall be given in the line of supporting brackets. The brackets shall be placed at not more than 90cm. The bracket is twisted at the neck as shown in figure.

The gutters are laid in the slope of 1 in 120. The clamps are provided at the distance of 900mm with the slope of 1 in 120 as shown in the figure. The clamps should be placed at the distance 900mm and 7.5mm below the previous clamp to achieve the slope of 1 in 120. For any further minor adjustment, the gutters can be raised to achieve proper slope by providing steel packing plates duly tack-welded to the clamps below the gutter.

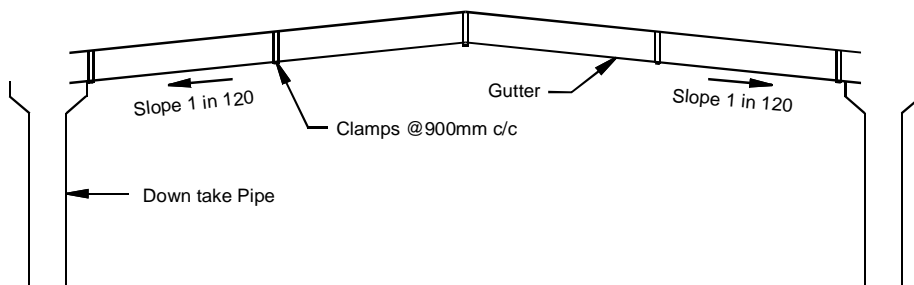
**Fixing gutters with slope**

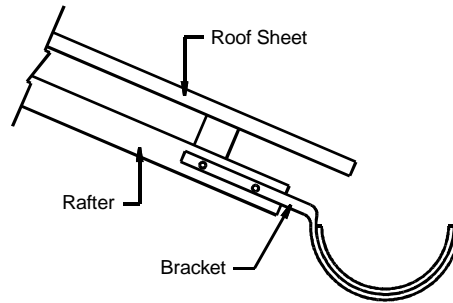

Clamp / Bracket

The down take pipe from the gutter to the outlet drain on ground, needs special attention and should be fitted using funnel shape connection piece as shown in figure below.

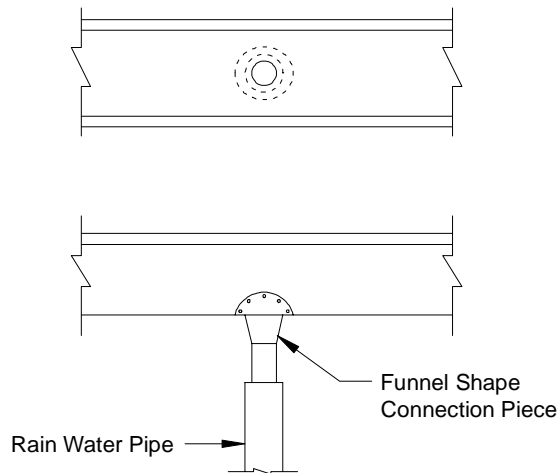

Gutter connection to Rain Water Pipe

c) Wind Ties:

In coastal areas and other storm affected areas a steel flat of 50 x 6mm is fixed over the length of the roof both sides. The wind tie is fixed closer to eaves. The M.S. flat is fitted to first and last purlins with the same hook bolts which are holding the sheets.

6.0 False ceiling:

6.1 General:

The false ceilings are required for different reasons, namely, i) in sloping roofs, to provide a flat and even appearance and prevent birds to sit

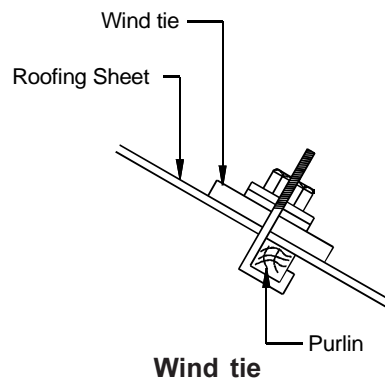

Wind tie

and nest, ii) To improve accoustics of the room, hall, iii) To reduce volume of air conditioning in case of high rooms iv) To reduce heat conduction from flat roofs or v) to cover electric cables, wires and other service pipes etc.

All false ceilings are suspended from the roof, by means of steal wire, or steel strips. The system of framing, suspending, and fixing of frame is similar except the tile material and the material used for the frame. The choice of covering/filling material depends on several considerations like:

- a) Aesthetics
- b) The purpose for use
- c) Availability and cost

6.1 Types of false ceiling:

1. Hessian cloth false ceiling
2. A.C. Sheet False ceiling
3. Particle Board false ceiling
4. Gypsum Board False ceiling
5. Straw Board False ceiling
6. PVC False ceiling

6.1.1 Hessian Cloth False Ceiling:

This is cheapest and functional, type of false ceiling and is provided under sloped roofs, of wooden trusses. Here the frame is nailed on the bottom beam of the trusses or hung to the rafters. Hessian cloth is normally available in a roll of width of 36" (915mm), 45" (1140 mm) and 50" (1265 mm). The cloth should be 'real selfedged' on both sides. For a frame of 1200 mm grid, choose the cloth of 54" width. The Hessian cloth quality is measured in weight (Ozs.). Proper quality for ceiling is cloth of weight, 7 oz. per sq. yard. The cloth is available in rolls and is stretched from end to end of the room in one panel of 1200 mm width. This way the whole room is covered. The cloth is nailed to the frame. A wooden beading of 25x12 mm is nailed. At the cut end/side of the cloth, an additional length of 50 mm and at 'selfedges', 25 mm, is taken which is folded in two layers of 25 mm, and one layer respectively, and nailed. The cloth is given 3-4 coats of lime wash, till it gets a smooth finish.

6.1.2 A.C.Sheet False Ceiling:

Asbestos cement plain sheets are light and provide good heat insulation and are fire proof. On painting they get good smooth and shining surface and are therefore a good and cheap material for false ceilings. They are available in sizes 1200x1200 mm, 1200x1800 mm and 1200x2400 mm sheets and in two thicknesses 4mm and 6 mm. The panel size of 1200x1200mm should be chosen for ceiling and any of the sheets with 4mm or 6 mm thickness can be used on steel or aluminum frame. However, if

panels are chosen bigger than 1200x1200, or they are to be fixed on wooden frame, 6 mm sheets only be adopted. The joints are covered with a wooden bead of size 25x 12 mm.

6.1.3 Particle Board Ceiling:

Particle boards can take very good polish and can be laminated also. They also do not conduct heat and as such protect against heat radiated from the roof. They are available in sizes 1220x2440 and panels of 1220x1220 mm can be conveniently provided.

6.1.4 Gypsum Board False Ceiling:

Gypsum board ceilings are provided mostly when the false ceiling is to be covered by P.O.P. This is good insulator of heat and is suitable for air-conditioning requirements. These are available in tiles of 600x600 mm and accordingly the frame has to be made with grid of matching size. Prior to adopting Gypsum board for false ceiling the water proofing of the roof should be doubly checked, as these boards get spoiled by coming in contact with water.

6.1.5 Straw Board False Ceiling:

Straw Boards are comparatively light and are also considered better for acoustic improvement, due to their rough exterior. These are also spoiled by coming in contact with water and leakage of roof if any should be thoroughly attended.

6.1.6 P.V.C. False Ceiling:

PVC Ceiling has various advantages over other materials namely they are waterproof, Termite Proof, Fire Retardant, Economical, Maintenance free, and is available in various colours shades without any need of Painting & Polishing. These are being manufactured under several trade brands and are supplied along with extruded channels and other sections in P.V.C. for frames.

6.2 Types of Frame:

6.2.1 Steel or aluminum frame:

The frame work for false ceiling is normally made of Galvanized steel 'T' section or suitable Aluminum 'T' section, kept upside down. The load of the frame as also the tiles/panels etc. is primarily taken by the suspenders and the frame provides means of seating the tiles only and support partially, the dead load of tiles, between two suspenders. Normally the tiles/boards are commercially available in size of 600x600 or 1200x1200 mm and accordingly the frame has to be made with a grid size of 600x600 mm or 1200x1200 mm. The frame is hung to the main roof from the suspenders fixed to the original ceiling and also fixed to the wall. Rolled Aluminum 'T' section of 38x38 mm with a thickness 3.1mm @ 3.45 Kg/m weight, should normally be

used. Steel 'T' section of 40x40x3 mm can also be used. The frame is suspended on level adjusting hangers of 2 mm diameter galvanized M.S. wire spaced at a distance of 1200mm center to center, fixed to roof by means of galvanized expansion hold fasteners or hooks 4 mm diameter. The entire frame and angles shall be provided with approved preservative coat, in case M.S. angles and 'T' are used. The wire, fasteners should be galvanized for protection against corrosion. This is very important, as the humidity above the false ceiling is substantial and false ceiling are known to have sagged due to corrosion of the suspender elements. The 'T' sections are also supported on the equal angle 40x40x3 mm fixed all around wall, at a decided level, depending upon the height of false ceiling to be kept.

The main 'T' should run in the shorter dimension of the room, and the cross 'T' is fixed between the two main 'T' member using metal screws fixed on the vertical leg of the two 'T's, through a right angle cleat made from a flat of 15x3 mm. The length of the legs of the cleat is 50mm.

6.2.2 Wooden frame:

Any hard wood like Teak, of 40x25 mm size should be used for making the frame. The runner on the walls, replacing the angle, can be 25x40 mm. The joints and the nails/screws are covered with wooden beading of 25x12mm, with wood screws. X-joint is provided at the junction of main and cross battens.

6.2.2.1 Fixing of AC Sheet and Hessian Cloth on Wooden Frame:

All fixing on wooden frame is done from underside as opposed to Aluminum or steel frame. The fixing is carried out with nails/ wood screws, as required for strong and durable fixing. The Hessian cloth is fixed with Tach nails and the A.C. sheets are fixed on the frame with counter sunk wood screws to the underside of the frame. Where joints are to be covered, the tiles/boards may be spaced 3 to 4 mm. apart. In case the boards, where joints are to be left exposed, the sheets should be butt laid with their edges abutting in moderate contact, but without having to force them into place. For the exposed joints, the outer rows of the screws are placed at 10cm centers and about 12mm from the edge of the sheet. The nails should be counter sunk in the under side of board with a suitable punch. Care shall be taken in driving the nails so that the sheets are not marked by hammer blows.

In the outer rows at edges to be covered by beadings, the screws will be spaced at 20cm centers in each row but with the screws staggered. The beadings will then be fixed over the sheets with screws at 20cm centers in each row with the screws in the two rows staggered and passing through beading, sheet and framing so that ultimately the spacing of the fixing (nails and screws taken together) in each row will be at 10cm centers so far as the sheets and frames are concerned.

6.2.3 Finishing:

The exposed side of the board shall be truly level and plane without any local bulges or sags. The joints shall be truly parallel and / or perpendicular to the walls. The width of joints shall be uniform. Care shall be taken to see that the uniformity of colour of the sheets is not spoiled during the fixing operations.

Where the joints are required to be covered, beadings of uniform size, pattern and material shall then be fixed with screws.

6.3 Process for installation of Aluminium False Ceiling:

- Planning for a Suspended Ceiling
- Installing Wall Angles
- Locating and Hanging Suspension Wires for Main 'T's
- Installing Main 'T's
- Installing Cross 'T's and Border Cross 'T's
- Installing Ceiling Panels

Step 1 : Planning for false ceiling:

- First, get the exact measurements of the room where the suspended ceiling will be installed. Use special care in measuring any odd-shaped alcoves, bays, etc.
- Draw the exact dimensions to scale on graph paper (Fig. 1) Then estimate the material required.
- Any pattern of 600x600 mm, 600x1200 or a 1200x1200 mm, pattern (Fig. 2) should be selected. The pattern which is selected will determine the material requirements for the ceiling.
- For the 600x1200 pattern, decide to install the patterns in a standard or reverse pattern (Fig. 3). Each pattern offers a different appearance.
- According to the decision, sketch the layout for the planned ceiling on graph paper. One can use the layout in Fig. 1. Position the 'T's so that the border patterns at the room edges are equal on both sides and as large as possible. Attempt should be to get end panels more than half the tile/panel.
- It is important to space the cross 'T's so the border panels at the ends of the room are equal and as large as possible. If you are using a 600x1200 mm pattern, main 'T's will be 1200 mm apart and the cross 'T's will be 600 mm apart. For a 600x600 mm pattern, main 'T's and cross 'T's shall be at 600 mm apart (Fig. 2).
- If the ceiling will be recessed and built-in lighting will be installed, decide where to locate the panels of light and clearly identify them on the drawing.

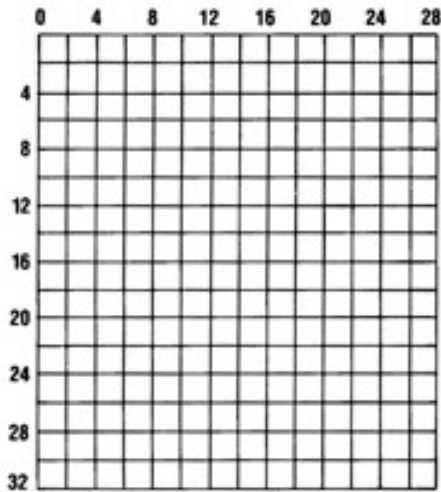

FIG. 1 - Sketch the room dimensions to scale here.

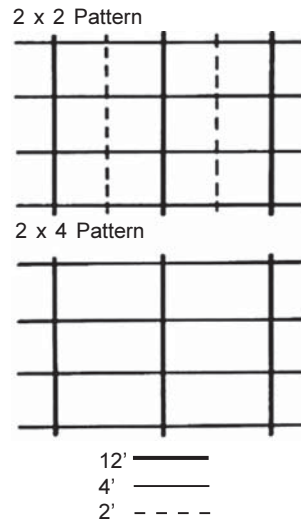
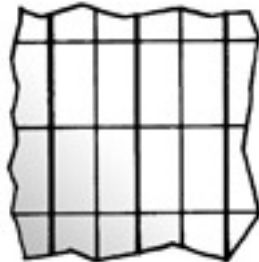

FIG. 2 - Select the grid pattern to be use.

Standard (panels parallel to short dimension)



Reserved (panels perpendicular to short dimension)

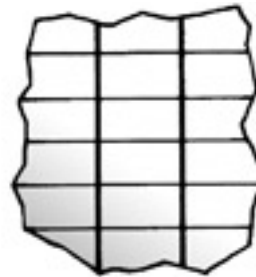

FIG. 3 - If 2x4 panels are used, choose from either a standard or reversed pattern.

Step 2 : Installing wall angles:

- Determine the exact height at which the suspended ceiling will be installed. Allow a minimum of 75 mm to 100 mm clearance between the existing ceiling and the new false ceiling for installation of the ceiling panels. Additional clearance will be required if light fittings are using recessed in the false ceiling (Fig.4). The ceiling should however be not lower than 2600 mm.
- After locating the exact position for the suspended false ceiling, draw a line with using water tube level, completely around the room indicating where the wall angle will be applied (Fig. 5). Don't assume

the original ceiling is level, use a water level tube for accuracy..

- Fix the wall angles securely to the wall at all points. Nail them firmly to studs, or use screw anchors or other masonry fasteners on brick or masonry walls (Fig. 6).
- Position the wall angle so that the bottom flange rests on the level line drawn on the wall.

Overlap the wall angle on inside corners (A, Fig. 7), and miter the wall angle on outside corners (B, Fig. 7). Cut any needed angles with metal cutting snips or a hacksaw.

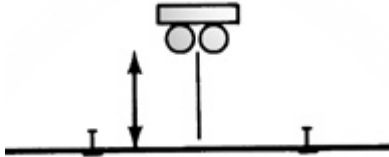

FIG. 4 - Allow a minimum of 6" space between the ceilings if recessed lights are to be fixed to false ceiling.

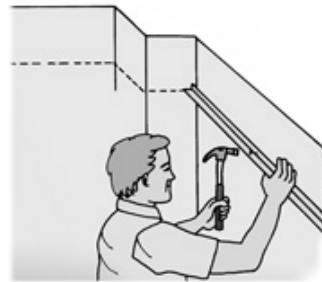

FIG. 5 - Use a level to apply the wall angle at a proper height around the room.

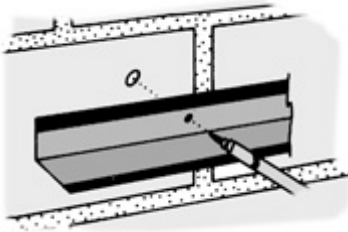

FIG. 6 - Fasten the wall angles securely to the wall at all points.

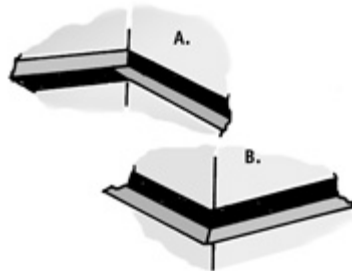

FIG. 7 - Overlap the inside corners and miter the outside corners.

Step 3 : Locating & hanging suspension wires for main 'T's:

- If recessed light fittings to use in false ceiling, install the wiring before putting the suspension wires in place .
- For recessed lighting, 600x600 mm or 600x1200 mm drop-in lighting fixtures can be used, which are specially designed for this purpose. One can also use center fluorescent light fixtures over the panels and additional cross 'T's will have to be fixed in the frame matching the light fixtures if the fixtures are smaller than the standard panel size.

Depending on the weight of the light fixture, one may decide to strengthen the suspenders near the fixture.

- Refer to sketch of the room for the location of all main 'T's (Fig. 1). Main 'T's should always run at right angles to the longer side of the room.
- Locate the position of each main 'T' by stretching a tight line *dori* from the top edge of the wall angle on all sides of the room at each position where the main 'T's are to be placed (Fig. 8).

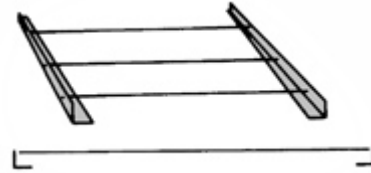

FIG. 8 - Stretch a tight line from the top edge of the wall angle on all sides of the room at each position where the main 'T's are to be placed.

- Fix expansion hold fasteners on the original ceiling, at the junction of main 'T' with cross 'T' at 1200 mm spacing in both directions, the first one being at first row of junctions, which may be less than 1200 mm. Drill a 3.15 mm diameter hole in the vertical leg of the main 'T' at each junction for fixing the suspender wire.
- Cut the suspension wires to the proper length. The wires should be 300 mm longer than the distance between the old ceiling and the new guideline string stretched to indicate the position of each main 'T'.
- Locate the first suspension wire for each main 'T' directly above the point where the first cross 'T' meets the main 'T'. Check the original sketch of the room to determine this location.

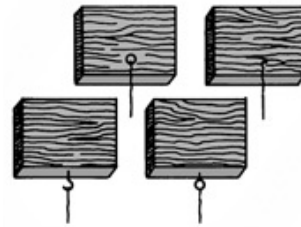

FIG. 9- Be sure the suspension wires are securely fastened to the roof beams or in case of RCC roof, expansion hold fastner is used after drilling in concrete roof.

- Be sure the suspension wires are securely fastened. Apply them to the ceiling

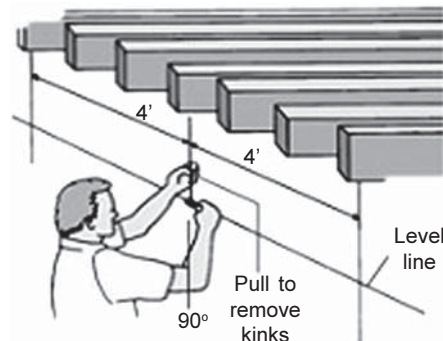

FIG. 10 - Add a suspension wire every 4' along the level line and bend at a 90° angle

with drilling and using expansion hold fasteners (Fig. 9).

Attach a suspension wire every 1200 mm along the level guideline (Fig. 10). Stretch each wire to remove any kinks and make a 90° bend where the suspension wire crosses the level line.

Step 4 : Installing main 'T's:

- 38X38x3 mm Aluminum 'T' sections are available in lengths of 5.85 m and should not be required to be extended in most cases. If required they can be spliced using a splice plate of 1.8 mm from both sides duly fixed by counter sunk metal screws, alternately from either side.
- Cut the 'T' equal to the width of the room where the main 'T' will span. The length should be reduced by 6 mm to account for thickness of wall angles.
- The head of 'T' is cut for a length of 37 mm on both ends by hack saw, to leave the web only intact to sit on the angle evenly as seen from the inside the room. Gas cutting can also be done but the welder should be skilled to obtain a perfect straight and even cut.
- Two no. holes of 3.15 diameter are drilled at the sawn stub at each end to receive the cleat as described below.
- Mark the junction points with cross 'T' on the full length of main 'T'. Fix a cleat (100x20x3 mm, strip bent at 90 degrees to give an angle cleat 50x50x3 mm and 2 holes are drilled on both legs suitable for 3.15 mm metal screw) at each junction point on one side, staggered from center line, by 1.6 mm, to accommodate the cross 'T'. Similar cleat is to be fixed on other side of vertical leg of 'T' to receive cross 'T' from adjacent panel. Each cleat is to be fixed with 3.15 mm metal screws. Similar cleat is also fixed at the two stub ends of the main 'T'. A 3.15 mm diameter hole is drilled on the vertical leg of main 'T' between the two cleats 10 mm below the top, to receive the suspender wire.
- Install the main 'T' on the wall angles and simultaneously fixing the suspenders.
- Install the main tees so that they are all level with the wall angle already mounted. Use a long level for this.

Step 5 : Installing cross 'T' & Border cross 'T'

- Cross 'T' are prepared by cutting to correct size after measuring the actual spacing of the main 'T's. Drill two holes at both ends at the appropriate location to fix with the cleat on the main 'T'.

Border cross 'T' are installed between the wall angle and the last main tee.

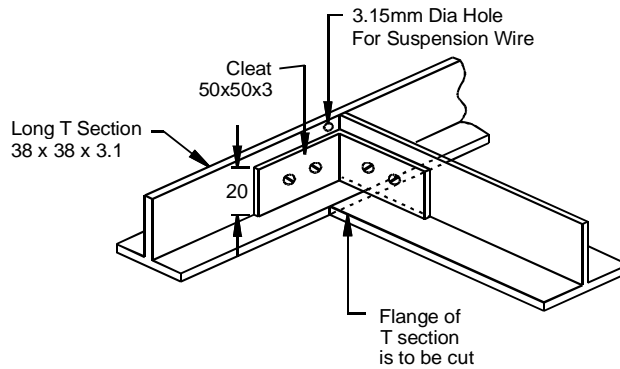
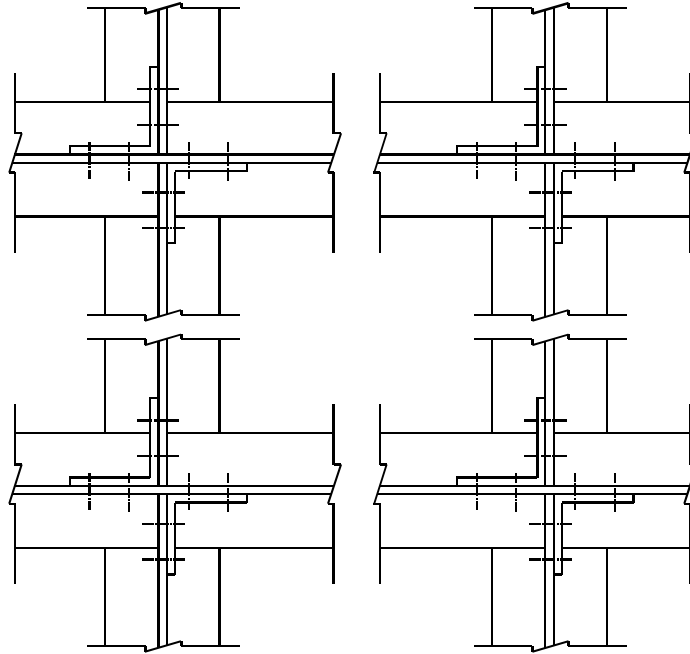

Fig. 11 - Fixing Cross 'T' with cleats

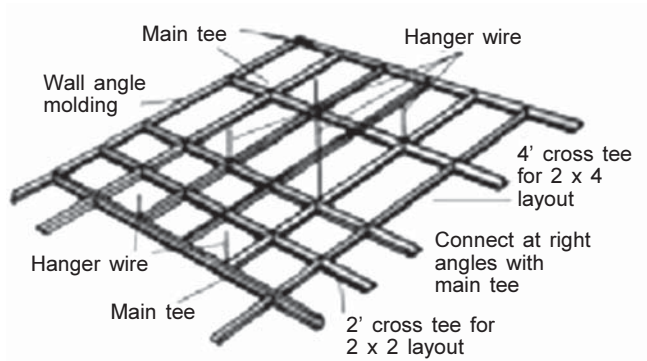

FIG. 12 - The final tee arrangement

Step 6 : Installing ceiling panels:

- The final main and cross 'T' arrangement will look similar to Fig. 12. The top part of the illustration shows an arrangement of a 600x1200 mm layout, while the lower half shows main and cross 'T's arranged for a 600x600 mm layout.

Place the ceiling panels into position by tilting them slightly, lifting them above the framework and letting them fall into place.

LAMINATION

1.0 FIXING LAMINATION ON SURFACES

1.1 General

The wood is a naturally occurring material, can take good polish and gives a good shine and is reasonably water resistant also. However, soft woods and man made boards etc. need some additional coat to give these properties and is achieved by providing additional laminate over the wood surface. There are several makes of laminates available, which are described in Chapter 2. There are certain boards which are pre-laminated but laminates are also available in sheets and can be fixed on the surface.

1.2 Steps involved in lamination:

- Preparing the Surface for Laminate Plastic
- Cutting Laminated Plastic
- Applying Laminated Plastics
- Finishing Off the Job

Step 1: Preparing Surface:

- Laminated plastic sheets of 1.0 mm thickness are recommended for a flat work surface. One can use laminated plastic of 0.8 mm thickness on vertical surfaces.
- Thoroughly sand and clean the surface where plastic laminate is to be applied (Fig. 1). Remove any paint or varnish before applying the laminated plastic.

Regular particle board and plywood make ideal bases for plastic laminates.

Step 2: Cutting Lamination Plastic:

Following points be kept in view for cutting the laminate,

- plastic laminate can be cut with a circular saw, saber saw, backsaw/tenon saw or utility knife. The saw blade should be a fine-tooth blade (Fig. 2). A strip of masking tape placed where the cut line is to be made helps prevent chipping and makes the line easier to see.
- Always cut the sheets of laminated plastic slightly oversized to allow for trimming.
- Special laminate cutting blades are available to use with utility knives (Fig. 3). Use a straightedge or a steel square to guide the knife for a smooth and even cut.

Score the sheet of laminated plastic with the utility knife. Then snap it on the scored line by lifting the shorter end and applying slight pressure (Fig. 4).



FIG. 1 - Sand paper and clean the surface before applying plastic laminate.

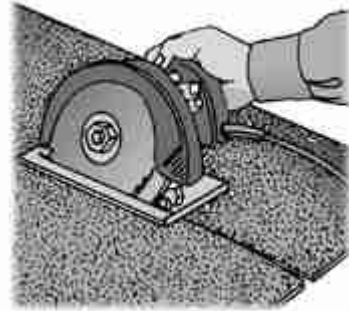

FIG. 2 - We can cut plastic laminate with a regular circular power saw and a fine-tooth blade.



FIG. 3 - Plastic laminate can be cut with a utility knife or using special laminate blades.



FIG. 4 - The laminate will snap after it is scored

Step 3: Applying Laminated Plastic:

- Usually, one can apply laminated plastic sheets with contact cement. Epoxy adhesives can be used, but contact cements are recommended. Fevicol SR and similar other products are available in market.
- Use coarse sandpaper to roughen the surface to be covered. Clean away the sand residue with a light brush or with compressed air.
- After roughening and cleaning, apply adhesive with brush onto the surface (Fig. 5) on which laminate is to be fixed. Also apply a smooth

and even layer of adhesive to the back of the clean laminate sheet. Let both surfaces dry. Check the adhesive manufacturer's advice on the label for the recommended drying time. The general rule is the adhesive should be dry to the touch. A weaker bond will result if you wait too long.

- Use extreme care when laying the sheets. Remember, 50 percent to 75 percent of the bonding strength of adhesive is present in the first contact. Make sure the pieces are accurately positioned before the glued areas touch each other.
- You may need to apply two to three coats of contact adhesive for the trim strips along the counter edges (Fig. 6).
- You can use a regular paintbrush for applying the contact adhesive to both the back of the laminated sheet and the flat surfaces. However, in some cases, a handmade paddle of wood may be better for spreading the cement or adhesive (Fig. 7).
- After the recommended drying period, you are ready to position the sheet of laminate.
- Keep the sheet of laminate and cemented base apart until they are correctly positioned. On narrow strips, lay short lengths of dowel rods about 12" (300mm) apart between the two cemented pieces until they are properly positioned (Fig. 8). The dowel rods can be moved along the surface to keep the cemented pieces apart during positioning.
- When laying a large sheet of laminate, use longer dowel rods (Fig. 9). Keep the 12" (300mm) spacing between the dowel rods. Be sure to use dowels that are at least 1/4"(6mm) in diameter. The larger the better.

When applying laminated sheets to vertical surfaces, you can usually position the glued sheets without using wooden strips or waxed paper (Fig. 10).



FIG. 5 - Brush contact cement over the counter surface after sanding and cleaning it.



FIG. 6 - Apply two or three coats of contact cement on any trim strips along the vertical edges.



FIG. 7 - You can use a handmade wood paddle for spreading the contact cement

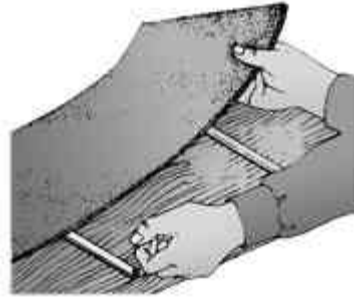

FIG. 8 - Use pieces of dowel rod to position the sheet of plastic laminate.



FIG. 9 - On large areas, longer dowel rods are needed to hold the laminate away from the cemented surface.



FIG. 10 - Sheets applied to vertical areas do not normally require a protective shield of paper.

Step 4 : Finishing

- When the laminate is correctly positioned, remove the dowel rods one at a time as the two pieces are brought together.
- Use a roller to apply pressure to the newly laid sheets of laminated plastic (Fig. 11). Roll the entire surface thoroughly to eliminate air pockets and to be sure the plastic sheet is firmly attached to the surface at all points.
- If one plastic laminate sheet is not large enough to cover the entire surface, one will need to make a joint. To do this, first bond the larger of the two pieces into place.
- Put a narrow strip of wax paper down along the edge of the larger piece (Fig. 12). Use the dowel rods again to keep the second piece of laminate away from the cemented surface. Begin at the joint and position the second piece butting tightly against the first. A strong adhesive tape should be put joining this second piece to the first to

help hold it in place.

- After using the roller to firmly attach the second piece of laminate, go back and carefully lift the edge over the wax paper. Remove the wax paper and reposition the laminate. Finish by using your roller to apply pressure, working from the center of the laminate toward the seam.
- You can also use a wooden block and mallet to assure good adhesion at all points on the newly laid surface. Work from the center of the surface toward the edges to work out any air bubbles that might be hidden underneath.
- When using the same laminate material for edging, apply two coats of cement to the edges and let it dry thoroughly (Fig. 13). Then apply one coat of cement to the back of the laminated sheet.
- Place the edge strip into position carefully, using your fingers to align the sheets along the top edge as they are applied (Fig. 14).
- It is usually best to start applying pressure to the edge strips in the center of each strip (Fig. 15). Work in both directions from the center on long spans. Work short spans from end to end.
- If you need to trim away surplus material or cut portions of the edging strip you can use a fine-tooth backsaw, a router or a file.
- Run your hand along the edge stripping (Fig. 16). It should be slightly wider than the edge it covers. However, the extra width should be at the bottom. It must be perfectly aligned at the top.
- To finish the edges on top, first allow the contact cement to dry according to the manufacturer's directions. If only a small amount of finishing is to be done, one can use a file set at a slight angle. However, most laminate edges today are finished with routers.
- There are special router blades for finishing plastic laminates. The most popular are a flush cut blade and a beveled blade. Beveled blade helps to keep the laminate from chipping along the edge.
- To finish the laminate edges, begin by cleaning the base of your router. Anything stuck to the base or any burrs on the base could scratch your laminate. Putting tape on the base can help take care of this.
- If you are using a bit that requires a guide, set the guide carefully. The bit should cut the edge of the laminate but not the adjoining surface. It is always better to take off a little and make a second pass than to take off too much the first time.

Remove any surplus contact cement with a special solvent. You can use nail polish remover for this purpose.

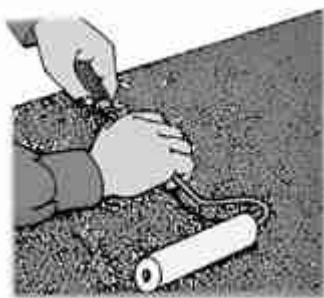

FIG. 11 - Use a roller to apply pressure to the newly laid sheets.

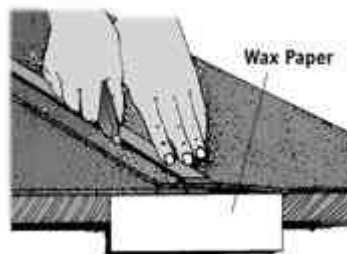

FIG. 12 - Place a strip of waxed paper along the joint area.



FIG. 13 - After applying two coats of cement to edges, apply one coat to back of laminate.



FIG. 14 - Place the edge strip into position carefully.



FIG. 15 - On long spans, apply pressure to edge strips in the center and work to the edges.



FIG. 16 - Edge stripping should be slightly wider than the edge to be covered. The extra width goes at the bottom.