

combined
Service manual



FS-1800/N
FS-3800/N



Page printers

FS-1800/1800N/3800/3800N Series Combined Service Manual

© Kyocera Corporation 2000 All rights reserved. Export Edition

Notice

The information in this manual is subject to change without notification. Additional pages may be inserted in future editions. The reader is asked to excuse any technical inaccuracies or typographical errors in the present edition.

No responsibility is assumed if accidents occur while the service person is following the instructions in this manual.

The contents of this manual are protected by copyright. No part of the manual may be reproduced or copied by any means without the permission of the copyright holder.

Information

This equipment has been tested and found to comply with the limits for a Class A^{*1}/Class B^{*2} digital device, pursuant to Part 15 of the FCC Rules. These limits are designed to provide reasonable protection against

harmful interference in a residential installation. This equipment generates, uses, and can radiate radio frequency energy and, if not installed and used in accordance with the instructions, may cause harmful interference to radio communications. However, there is no guarantee that interference will not occur in a particular installation. If this equipment does cause harmful interference to radio or television reception, which can be determined by turning the equipment off and on, the user is encouraged to try to correct the interference by one or more of the following measures.

Reorient or relocate the receiving antenna.

Increase the separation between the equipment and receiver.

Connect the equipment into an outlet on a circuit different

from that to which the receiver is connected.

Consult the dealer or an experienced radio/TV technician for help.

Changes or modifications not expressly approved by the manufacturer for compliance could void the user's authority to operate the equipment.

*1: FS-1800N/FS-3800N

*2: FS-1800/FS-3800

Important notice to service person

Before attempting service on the equipment, including disassembling, reassembling, troubleshooting, and adjustment, read this manual carefully. During performing service, use extreme care to avoid possible electric shock hazard, burn, and human injuries. Make sure the printer is not provided with any safety facilities other than those primarily intended for the safety of users.

Regarding Tradenames

PRESCRIBE is a registered trademark of Kyocera Corporation.

PRESCRIBE 2e, KPDL, and KIR (Kyocera Image Refinement) are trademarks of Kyocera Corporation.

Diablo 630 is a product of Xerox Corporation.

IBM Proprinter X24E is a product of International Business Machines Corporation.

Epson LQ-850 is a product of Seiko Epson Corporation.

Hewlett-Packard, PCL, and PJJ are registered trademarks of Hewlett-Packard Company.

Centronics is a trade name of Centronics Data Computer Inc.

PostScript is a registered trademark of Adobe Systems Incorporated.

Macintosh is a registered trademark of Apple computer, Inc.

Microsoft, Windows, and Windows NT are registered trademarks of Microsoft Corporation.

PowerPC and Micro-Drive are trademarks of International Business Machines Corporation.

CompactFlash is a trademark of SanDisk Corporation.

ENERGY STAR is a U.S. registered mark.

All other brand and product names are registered trademarks or trademarks of their respective companies.

This Kyocera page printer uses PeerlessPrintXL to provide the HP LaserJet compatible PCL6 language emulation.

PeerlessPrintXL is a trademark of The Peerless Group, Redondo Beach, CA 90278, U.S.A.

This product was developed using the Tornado™ Real Time Operating System and Tools from Wind River Systems.

Contains UFST™ and MicroType® from Agfa Corporation.

Fine 1200 mode uses iRET image enhancement technology.

iRET is a trademark of Oak Technology, Inc.

Conventions

Throughout this manual, the following conventions are used:

Italic letters refer related chapters or sections or documentations.



This symbol followed by **WARNING** denotes that the following paragraph(s) includes precautions which, if ignored, could result in personal injury, and/or irrevocable damage to the printer.

When followed by **CAUTION** this symbol denotes that the following paragraph(s) include the precautions which, if ignored, could result in damage to the printer.

About the chapters

Unless otherwise specified, the content of this manual apply to both printer models of Ecosys FS-1800, FS-1800N, FS-3800 and FS-3800N.

The manual is comprised of the following chapters:

- Chapter 1: Product Information
- Chapter 2: Installation/Operation
- Chapter 3: Maintenance/Adjustments
- Chapter 4: Operation Overview
- Chapter 5: Disassembly
- Chapter 6: Troubleshooting
- Appendix A: Diagrams
- Appendix B: Status Page
- Appendix C: Interface

REVISION HISTORY

Version	Date	Replaced Pages	Remarks
1.00A	23-Oct-2000	-	
1.10	4-Dec-2000	1-7, 3-12, 3-14, 3-15, 3-16, 4-37, 5-12, 5-37, 6-11,6-15, 6-16, 6-17, 6-18, 6-19, 6-20, 6-21, 6-22,6-23, 6-24, B-4, B-5	
1.20	4-Jul-2001	1-6, 1-7, 2-18, 2-20, 3-14, 3-15, 3-16, 3-19, 3-20	

TO OBTAIN THE LATEST PRINTER DRIVERS AND UTILITIES, VISIT US AT OUR INTERNET HOME PAGE: <http://www.kyocera.com/w2k>



© 2001 Kyocera Corporation
This document is a preliminary draft and is subject to change without notice.
The information contained herein is confidential.
All rights reserved. No part of this document may be reproduced or transmitted in any form or by any means electronic or mechanical, including photocopying and recording, or by any information storage or retrieval system, without permission in writing from Kyocera Corporation.

Chapter 1 **Product Information**

Chapter 1 Contents

1-1 Printer specifications	1-3
1-1-1 Specifications	1-3
(1) Engine	1-3
(2) Controller	1-4
(3) Weight and dimensions	1-4
(4) Power requirements	1-5
(5) Environmental requirements	1-5
1-1-2 Available option memory/device	1-6
(1) Expansion memory (DIMM)	1-6
(2) Memory card (CompactFlash)	1-7
(3) Hard disk (Microdrive)	1-8
1-2 Names of parts	1-9
1-2-1 Names of parts	1-9
1-3 Safety information	1-10
1-3-1 Safety information	1-10
(1) Laser safety	1-10
(2) Laser notice	1-10
(3) Laser caution label on the scanner unit	1-10
(4) CDRH regulations (U.S.A.)	1-12
(5) Ozone concentration	1-12
(6) FCC statement (U.S.A.)	1-12
a) For the FS-1800 and FS-3800 models	1-12
b) For the FS-1800N and FS-3800N models	1-13
(7) Canadian Department of Communications compliance statement	1-13
(8) Avis de conformité aux normes du ministère des Communications du Canada	1-13
(9) ISO 7779	1-13
(10) CE marking directive	1-14
(11) Declaration of conformity (Australia)	1-14
1-4 Environmental requirements	1-15
1-4-1 Environmental conditions	1-15
(1) Clearance	1-16
(2) Places to avoid	1-17
(3) Note on power	1-17
(4) Removing the printer	1-18
1-5 About the toner container	1-19
1-5-1 Toner container	1-19
(1) Toner container handling	1-19
(2) Toner container storage	1-20

1-1 Printer specifications

1-1-1 Specifications

(1) Engine

Item	FS-1800/1800N	FS-3800/3800N
Print method	Electrophotography laser scan	←
Print speed (when printing multiple page)	16 pages/min. (A4) 17 pages/min. (Letter)	24 pages/min. (A4) 25 pages/min. (Letter)
Resolution	Fine 1200 mode Fast 1200 mode with KIR 600 dpi with KIR 300 dpi with KIR	←
Smoothing	KIR (Kyocera Image Refinement)	←
First print (A4 or letter, 23 °C), depends on input data	Approximately 17.5 seconds or less	Approximately 9 seconds or less
Warm-up time (23 °C)	Standby: 20 seconds or less	35 seconds or less
	Sleeping: 6.5 seconds or less	35 seconds or less
Maximum duty cycle (A4)	65,000 pages/month	100,000 pages/month
Machine life expectancy	300,000 pages of printing or 5 years (expandable to 900,000 pages of printing using MK kits)	←
Development	Mono component dry developer	←
Laser	Visible laser	←
Main charger	Scorotron plus charging	←
Transferring	Negative charger roller	←
Separation	Curvature separation	←
Drum cleaning	Blade	←
Drum discharging	Eraser lamp (LED array)	←
Fuser	Heat roller and press roller	←
Paper	Plain paper	←
Capacity of paper feed source (80 g/m ² [0.11 mm thickness])	Cassette: 500 sheets, MP tray: 100 sheets	←
Capacity of output trays (80 g/m ² [0.11 mm thickness])	Face-up: 250 sheets, Face-down: 250 sheets	←

(2) Controller

Item		FS-1800/1800N	FS-3800/3800N
CPU		PowerPC405GF/200MHz	PowerPC740/200MHz
System ROM		4 MB Mask (or Flash) DIMM	←
Font ROM		2 MB	←
Main (Video) RAM		FS-1800 model: 8 MB FS-1800N model: 24 MB	FS-3800 model: 16 MB FS-3800N model: 32 MB
Maximum:		264 MB (Including main RAM)	272 MB (Including main RAM)
Slot:		2 DIMM slots (A 16 MB DIMM is factory-installed in one slot for FS-1800N.)	2 DIMM slots (A 16 MB DIMM is factory-installed in one slot for FS-3800N.)
DIMM size:		16, 32, 64, 128 MB	←
Memory card (Optional)		CompactFlash	←
Hard disk (Optional)		Microdrive (340 MB)	←
Host interface	Parallel:	High-speed, bidirectional (IEEE1284)	←
	Serial:	RS-232C, Maximum speed: 115.2 Kbps	←
Network interface card: (KUIO-LV [3.3 V])		10/100 Base-TX, type IB-21 (Standard with equipped FS-1800N)	10/100 Base-TX, type IB-21 (Standard with equipped FS-3800N)
Page description language		Prescribe	←
Standard emulation modes		PCL6, Diablo 630, IBM proprinter X24E, Epson LQ850, Line printer, KPDL	←

(3) Weight and dimensions

Item		FS-1800/1800N	FS-3800/3800N
Main unit (excluding protrusions)	Width:	34.5 cm (13-9/16 inches)	←
	Height:	30.0 cm (11-13/16 inches)	←
	Depth:	39.0 cm (15-3/8 inches)	←
	Weight:	13 Kg (28-5/8 lb.)	←

(4) Power requirements

Item		FS-1800/1800N	FS-3800/3800N
Voltage/current	US/Canada:	120 V AC $\pm 10\%$, 60 Hz $\pm 2\%$ / 7.2 A	←
	Europe/Asia:	220 - 240 V AC $\pm 10\%$, 50/60 Hz $\pm 2\%$ / 3.6 A	←
Watts	Average:	FS-1800 model: 328 W	FS-3800 model: 499 W
		FS-1800N model: 961 W	FS-3800N model: 972 W
	Maximum:	120 V AC model: 961 W	120 V AC model: 972 W
		220 - 240 V AC model: 961 W	220 - 240 V AC model: 972 W
	Standby (Ready):	FS-1800 model: 21 W	FS-3800 model: 126 W
		FS-1800N model: 23 W	FS-3800N model: 126 W
Sleeping:	FS-1800 model: 14 W	FS-3800 model: 14 W	
	FS-1800N model: 15 W	FS-3800N model: 16 W	

(5) Environmental requirements

Item	FS-1800/1800N	FS-3800/3800N
Operating temperature and humidity	10 to 32.5 °C (50 to 90.5 °F), 20 to 80 %RH	←
Maximum altitude	2,000 m (6,500 feet)	←
Noise emission (Excluding peaks, measured at 1 m from printer, as per ISO7779)	Maximum: 53 dB(A) , Standby: 35 dB(A)	Maximum: 57 dB(A) , Standby: 39 dB(A)

1-1-2 Available option memory/device

(1) Expansion memory (DIMM)

The following memory DIMMs are available for use with the printer. For more information about DIMM, refer to Section 2-2-4 *Expanding the memory (DIMM)* on page 2-11.

NOTE Availability of the memory DIMMs, manufacturers, and specifications may change without notice. No responsibility is assumed by Kyocera Mita with respect to loss or damage caused by the use of these DIMMs.

Manufacturer	Capacity	Model
Melco Inc.	16 MB	PM-HP-16M-KC
	32 MB	PM-HP-32M-KC
	64 MB	PM-HP-64M-KC
	128 MB	PM-HP-128M-KC

This page is intentionally blank.

(2) Memory card (CompactFlash)

The following memory cards are available for use with the printer. Do not insert or remove a memory card (CompactFlash) while power is on. If the memory card is removed while the printer is on, damage could result in the printer's electronics or the memory card. Refer to Section *Installing the option memory card (CompactFlash)* on page 2-16.

NOTE Availability of the following memory cards (CompactFlash), manufacturers, and specifications may change without notice. No responsibility is assumed by kyocera Mita with respect to loss or damage caused by the use of these memory card.

Manufacturer	Capacity	Model
SanDisk	8 MB	SDCFBS-8-101
	16 MB	SDCFBS-16-101
	24 MB	SDCFBS-24-101
	32 MB	SDCFBS-32-101
	48 MB	SDCFBS-48-101
	64 MB	SDCFBS-64-101
	96 MB	SDCFBS-96-101
Viking	4 MB	CF4M
	8 MB	CF8M
	12 MB	CF12M
	16 MB	CF16M
	24 MB	CF24M
	32 MB	CF32M
	48 MB	CF48M
	64 MB	CF64M
	80 MB	CF80M
Kingston	8 MB	CF/8
	16 MB	CF/16
	24 MB	CF/24
	32 MB	CF/32
	48 MB	CF/48
	64 MB	CF/64
	96 MB	CF/96

Manufacturer	Capacity	Model
DelkinDevices Inc.	8 MB	DDCFFLS2-008
	16 MB	DDCFFLS2-016
	24 MB	DDCFFLS2-024
	32 MB	DDCFFLS2-032
	48 MB	DDCFFLS2-048
	64 MB	DDCFFLS2-064
	96 MB	DDCFFLS2-096
HITACHI	8 MB	HB286008C4
	16 MB	HB286016C4
	32 MB	HB289032C4
	48 MB	HB289048C4
	64 MB	HB288064C5
Transcend	4 MB	TS4MFLASHCP
	8 MB	TS8MFLASHCP
	16 MB	TS16MFLASHCP
	32 MB	TS32MFLASHCP
SST	8 MB	SST48CF008
	16 MB	SST48CF016
	24 MB	SST48CF024
	32 MB	SST48CF032
	48 MB	SST48CF048
	64 MB	SST48CF064
	96 MB	SST48CF096
LEXAR Media	16 MB	-
	32 MB	-
	48 MB	-
	64 MB	-
	80 MB	-

(3) Hard disk (Microdrive)

The following hard disk is available for the printer:

IBM Microdrive 340 MB capacity type

1-2 Names of parts

1-2-1 Names of parts

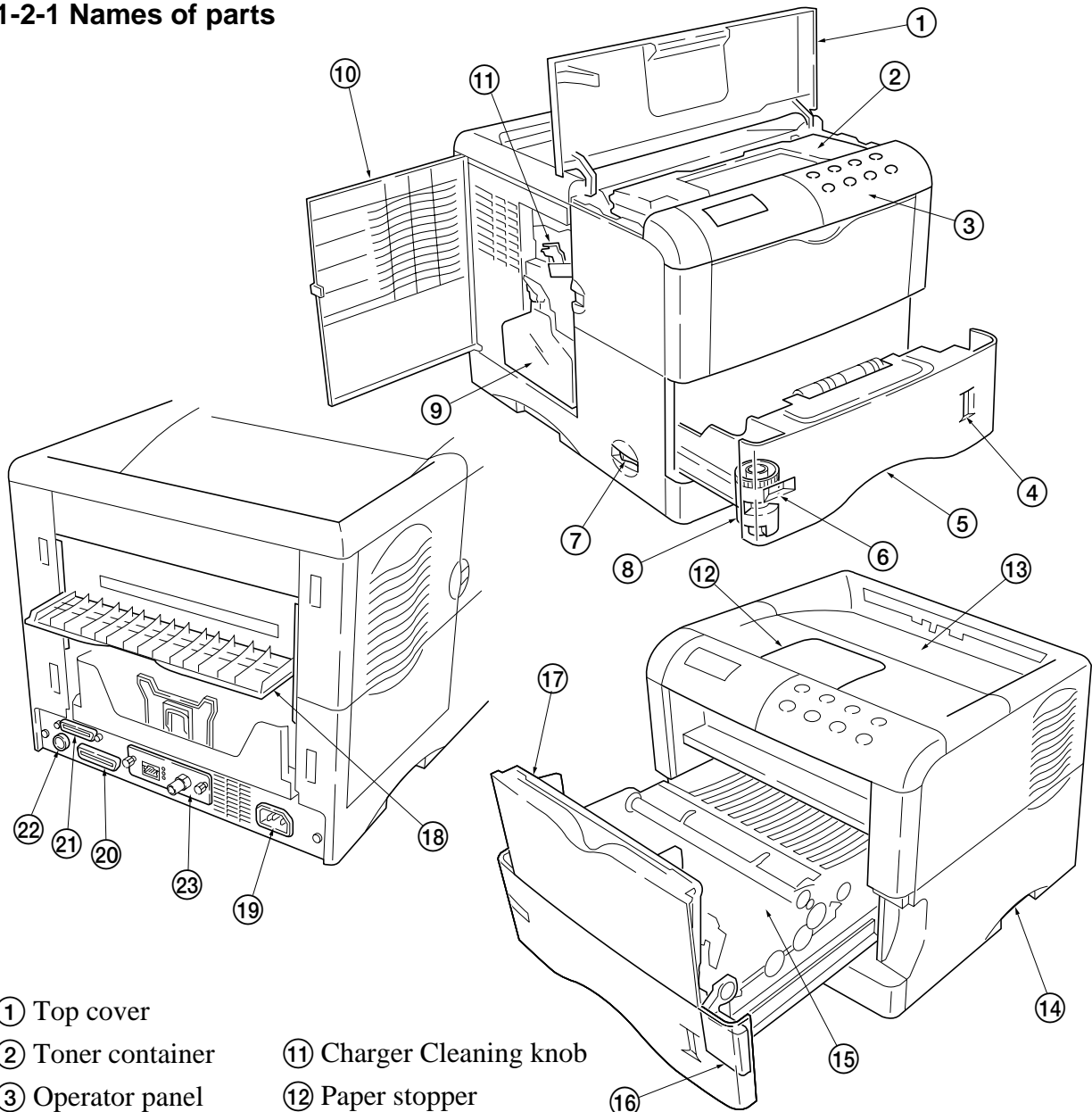

- ① Top cover
 - ② Toner container
 - ③ Operator panel
 - ④ Paper gauge
 - ⑤ Paper cassette
 - ⑥ Paper size window
 - ⑦ Power switch
 - ⑧ Paper size dial
 - ⑨ Waste toner bottle
 - ⑩ Side cover
 - ⑪ Charger Cleaning knob
 - ⑫ Paper stopper
 - ⑬ Face-down output tray
 - ⑭ Memory card slot
 - ⑮ Paper feed unit
 - ⑯ Paper feed unit release lever
 - ⑰ MP tray
 - ⑱ Rear cover
 - ⑲ AC inlet
 - ⑳ Parallel interface connector
 - ㉑ Serial interface connector
 - ㉒ Option unit connector
 - ㉓ Network interface card *1
- *1: Standard-installed with the FS-1800N/3800N models (Normally covered with a cover plate)

Figure 1-2-1 Name of parts

1-3 Safety information

1-3-1 Safety information

(1) Laser safety

This printer is certified as a Class 1 laser product under the U.S. Department of Health and Human Services (DHHS) Radiation Performance Standard according to Radiation Control for Health and Safety Act of 1968. This means that the printer does not produce hazardous laser radiation. Since radiation emitted inside the printer is completely confined within protective housings and external covers, the laser beam cannot escape from the printer during any phase of user operation.

(2) Laser notice

This printer is certified in the U.S. to conform to the requirements of DHHS 21 CFR Subchapter for Class I (1) laser products, and elsewhere is certified as a Class I laser product conforming to the requirements of IEC 825.

(3) Laser caution label on the scanner unit

The laser scanner unit inside the printer has the following label affixed on its top. Observe the laser radiation warning and figures when handling the laser scanner unit.

WARNING



Use of controls or adjustments or performance of procedures other than those specified herein may result in hazardous radiation exposure.

Laser radiation warning

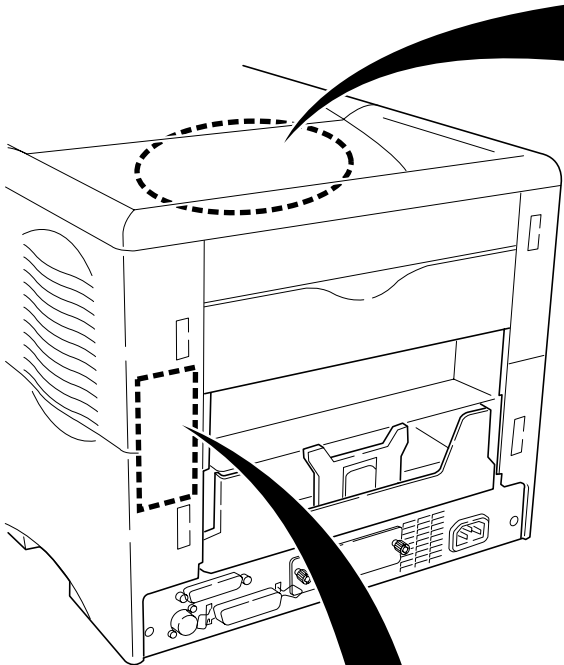

DANGER	· LASER RADIATION WHEN OPEN. · AVOID DIRECT EXPOSURE TO BEAM.
ATTENTION	· RAYONNEMENT LASER EN CAS D'OUVERTURE. · EXPOSITION DANGEREUSE AU FAISCEAU.
VORSICHT	· LASERSTRAHLUNG, WENN ABDECKUNG GEÖFFNET. · NICHT DEM STRAHL AUSSETZEN.
ATTENZIONE	· RADIAZIONE LASER IN CASO DI APERTURA. · EVITARE L'ESPOSIZIONE AL FASCIO.
PRECAUCION	· RADIACIONE LASER CUANDO SE ABRE. · EVITAR EXPONERSE AL RAYO.
VARO!	· AVATTAESSA OLET ALTTIINA LASERSÄTEILYLLE. · ÄLÄ KATSO SÄTEESEEN.

警告 · このカバーの内部ではレーザー光が放射されています。レーザー光にさらされないようにしてください。

警告 · 开盖时, 可能有激光外溢! 应避免激光直接照射。

警告 · 内部雷射放射中, 請勿隨意打開蓋子。

This label is affixed atop of the laser scanner unit inside the printer.

FS-3800 US/Canada model

FS-3800 120V ~ 60Hz 7.2A
KYOCERA CORPORATION
 MIE PLANT TAMAKI BLOCK
 704-19 NOJINO, TAMAKI-TOWN
 WATARAI-COUNTY, MIE-PREF. JAPAN
 MANUFACTURED:

THIS LASER PRODUCT CONFORMS TO THE APPLICABLE REQUIREMENTS OF FEDERAL REGULATIONS 21 CFR CHAPTER 1, SUBCHAPTER J.

Tested To Comply With FCC Standards
 FOR HOME OR OFFICE USE

8J66 UL 1950
US LISTED

This device complies with Part 15 of the FCC Rules. Operation is subject to the following two conditions: (1) This device may not cause harmful interference, and (2) this device must accept any interference received, including interference that may cause undesired operation.

This Class B digital apparatus complies with Canadian ICES-003.
 Cet appareil numérique de la classe B est conforme à la norme NMB-003 du Canada.

CAUTION
 REMOVE POWER CORD BEFORE SERVICE AND FUSE REPLACEMENT.

ATTENTION
 POUR PRÉVENIR LES CHOCS ÉLECTRIQUES, COUPER L'ALIMENTATION AVANT DE REMPLACER LE FUSIBLE.

PRECAUZIONE
 PRIMA DI CAMBIARE I FIESIBILI O DI ESEGUIRE RIPARAZIONI, STACCATTE IL CADO DI ALIMENTAZIONE.
 YM MADE IN JAPAN

FS-3800 Asian countries model

FS-3800 220-240V ~ 60Hz 3.6A
KYOCERA CORPORATION
 MADE IN JAPAN

CLASS 1 LASER PRODUCT TO IEC825
 LASER KLASSE 1 NACH IEC825
 KLASSE 1 LASER PRODUKT I. H. T. IEC825
 LUOKAN 1 LASERLAITE

CAUTION
 REMOVE POWER CORD BEFORE SERVICE AND FUSE REPLACEMENT.

VORSICHT
 VOR WARTUNG UND SICHERUNGS-WECHSEL NETZSTECKER ZIEHEN.

ATTENTION
 POUR PRÉVENIR LES CHOCS ÉLECTRIQUES, COUPER L'ALIMENTATION AVANT DE REMPLACER LE FUSIBLE.

ATENCION
 DESENCHUFE EL CORDÓN DE ALIMENTACIÓN ANTES DEL SERVICIO Y DEL REEMPLAZO DEL FUSIBLE.

PRECAUZIONE
 PRIMA DI CAMBIARE I FIESIBILI O DI ESEGUIRE RIPARAZIONI, STACCATTE IL CADO DI ALIMENTAZIONE.

FS-3800 Europe/Pacific model

FS-3800 220-240V ~ 50Hz 3.6A
KYOCERA CORPORATION
 MADE IN JAPAN

CLASS 1 LASER PRODUCT TO IEC825
 LASER KLASSE 1 NACH IEC825
 KLASSE 1 LASER PRODUKT I. H. T. IEC825
 LUOKAN 1 LASERLAITE

CAUTION ACN003852444
 REMOVE POWER CORD BEFORE SERVICE AND FUSE REPLACEMENT.

VORSICHT
 VOR WARTUNG UND SICHERUNGS-WECHSEL NETZSTECKER ZIEHEN.

ATTENTION
 POUR PRÉVENIR LES CHOCS ÉLECTRIQUES, COUPER L'ALIMENTATION AVANT DE REMPLACER LE FUSIBLE.

ATENCION
 DESENCHUFE EL CORDÓN DE ALIMENTACIÓN ANTES DEL SERVICIO Y DEL REEMPLAZO DEL FUSIBLE.

PRECAUZIONE
 PRIMA DI CAMBIARE I FIESIBILI O DI ESEGUIRE RIPARAZIONI, STACCATTE IL CADO DI ALIMENTAZIONE.

Figure 1-3-1 Caution labels

(4) CDRH regulations (U.S.A.)

The Center of Devices and Radiological Health (CDRH) of the U.S. Food and Drug Administration implemented regulations for laser products on August 2, 1976. These regulations apply to laser products manufactured after August 1, 1976. Compliance is mandatory for products marketed in the United States. A label indicating compliance with the CDRH regulations must be attached to laser products marketed in the United States.

(5) Ozone concentration

The printers generate ozone gas (O³) which may concentrate in the place of installation and cause an unpleasant smell. To minimize concentration of ozone gas to less than 0.1 ppm, we recommend you not to install the printer in a confined area where ventilation is blocked.

(6) FCC statement (U.S.A.)

a) For the FS-1800 and FS-3800 models

This device complies with Part 15 of the FCC Rules. Operation is subject to the following two conditions: (1) This device may not cause harmful interference, and (2) this device must accept any interference received, including interference that may cause undesired operation.

This equipment has been tested and found to comply with the limits for Class B digital device, pursuant to Part 15 of the FCC Rules. These limits are designed to provide reasonable protection against harmful interference in a residential installation. This equipment generates, uses, and can radiate radio frequency energy and, if not installed and used in accordance with the instructions, may cause harmful interference to radio communications. However, there is no guarantee that interference will not occur in a particular installation. If this equipment does cause harmful interferences to radio or television reception, which can be determined by turning the equipment off and on, the user is encouraged to try to correct the interference by one or more of the following measures:

- Reorient or relocate the receiving antenna.
- Increase the separation between the equipment and receiver.
- Connect the equipment into an outlet on a circuit different from that to which the receiver is connected.
- Consult the dealer or an experienced radio/TV technician for help.

Changes or modifications not expressly approved by the manufacturer for compliance could void the user's authority to operate the equipment. Shielded circular cable should be used for interfacing with the computer.

Any modification without prior permission may cause harmful interference.

If any modification/change is introduced to this equipment without prior permission, Kyocera as the manufacturer cannot guarantee compliance with FCC rules. To use equipment which does not comply with FCC rules is prohibited. The printer may be optionally installed with the following units:

Options conforming to the Class B limit

- Sorter SO-60
- Duplexer DU-60
- Paper feeder PF-60

b) For the FS-1800N and FS-3800N models

This equipment has been tested and found to comply with the limits for Class A digital device, pursuant to Part 15 of the FCC Rules. These limits are designed to provide reasonable protection against harmful interference when the equipment is operated in a commercial environment. This equipment generates, uses, and can radiate radio frequency energy and, if not installed and used in accordance with the instruction manual, may cause harmful interference to radio communications. Operation of this equipment in a residential area is likely to cause harmful interference in which case the user will be required to correct the interference at his own expense.

WARNING



FCC Regulations state that any unauthorized changes or modifications to this equipment not expressly approved by the manufacturer could void the user's authority to operate the equipment.

(7) Canadian Department of Communications compliance statement

This Class B digital apparatus complies with Canadian ICES-003.

(8) Avis de conformité aux normes du ministère des Communications du Canada

Cet appareil numérique de la classe B est conforme à la norme NMB-003 du Canada.

(9) ISO 7779

Maschinenlärminformationsverordnung 3. GSGV, 18.01.1991: Der höchste Schalldruckpegel beträgt 70 dB(A) oder weniger gemäß ISO 7779.

(10) CE marking directive

According to Council Directive 89/336/EEC and 73/23/EEC

declares that the product

Product name: Page printer

Model name: FS-1800/FS-3800/FS-1800N/FS-3800N (as tested with the enhancement optional unit: PF-60, DU-60 and SO-60)

Conforms to the following product specifications.

EN 55 022:1998 Class B

EN 61 000-3-2:1995

EN 61 000-3-3:1995

EN 55 024:1998

EN 60 950:1992 (+A1+A2+A3+A4+A11)

EN 60 825-1:1994+A11

(11) Declaration of conformity (Australia)

declares that the product

Product number: Page printer

Model name: FS-1800/FS-3800/FS-1800N/FS-3800N (as tested with the enhancement optional units: PF-60, DU-60 and SO-60)

Description of device: This page printer model FS-3800 is the 24 ppm (FS-1800 is the 16 ppm); A4 size and utilizes plain paper; laser; dry toner, etc. The printer can be equipped with several enhancement optional units such as a paper feeder PF-60, a duplexer DU-60, a sorter SO-60, etc.

The printer conforms to the following product specifications:

AS/NZS 3548; 1995 (EN 55 022:1994 Class B)

IEC60950 (EN 60 950:1992+A1+A2+A3+A4+A11)

IEC60825-1 (EN 60 825-1:1994+A11)

1-4 Environmental requirements

1-4-1 Environmental conditions

The *Environmental requirements* section on page 1-5 should be observed to ensure the optimum operation of the printer. The use of the printer in a location which does not satisfy the requirements may result in troubles and risk shortening its service life.

The printer will work best if it is installed in a location that is:

- Level and well supported (Place the printer on a table or desk.)
- Not exposed to sunlight or other bright light (not next to an uncurtained window). Do not place the printer on an unstable cart, stand or table.
- Near an AC wall outlet, preferably one that can be used for the printer alone. The outlet should have a ground slot, or an adapter should be used. If you use an extension cord, the total length of the power cord plus extension cord should be 17 feet or 5 meters or less.
- Well ventilated, not too hot or cold, and not too damp or dry (See section *Environmental requirements* on page 1-5). If you install the printer where the temperature or humidity is outside the requirements in section Environmental requirements in chapter 1, the best print quality may not be expected and there will be an increased chance of paper jams.
- Provide a sufficient clearances around the printer to ensure ventilation and ease of access. (See section *Clearance* on next page).

(1) Clearance

Allow the necessary minimum clearance on all sides of the printer as below.

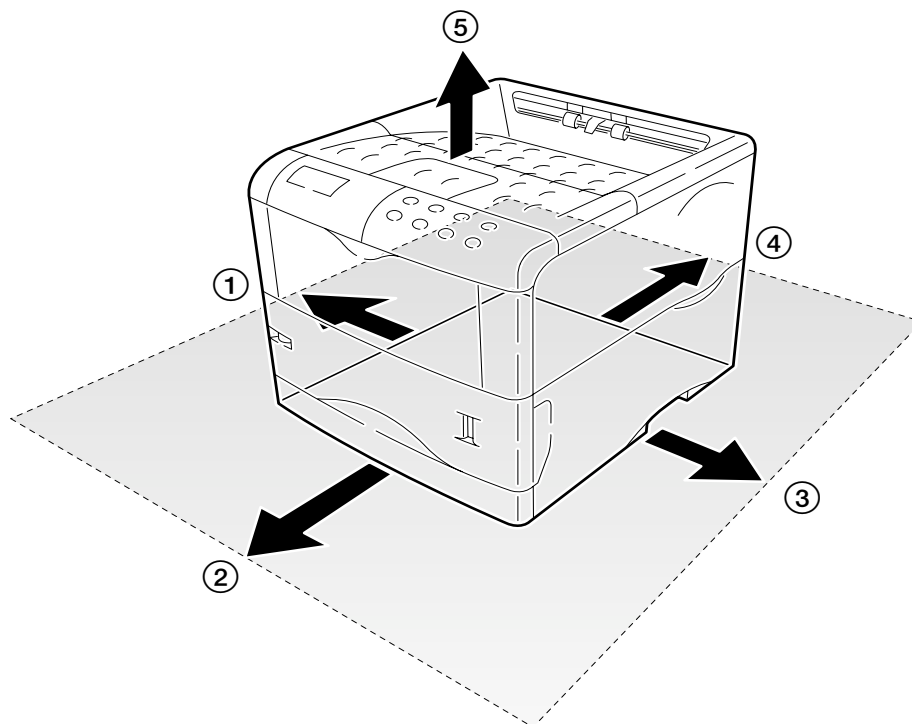

Figure 1-4-1 Clearances

Ref.	Clearance	Dimensions [Minimum]
①	Left	30 cm (11-13/16 inches)
②	Front	60 cm (23-5/8 inches)
③	Right	25 cm (9-7/8 inches)
④	Back	20 cm (7-7/8 inches)
⑤	Head room	30 cm (11-13/16 inches)

(2) Places to avoid

Avoid installing the printer in locations exposed to:

- Direct drafts of hot or cold air.
- Direct drafts of outside air. (Avoid locations next to outside doors.)
- Sudden temperature or humidity changes.
- Any source of high heat, such as a radiator or stove.
- Excessive dust. Dust and smoke may cause contamination on the laser scanner window, causing print quality problem.
- Vibration.
- Ammonia fumes or other harmful fumes. (In case of fumigating the room or saturate it with insecticide, remove the printer first.)
- Avoid greenhouse-like rooms. (Because of sunlight and humidity.)
- Avoid enclosed spaces that block ventilation.
- Avoid sites more than 6,500 feet or 2,000 meters above sea level.

(3) Note on power

Use only the power source voltage conforming to the printer's rated power voltage. Do not use other power sources.

- Disconnect the printer from the power source before attempting removal or replacement of an electrical component or a printed-circuit board.
- The printer should not be connected to a power source until the instruction is given to do so when performing tests described in this manual.
- In connecting the printer power, exercise an extreme care in handling the power supply or any other electric parts which may give an electric shock.
- Before performing maintenance or repair, power from both the power source and the associated peripheral devices (computer, sorter, etc.) should be disconnected, unless otherwise specified.
- To avoid possible electrical shock, extreme caution must be exercised in handling the power cord and any other electrical part.
- An easily accessible socket outlet must be provided near the equipment.

WARNING



As the disconnect device is not incorporated in the printer's AC primary circuit, an easily accessible socket outlet must be provided near the equipment.

(4) Removing the printer

Observe the following precautions in removal and transportation of the printer.

- Be sure to repack the printer in its original carton.
- Do not leave the printer, toner container, process unit and other printer modules inside a vehicle if the outdoor temperature is more than 25 °C. As unexpectedly high temperature may develop inside when a vehicle is parked for a long period of time, the drum, toner container, process unit and the supplies should be removed from the vehicle. The vehicle during transportation should be parked in the shade or with the window open to allow minimum air circulation or the adequate air conditioning should be made.
- Should the printer be left in a vehicle, it may not be exposed to the temperature change of more than 7 °C within 30 minutes.
- Before removing the printer to a warm place, wrap it in a blanket, etc., before crating it. Allow approximately two to three hours after having moved after uncrated. Failure to observe the above may result in moisture condensation which will affect the performance of the printer.

1-5 About the toner container

1-5-1 Toner container

The printer should use a Kyocera TK-60/TK-60E toner kit. To ensure the high print quality and long service life, the following handling precautions should apply:

CAUTION



As the Ecosys printers are designed to ensure the optimum print quality when used with Kyocera's proprietary toner, Kyocera do not recommend to use any refilled toner containers that may be available commercially. This is because Kyocera have no means of control over how such refilled toner could affect the print quality and the reliability of the printer.

(1) Toner container handling

To loosen and mix the toner inside before use, with the label side down, thoroughly shake the toner container ① (in the direction of the arrows) ten times or more.

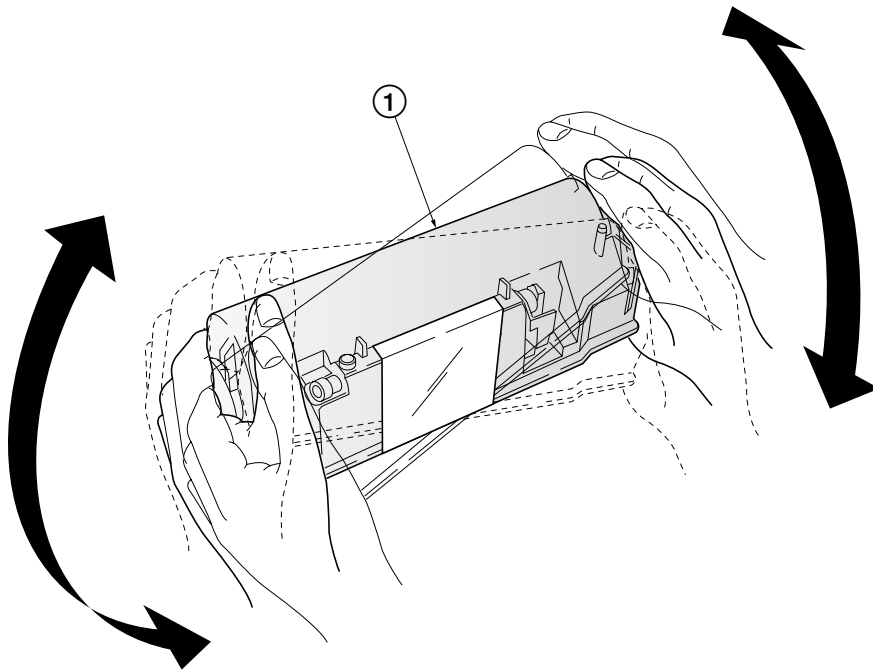

Figure 1-5-1 Toner container handling

CAUTION



The toner container is not designed for disassembly or refilling. Do not attempt to disassemble or refill the toner container.

(2) Toner container storage

The toner contained in the container is susceptible to temperature and humidity. To ensure the high print quality, store the toner container in a place that satisfies the following environmental conditions:

Temperature: -20 to 40 °C (-4 to 104 °F)

Humidity: 15 to 90 % RH

NOTE

If the toner container is removed from the printer's developer, put it in a protective bag and keep it in a dark place.

CAUTION



If the printer is shipped for return, etc., do not ship it with the toner container installed. Remove the toner container from the developer and put in a plastic bag and seal the plastic bag. Otherwise, toner may leak and contamination may result in the printer.

Chapter 2 Installation/Operation

Chapter 2 Contents

2-1 Unpacking	2-3
2-1-1 Unpacking and inspection	2-3
2-2 Installing the printer	2-5
2-2-1 Installing the toner container	2-5
Removing the toner container	2-7
2-2-2 Installing the waste toner bottle	2-8
Removing the waste toner bottle	2-9
2-2-3 Developer initialization (automatic)	2-10
2-2-4 Expanding the memory (DIMM)	2-11
(1) Minimum memory requirements	2-11
(2) DIMM specifications	2-11
(3) Notes on handling DIMM	2-12
(4) Installing the DIMM	2-13
(5) Testing the expansion memory	2-14
(6) Installing the option hard disk (Microdrive)	2-15
(7) Installing the option memory card (CompactFlash)	2-16
(8) Installing the option network interface card	2-17
2-3 Using the operator panel	2-18
2-3-1 Operator panel	2-18
(1) Indicators and keys	2-18
(2) Interface indicator	2-20
(3) Paper size indicator	2-20
(4) Paper type Indicator	2-21
(5) Message display	2-22
2-3-2 Menu selection system	2-23
(1) Menu selection and sequence	2-23

2-1 Unpacking

2-1-1 Unpacking and inspection

The printer package should contain the items as shown in the figure below. After unpacking, remove the printer and all the accessories from the package.

For unpacking, place the box containing the printer on a flat, stable surface. Remove the manuals, toner kit, and other items located on top of the spacer. Then remove the spacer. Carefully remove the printer. Obtain help from other persons if necessary.

For the FS-1800N/3800N, the CD-ROM (Network library) and the manual for the network interface card are shipped together with the components listed below.

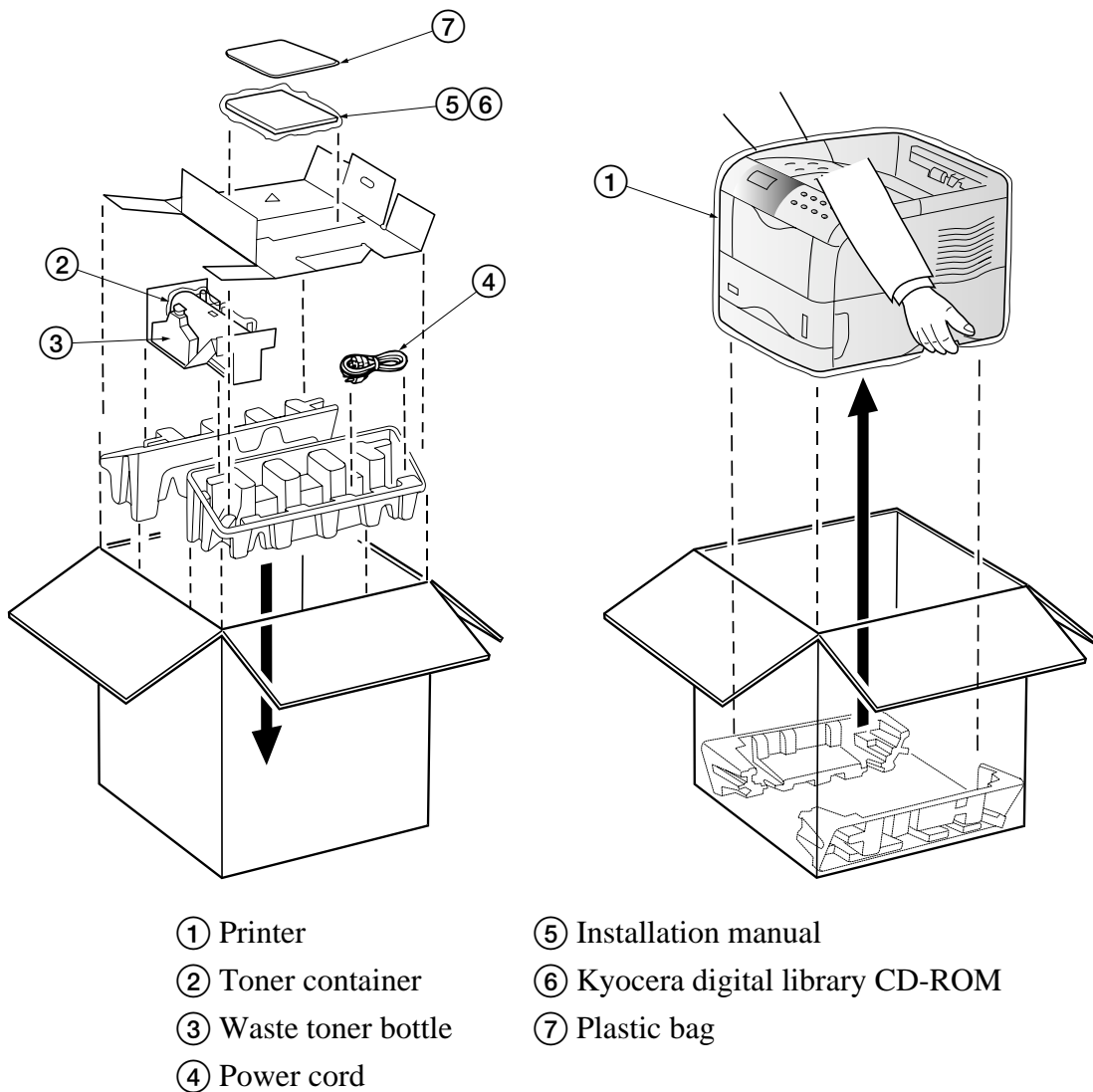
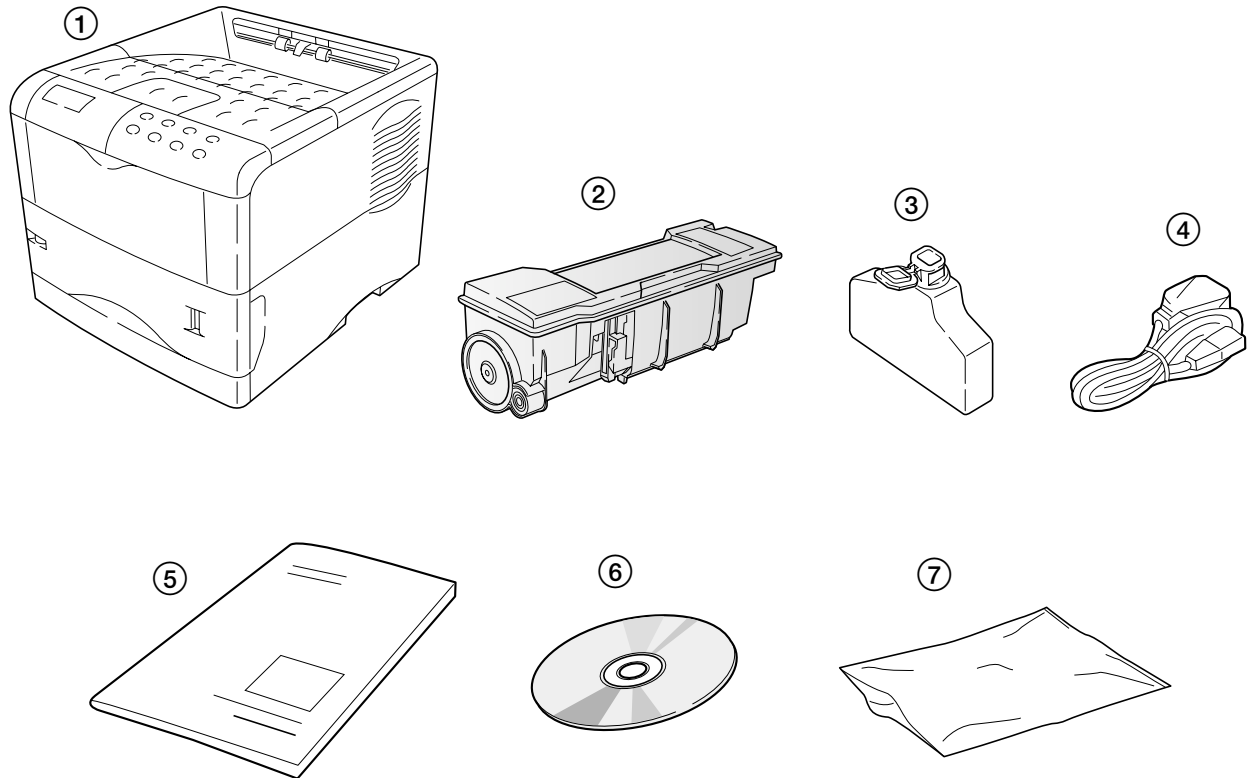

Figure 2-1-1 Unpacking



- ① Printer
- ② Toner container
- ③ Waste toner bottle
- ④ Power cord
- ⑤ Installation manual
- ⑥ Kyocera digital library CD-ROM
- ⑦ Plastic bag

Figure 2-1-2 List of shipped components

2-2 Installing the printer

Installing the printer requires several steps. Proceed as follows in sequence.

2-2-1 Installing the toner container

1. Open the top cover all the way.
2. Take toner container ① from the bag. With the label side down and pivoting on the middle of the container, thoroughly shake the toner container (in the direction of the arrows) ten times or more to loosen and mix the toner inside.

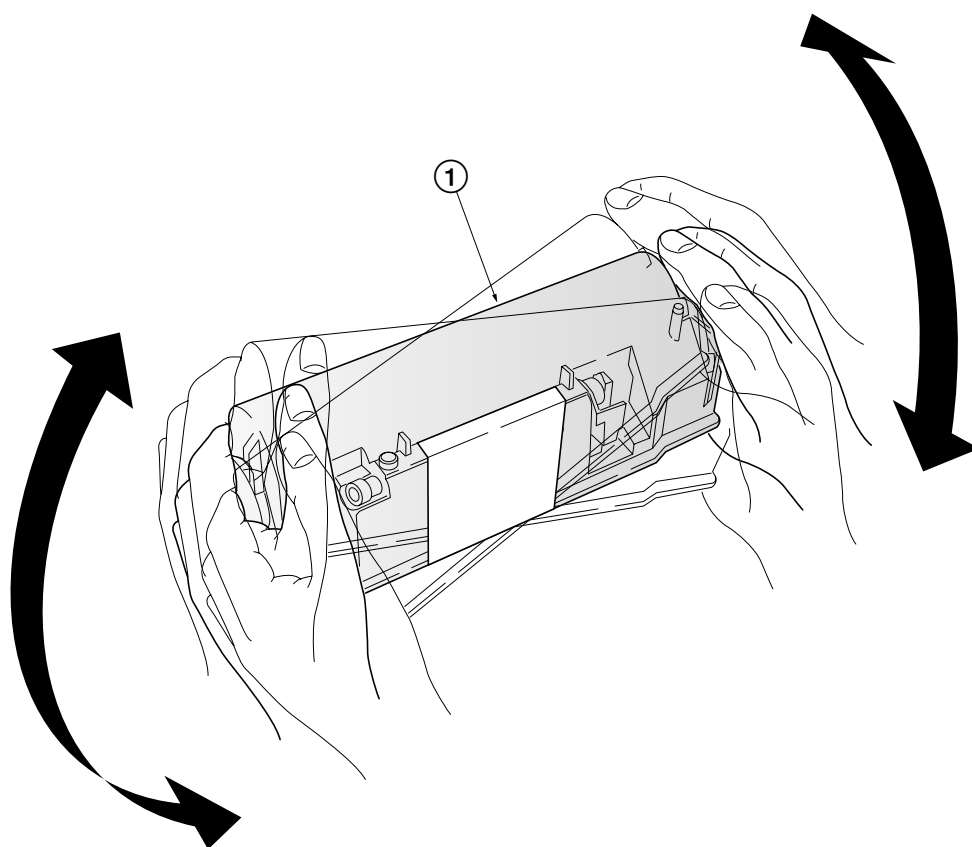

Figure 2-2-1 Shake the toner container

3. Carefully remove the protective seal ②.

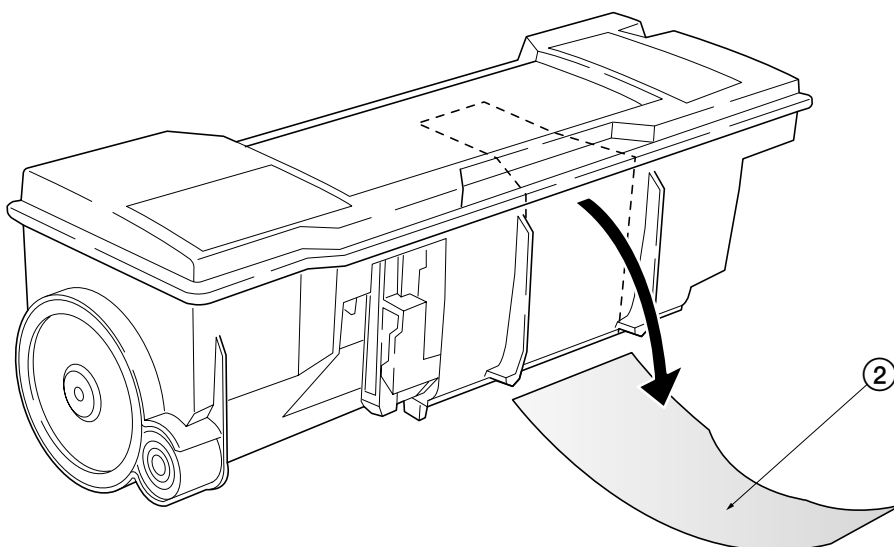

Figure 2-2-2 Removing the protective seal

4. Install the toner container ② into the printer.

5. Push firmly on the top of the toner container ② at the positions marked [PUSH HERE].

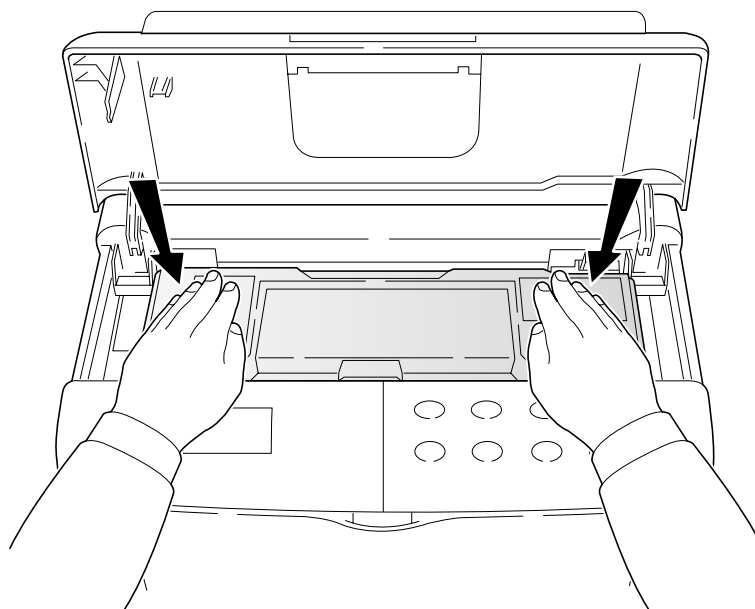

Figure 2-2-3 Installing the toner container

Removing the toner container

To remove the toner container, pull the lock lever (green colored) ① and gently lift the toner container.

NOTE Do not remove the toner container unless you need to do so for servicing, etc.

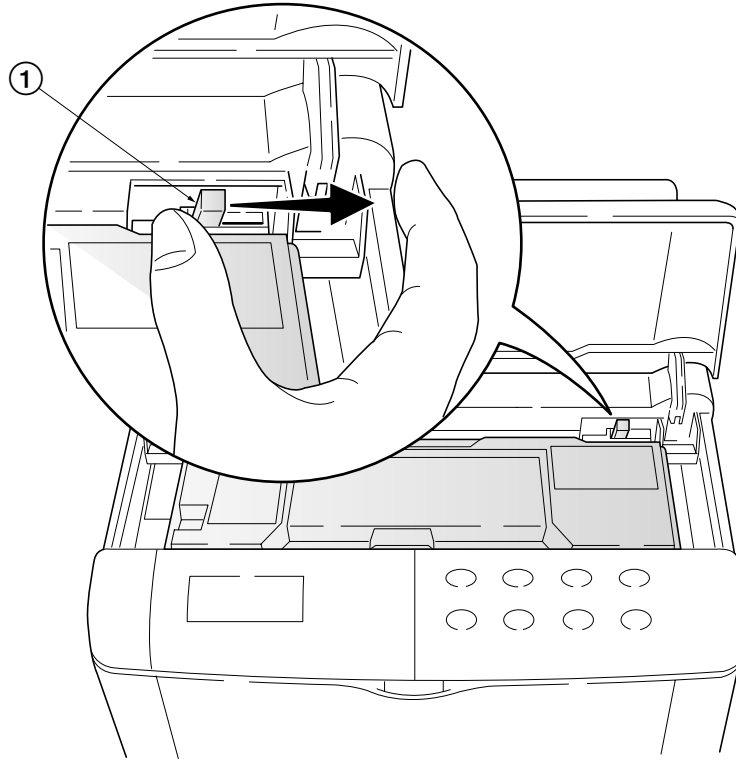

Figure- 2-2-4 Removing the toner container

2-2-2 Installing the waste toner bottle

The waste toner bottle must be installed in the printer. It must be properly fitted inside the left side cover as explained below.

1. Open the cap ① of the waste toner bottle ②.
2. Open the side cover ③ and install the waste toner bottle ② so that it is properly seated in the area under the drum unit.
3. Close the side cover ③.

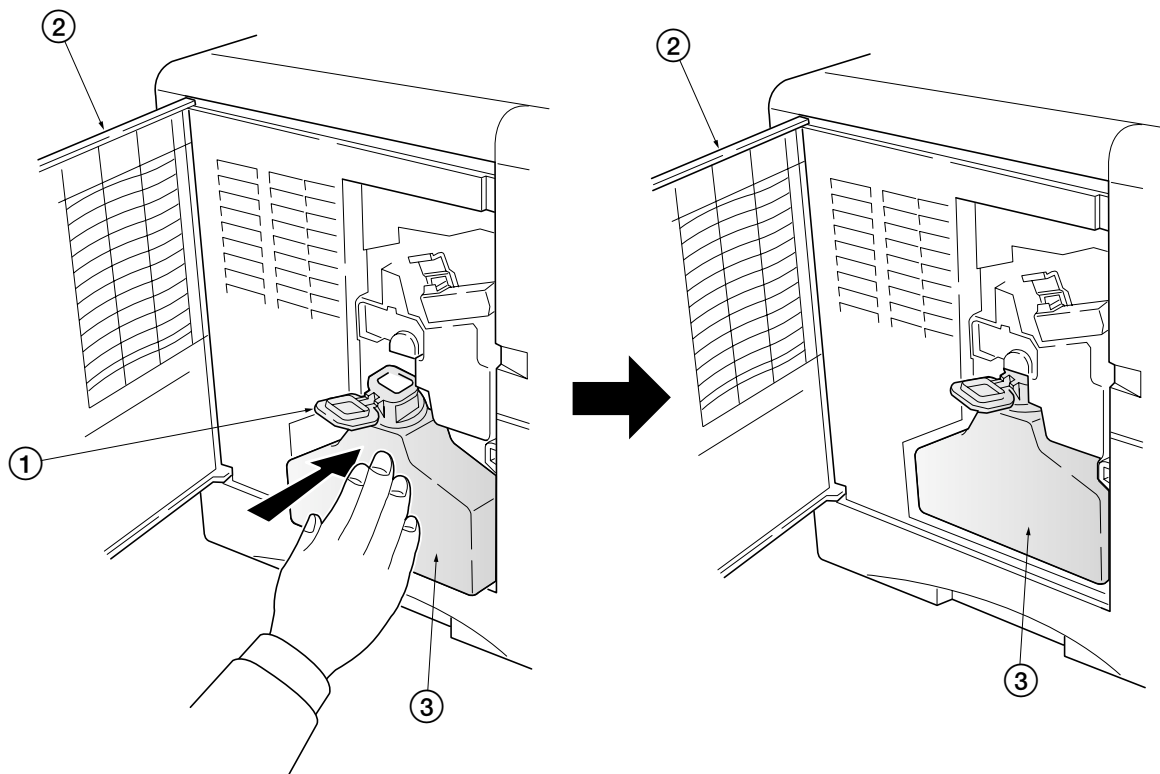

Figure 2-2-5 Installing the waste toner bottle

Removing the waste toner bottle

To remove the waste toner bottle ①, while holding the waste toner bottle ①, press the lock lever ② aside, then gently remove the waste toner bottle ① sideways.

NOTE Do not remove the waste toner bottle unless you need to do so for service, etc.

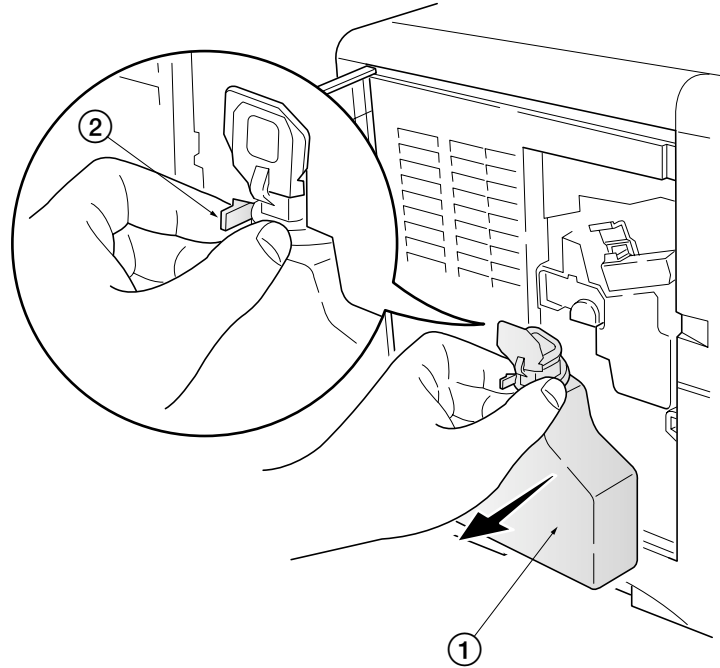

Figure 2-2-6 Removing the waste toner bottle

2-2-3 Developer initialization (automatic)

The printer is shipped from the factory with no toner installed in the developer. In order for the printer to be operable, the developer must be filled with a sufficient amount of toner necessary to continuously support print jobs. This is called developer initialization and automatically executed when the printer is turned on for the first time. Developer initialization takes up to 15 minutes for the original developers (DV-60 for the FS-1800 and DV-61 for the FS-3800) or 8 minutes for the service developer (DV-62 for both models).

NOTE Do not turn printer power off during the developer is initialized. If the printer is switched off in the middle of developer initialization, even after the printer is switch on again, the printer will not automatically resumes developer initialization. Should this be the case, enforce the printer to resume developer initialization in the following manner:

1. While the printer is turned off, press and hold the **GO** and **CANCEL** keys.
2. Turn printer power on.
3. Let go off of the **GO** and **CANCEL** keys for more than 5 seconds.

Developer initialization resumes for the rest of the required total time.

4. Wait until the **READY** indicator is lit and the message display indicates Ready.
5. Make a test print by printing a status page. To print a test page, proceed as follows;

- ① Press the **MENU** key on the printer.
- ② Press the \wedge key or \vee key repeatedly until the message display shows **Print Status** Page.
- ③ Press the **ENTER** key twice.

6. If the status page is printed satisfactorily, setup is complete. If not, investigate whether all step procedures are properly followed.

2-2-4 Expanding the memory (DIMM)

The FS-1800/1800N comes standard-equipped with 8 MB of main memory; the FS-3800/3800N comes with 16 MB of memory. The FS-1800/1800N can be expanded up to the maximum of 264 MB (8 MB + 256 MB), and the FS-3800/3800N can be expanded up to the maximum of 272 MB (16 MB + 256 MB). For all models, expansion should be done using optional DIMMs (Dual In-line Memory Module).

(1) Minimum memory requirements

Printing environment	Resolution			
	300 dpi	600 dpi	1200 dpi	
			Fast mode	Fine mode
PCL6, duplex mode = None	8 MB	8 MB	8 MB	8 MB
PCL6, duplex mode = On	8 MB	8 MB	8 MB	12 MB
KPDL, duplex mode = None	8 MB	8 MB	8 MB	8 MB
KPDL, duplex mode = On	8 MB	8 MB	12 MB	12 MB
PCL6/KPDL resource protection, duplex mode = None	-	10 MB	10 MB	10 MB
PCL6/KPDL resource protection, duplex mode = ON	-	14 MB	14 MB	14 MB

(2) DIMM specifications

Item	Specification
Memory size in MB	16, 32, 64, 128 MB
Number of pins	100 pins
Access speed	66 MHz
Parity	None
Bus width	32 bits

(3) Notes on handling DIMM

Before proceeding to install DIMM, to protect the main board and DIMMs, read the following notes:

NOTE

- Before touching a DIMM, touch a water pipe or other large metal object to discharge yourself of static electricity.
- While doing the work, it is recommended that you wear an antistatic wrist strap.
- Touch the main board and DIMM only by the edges, not in the middle.

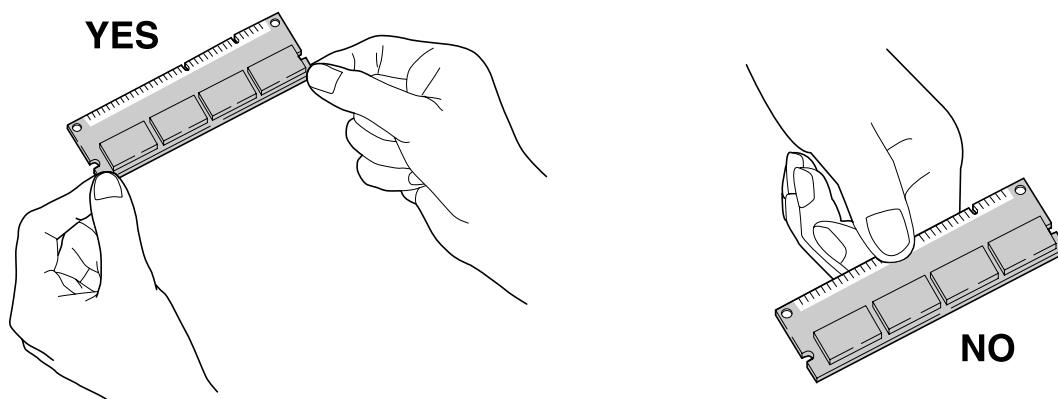

Figure 2-2-7 Handling DIMM

(4) Installing the DIMM

The main board of the printer is equipped with two sockets for installing extra DIMMs.

NOTE A 16 MB DIMM is already installed in one socket for FS-1800N/3800N models.

CAUTION



Be sure that no foreign objects such as metal chips or liquid get inside the printer during installing DIMMs. Operation of the printer during the presence of a foreign substance may lead to fire or electric shock.

WARNING



Before proceeding installation, turn the printer's power switch off. Unplug the printer's power cable and disconnect the printer from the computer or the network.

1. Turn the power switch off.
2. Remove the memory card (CompactFlash) that may be inserted in the memory card slot ① at the left side of the printer.
3. Remove the main board ② by removing the two (plated) screws ③.
4. Pull the main board ② all the way out of the printer.

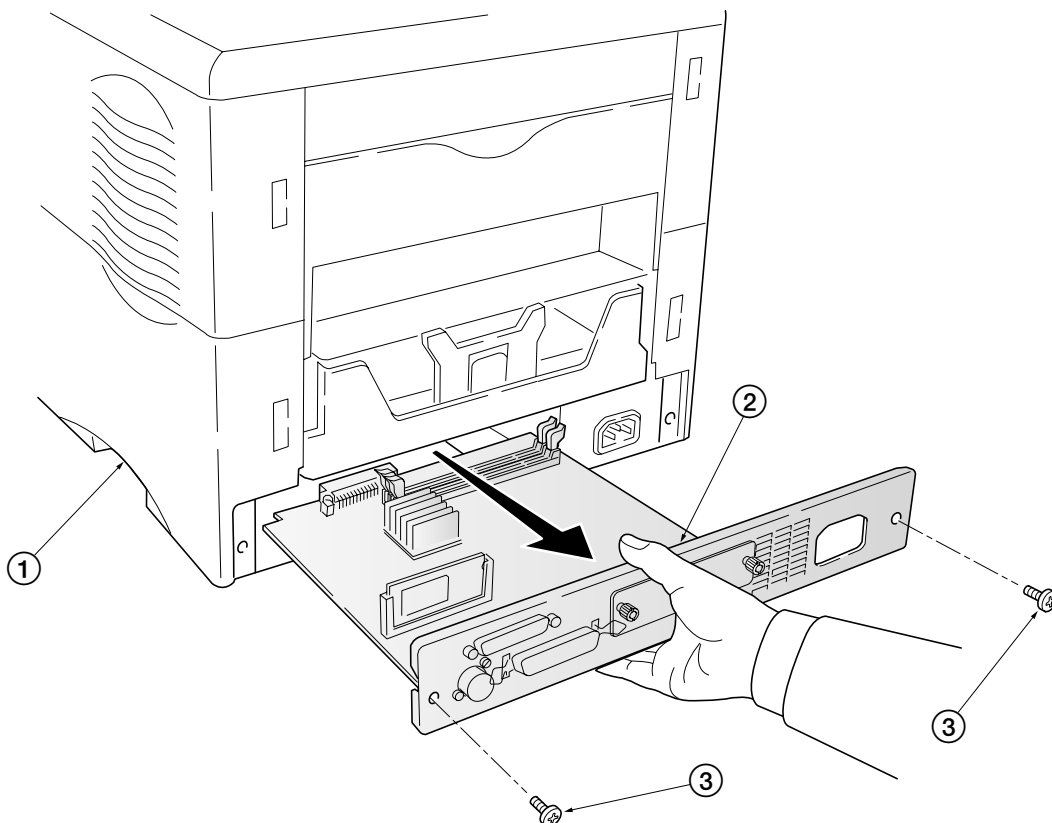

Figure 2-2-8 Removing the main board

5. Open the clips (4) on both ends of the DIMM socket (5).
6. Insert the DIMM (6) into the DIMM socket (5) so that the notches on the DIMM align with the corresponding protrusions in the slot.

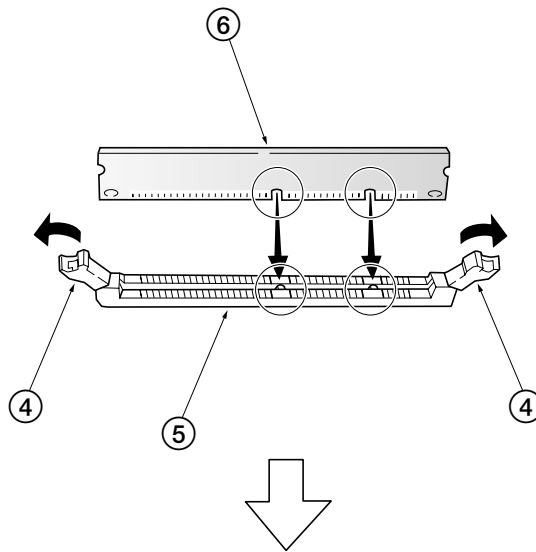

Figure 2-2-9 Inserting the DIMM (1)

7. Close the clips (4) on the DIMM socket (5) to secure the DIMM (6).

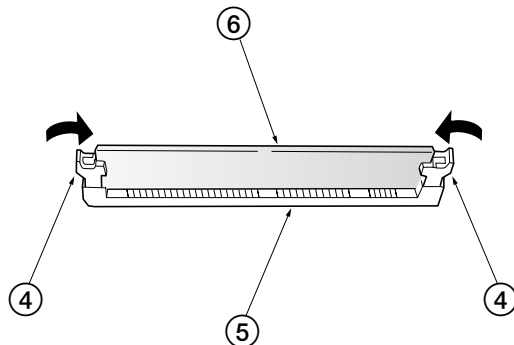

Figure 2-2-10 Inserting the DIMM (2)

(5) Testing the expansion memory

To test the expansion memory, turn printer power on and print a status page. If the installation has been successful, the Available Memory item of the status page will show the expanded memory size corresponding to the amount of memory added.

(6) Installing the option hard disk (Microdrive)

The main board of the printer is equipped with a socket for the hard disk (Microdrive). If the hard disk is installed in the printer, received data can be rasterized and stored on this hard disk. This enables high-speed printing of multiple copies using an electronic sort function. Also, by using the quick copy job function or private/stored job function, desired documents can be printed at any later time. For details of these functions, refer to the printer's *Users Manual*.

CAUTION



Take precautions that no foreign objects such as metal chips or liquid get inside the printer during the installation process. Operation of the printer during the presence of a foreign objects may lead to fire or electric shock.

WARNING



Turn the printer's power switch off. Unplug the printer's power cable and disconnect the printer from the computer or the network.

1. Turn the power switch off.
2. Remove the main board ① from the printer. (See step 2 to 4, on page 2-13.)
3. Install the hard disk ② to the hard disk slot ③.

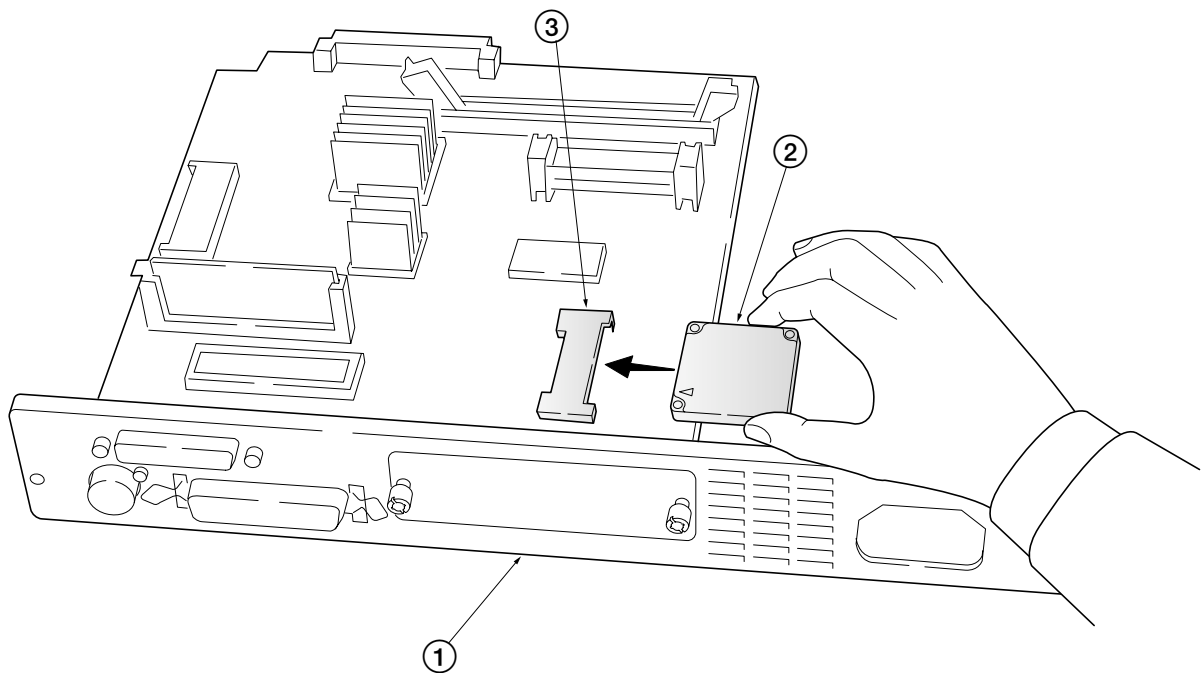

Figure 2-2-11 Installing the option hard disk

(7) Installing the option memory card (CompactFlash)

CAUTION



Do not insert or remove a memory card (CompactFlash) while power is on. If the memory card is removed while the printer is on, damage could result in the printer's electronics or the memory card.

1. Turn the power switch off.
2. Insert the memory card ① in the memory card slot ② at the right bottom of the printer. Insert it face up, connector end first. Push it in all the way.

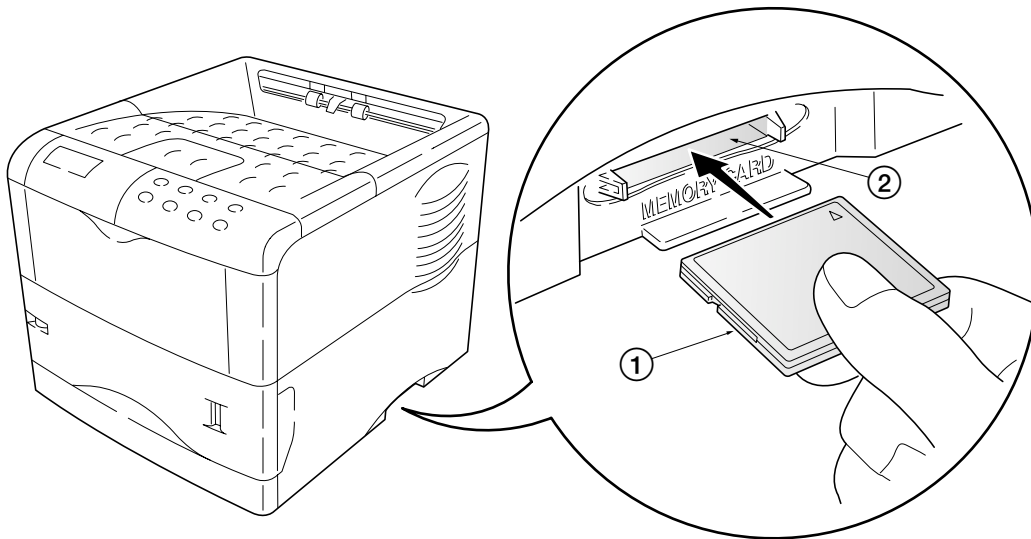

Figure 2-2-12 Installing the option memory card

(8) Installing the option network interface card

The main board of the printer is equipped with a network interface card slot (KUIO-LV type, 3.3 V). The FS-1800N and FS-3800N have a network interface card IB-21 already installed at the factory.

CAUTION



Be sure that no foreign object such as metal chips or liquid get inside the printer during the installation process. Operation of the printer during the presence of a foreign object may lead to fire or electric shock.

WARNING



Turn the printer's power switch off. Unplug the printer's power cable and disconnect the printer from the computer.

1. Turn the power switch off.
2. Remove the two screws (1) then remove the option interface card slot cover (2).
3. Insert the network interface card (3) to the option interface card slot (4).
4. Fix the network interface card (3) by two screws (1).
5. Connect the network cable (5) to the network interface card (3).
6. Set the network address from the printer operator panel. (Refer to the printer's *User's Manual*)

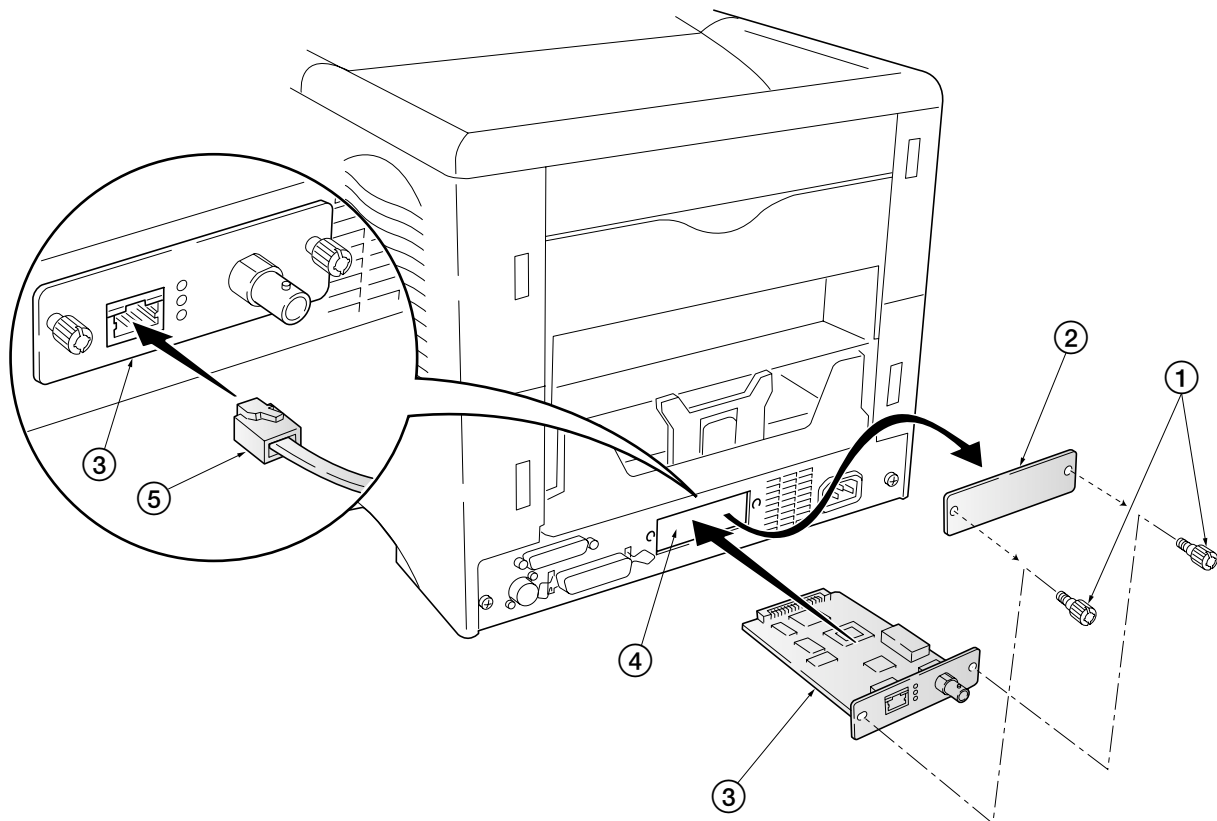

Figure 2-2-13 Installing the option network interface card

2-3 Using the operator panel

This section provides explanation on how to use the printer's operator panel.

For details on operating the printer, refer to the printer's *User's Manual*.

2-3-1 Operator panel

The printer's operator panel has the following indicators, keys and message display. Note that adjustments made using these keys may be overridden by those made from within the application software.

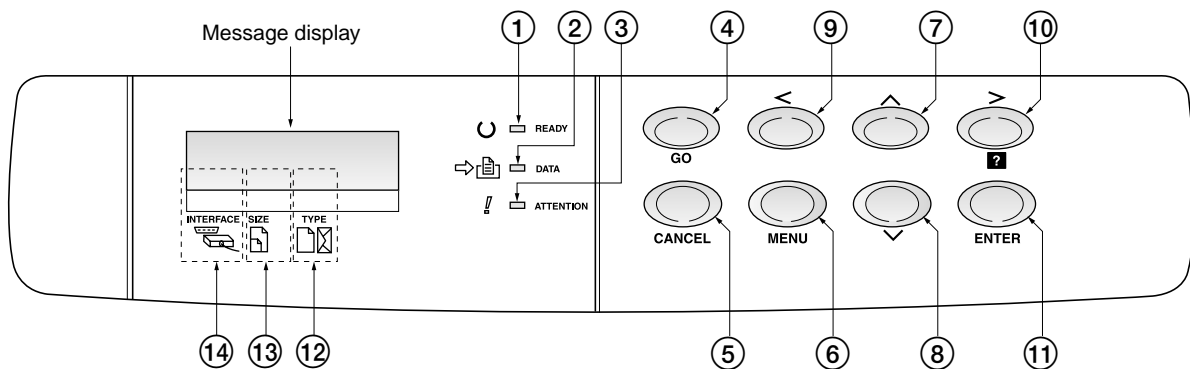

Figure 2-3-1 Operator panel

(1) Indicators and keys

Indicator	Condition	Description
① READY indicator	Flashing	An error has occurred that the user can clear.
	Lit	The printer is on-line and ready to print.
	Off	The printer is off-line. The printers stores but does not print received data. This is also indicates when printing is automatically stopped due to the occurrence of an error.
② DATA indicator	Flashing	Data transfer between the printer and the computer is taking place.
	Lit	Either data is being processed, or data is being written onto the option CompactFlash or Microdrive.
③ ATTENTION indicator	Flashing	The printer needs maintenance attention or the printer is warming up (Please wait).
	Lit	A problem or an error has occurred that the user can clear, for example, paper jam.
	Off	Operations are normal.

Key	Function
④ GO key	<ul style="list-style-type: none"> • Switches the printer on-line and off-line. • Prints and feed out one page.
⑤ CANCEL key	<ul style="list-style-type: none"> • Cancels a printing job. <p>To cancel a print job, proceed as follows:</p> <ol style="list-style-type: none"> 1. Check the message Processing is displayed in the message display. 2. Press the CANCEL key. 3. The message Print Cancel? will appear in the message display and the interface to be canceled will be displayed. Parallel Serial Option (appears only when an [option] network interface card is installed) <p>Press the CANCEL key again if you wish to stop the cancellation of printing.</p> <ol style="list-style-type: none"> 4. Selecting the interface to cancel using the \wedge or \vee key. Then press the ENTER key. Printing from the interface selected will be stopped. The Cancelling data message appears in the message display and printing stops after the printer finishes printing the current page. <ul style="list-style-type: none"> • Resets numeric values, or cancels a setting procedure. • Stops the sound alarm that indicates the occurrence of an error.
⑥ MENU key	<ul style="list-style-type: none"> • Enter menu mode • When pressed during menu selection, terminates the setting and returns to the Ready condition.
⑦ \wedge key	Lets you access the desired item or enter numeric values. In some of the control procedures, the < and > keys are used to enter or exit the sub items.
⑧ \vee key	Enables access to the desired item or entering of numeric values. In some of the control procedures, the < and > keys are used to enter or exit the sub items.
⑨ < key	Used as the < key in the menu selection.
⑩ > key (? key)	<ul style="list-style-type: none"> • Used as the > key in the menu selection. • Displays on-line help messages on the message display when paper jam occur. When pressed in the Ready condition, displays on-line help messages.
⑪ ENTER key	Finalizes numeric values and other selections in menu selection.

(2) Interface indicator

The INTERFACE indicator ⑭ shows which of the printer's interfaces is currently active. It uses the following abbreviations:

Message	Meaning
---	No interface is currently used
PAR	Standard bidirectional parallel interface
SER	Serial interface (RS-232C)
OPT	[Option] network interface card

The PAR , SER , or OPT indicator flashes when the printer is receiving data and remains indicated for the duration of the interface time-out time.

(3) Paper size indicator

The SIZE indicator ⑬ indicates the size of the current paper cassette. Default is Letter size for the U.S.A. and A4 for European countries. While the printer is Processing data to print, the SIZE indicator switches to indicate the paper size selected by the application software.

The following abbreviations are used to indicate paper sizes.

Message	Paper size
A4	ISO A4 (21 × 29.7 cm)
DL	ISO DL (11 × 22 cm) *
A5	ISO A5 (14.8 × 21 cm)
C5	ISO C5 (16.2 × 22.9 cm) *
A6	ISO A6 (10.5 × 14.8 cm) *
b5	ISO B5 (17.6 × 25 cm) *
B5	JIS B5 (18.2 × 25.6 cm)
EX	Executive (7-1/4 × 10-1/2 inches) *
B6	JIS B6 (12.8 × 18.2 cm) *
#6	Commercial 6-3/4 (3-5/8 × 6-1/2 inches) *
LT	Letter (8-1/2 × 11 inches)
#9	Commercial 9 (3-7/8 × 8-7/8 inches) *
LG	Legal (8-1/2 × 14 inches)
HA	Japanese postcard (10 × 14.8 cm) *
MO	Monarch (3-7/8 × 7-1/2 inches) *
OH	Return postcard (20 × 14.8 cm) *
BU	Business (4-1/8 inches) *
CU	Custom size (14.8 × 21 cm to 21.6 × 35.6 cm)

* with only the MP tray feeding

(4) Paper type Indicator

The TYPE indicator ⑫ indicates paper types. The following abbreviations are used to indicate paper types.

Message	Paper type
(none)	Auto
ROUGH	Rough
PLAIN	Plain
LETTERHEA	Letterhead
TRANSPRNCY	Transparency*
COLOR	Color
PREPRINTE	Preprinted
PREPUNCH	Prepunched
LABELS	Labels*
ENVELOPE	Envelope*
BOND	Bond
CARDSTOCK	Cardstock*
RECYCLED	Recycled
CUSTOM1 (to 8)	Custom 1 (to 8)
VELLUM	Vellum*

* with only the MP tray feeding

(5) Message display

The message display gives information in the form of short messages. The six messages listed below are displayed during normal warm-up and printing. Other messages appear when the printer needs the operator's attention as explained in Chapter 6 *Troubleshooting*.

Message	Meaning
Self test	The printer is self-testing after power-up.
Please wait	The printer is warming up and is not ready. When the printer is switched on the first time after the toner container is installed, (Adding toner) also appears.
Ready	
Processing	The printer is ready to print. The printer is receiving data, generating graphics, reading an memory card (CompactFlash)/hard disk (Microdrive), or printing.
Waiting	The printer is waiting for a command that says the job is over before printing the last page. Pressing the GO key allows you to obtain the last page immediately.
Sleeping	The printer is in Sleep mode. The printer wakes from Sleep mode whenever a key on the operator panel is pressed, the cover is opened or closed, or data is received. The printer then warms up and goes on-line. (The time that it takes the printer to enter Sleep mode depends on the Sleep Timer setting.)
Cancelling data	Data inside the printer is being canceled.
FormFeed Time Out	The printer prints the last page after a waiting period.

2-3-2 Menu selection system

The MENU key on the operator panel allows you to use the menu selection system to set or change the printer environment such as the paper source, emulation, etc. Settings can be made when Ready is indicated on the printer message display. The printer obeys the most recently received printer settings sent from the application software, or from the printer driver, which take priority over operator panel settings.

(1) Menu selection and sequence

The following is the hierarchy diagram of the menu selection system of the printer.

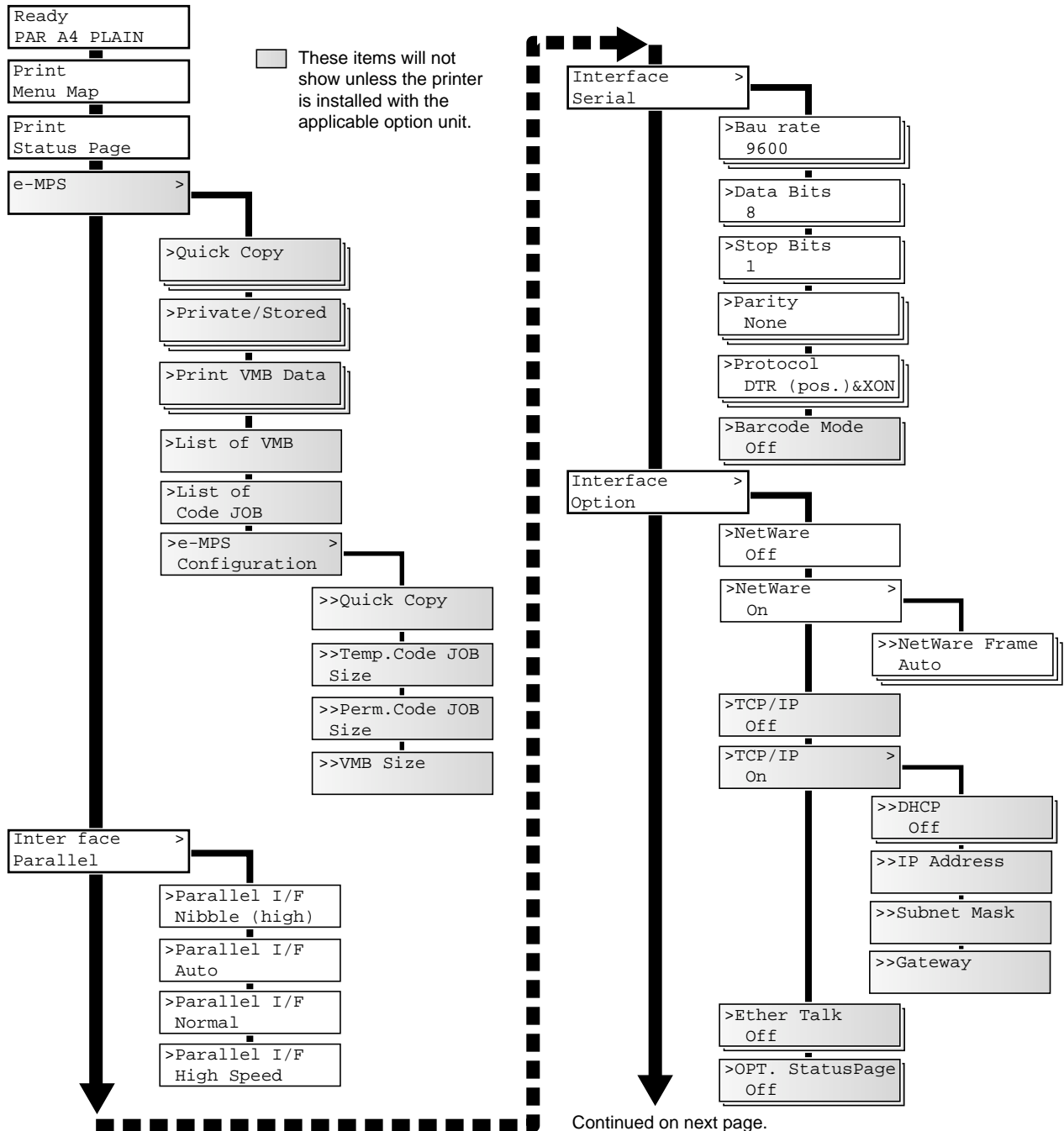

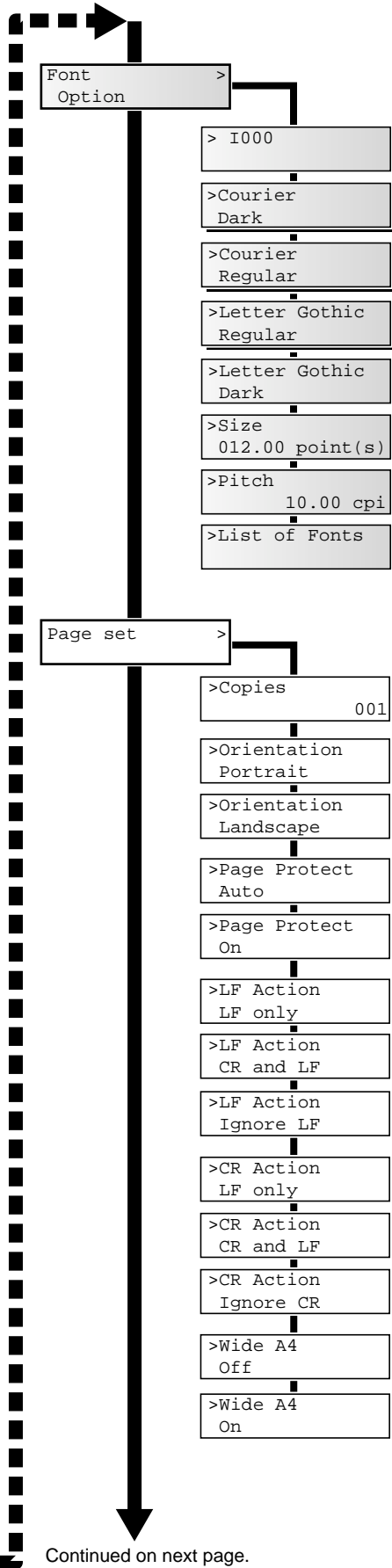
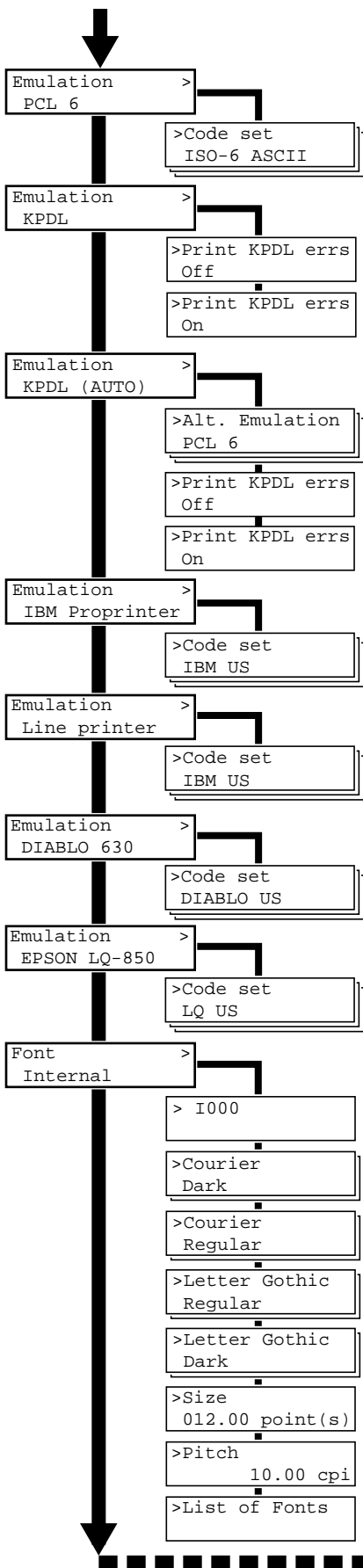

Continued on next page.

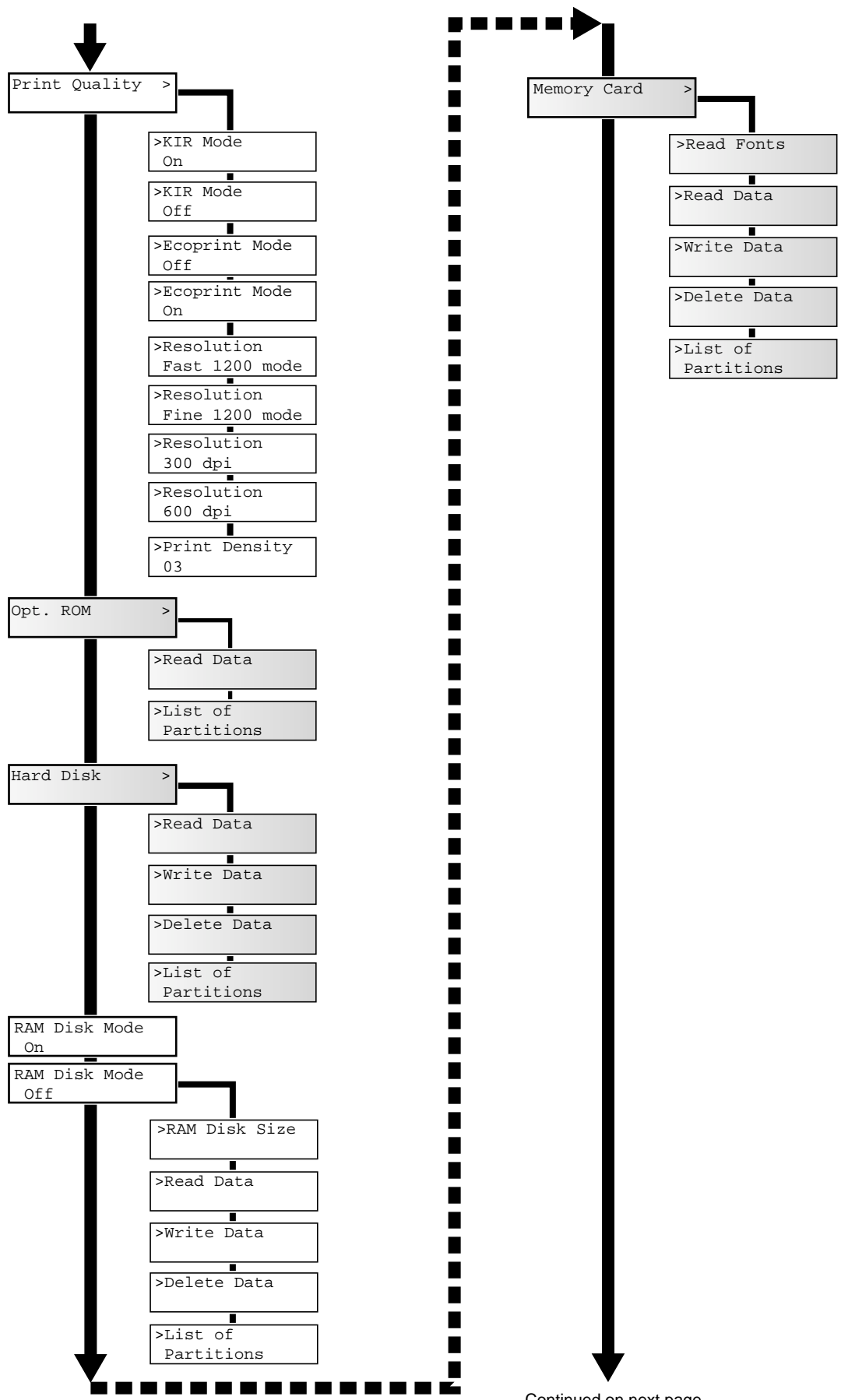

Continued on next page.

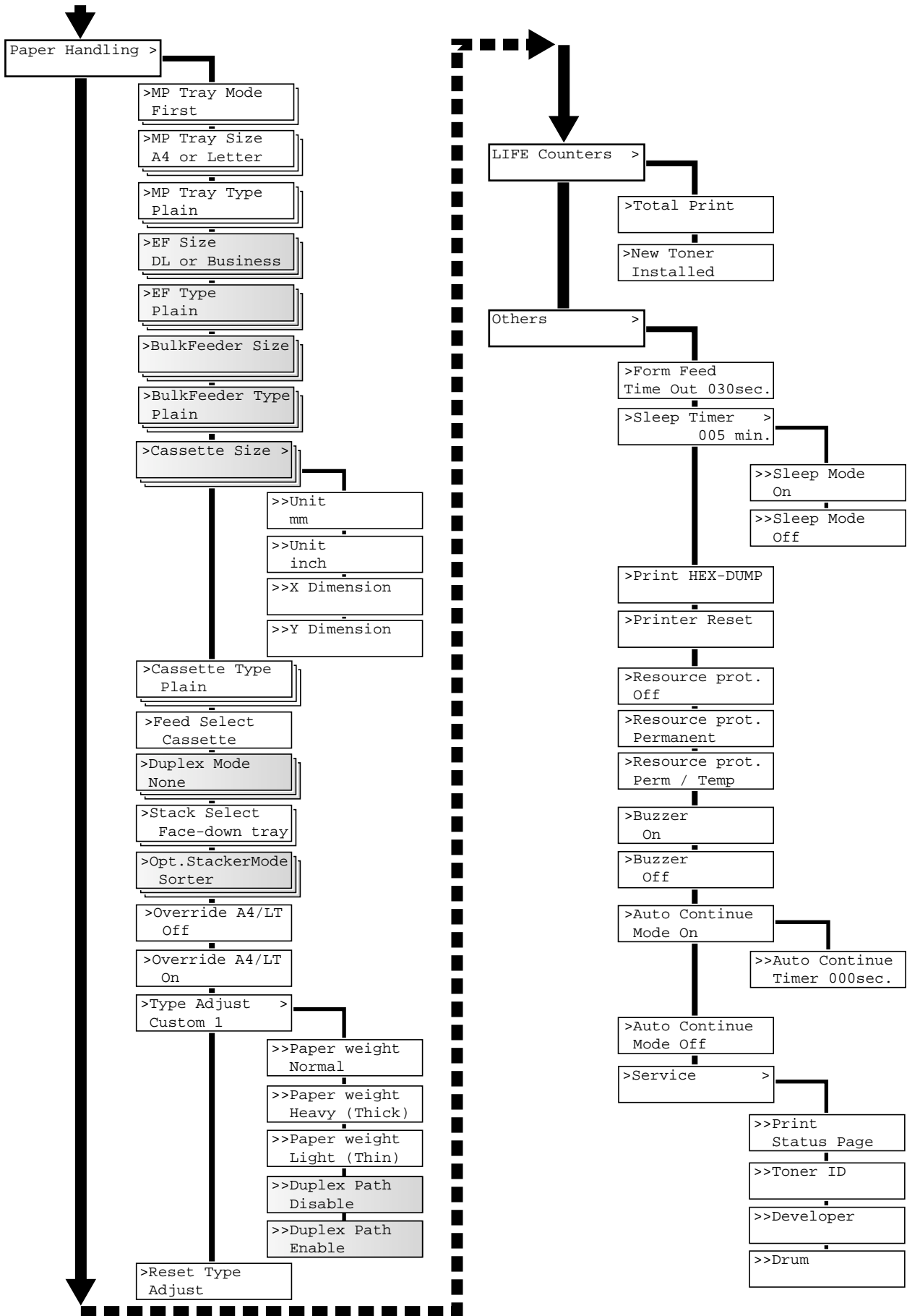

Chapter 3 Maintenance/Adjustments

Chapter 3 Contents

3-1 Maintenance/Adjustments	3-3
3-1-1 Life expectancy of modules	3-3
3-1-2 Toner container	3-4
(1) When to replace the toner container	3-4
(2) Notes on changing the toner container	3-4
(3) Toner container replacement	3-5
(4) Toner saver mode (EcoPrint)	3-6
(5) Replacing the waste toner bottle	3-7
3-1-3 Cleaning the printer	3-8
(1) Main charger unit	3-8
(2) Cleaning the main charger wire and grid	3-9
Main charger wire	3-9
Grid	3-10
(3) Paper feed unit	3-12
(4) Replacing the developer	3-13
Shipping the developer	3-13
(5) Developer initialization (Toner install mode)	3-14
(6) Developer refreshing mode	3-15
(7) Drum cleaning mode	3-16
3-1-4 Updating the firmware	3-17
(1) Firmware program data format	3-18
(2) Downloading the engine and controller firmware	3-18
From the parallel interface	3-18
From the memory card (CompactFlash)	3-20
(3) Downloading operator panel message data	3-21
(4) Downloading errors	3-22

3-1 Maintenance/Adjustments

3-1-1 Life expectancy of modules

The table below shows the nominal life expectancy for modules. Detailed part information for each module (except toner containers) can be found in the separate *Parts Catalog*.

Table 3-1-1 Life expectancy of modules

Module	Model		Nominal life (pages)
	FS-1800/1800N	FS-3800/3800N	
Toner container* ¹	TK-60		20,000
	TK-60E		10,000
Drum unit	DK-60	DK-61	300,000
Developer	DV-60	DV-61	300,000
	DV-62		300,000
Fuser unit	FK-60* ³	FK-61* ³	300,000
Main charger unit	FE-60	FE-61	300,000
Refurbishment kit* ²	MK-60	MK-61	300,000

*¹: User-replaceable

*²: Includes DK, DV, and FK kits and a feed-transfer unit.

*³: Each FK kits have two voltage type for 120 V AC and 220 - 240 VAC.

3-1-2 Toner container

Assuming an average toner coverage of 5 % with *EcoPrint* mode turned off, the toner container TK-60 will need replacing approximately once every 20,000 pages; the toner container TK-60E, approximately once every 10,000 pages.

Kit	Life in pages
TK-60	20,000
TK-60E	10,000

Based on letter or A4 size paper; average print coverage of 5 %

Table 3-1-2 Toner container

NOTE A new printer in which a toner kit TK-60 is installed for the first time, the number of copies that can be printed will be limited to approximately 10,000 pages.

(1) When to replace the toner container

When the printer runs low on toner, *Toner low TK-60* display and **ATTENTION** indicator lit on the operation panel. Be sure to promptly replace the toner container and clean the inside of the printer when this message appears.

If the printer stops printing while *Replace toner TK-60* is display, replace the toner container to continue printing.

(2) Notes on changing the toner container

Observe the following cautions when replacing the toner container:

- Do not attempt to disassemble the old toner.
- Do not attempt to reuse the waste toner inside.
- Keep magnetic media such as floppy disks away from the toner container.
- Be sure to clean the parts as instructed in section 3-1-1 *Cleaning the printer* on page 3-8 at the same timing of replacing toner container.
- Use of the Kyocera toner kit TK-60/TK-60E is highly recommended for the optimum operation of the printer.

(3) Toner container replacement

To replace the toner container, open the top cover. Pull the lock lever ① to the right and gently lift the old container ②.

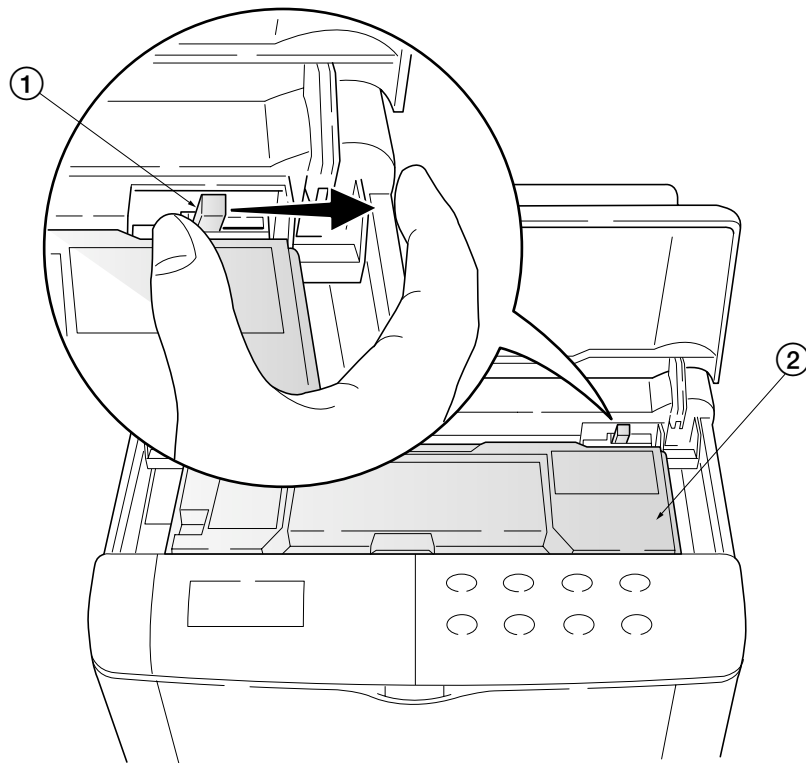

Figure 3-1-1 Removing the old toner container

Put the old toner container in the supplied plastic bag ③ and dispose of it.

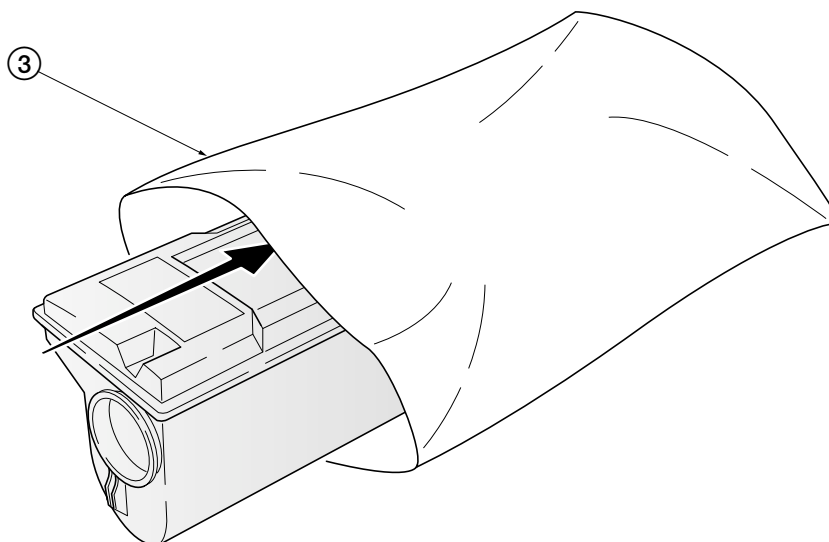

Figure 3-1-2 Disposal of the old toner container

NOTE Although the toner container is made from non-harmful, flammable material, be sure to dispose of it according to laws and regulations.

See also the instructions provided in chapter 2, *Installing the toner container* on page 2-5 to complete installation of the new toner container.

(4) Toner saver mode (*EcoPrint*)

The *EcoPrint* enables to reduce the amount of toner consumed on the page so as to save printing costs by drastically extending the toner container life. *EcoPrint* mode is factory-set to off and turned on by using the menu system of the printer operator panel. For details, see the printer's *User's Manual*.

(5) Replacing the waste toner bottle

Note that the printer has a sensor to monitor the presence of the waste toner bottle. The printer does not operate without a waste toner bottle installed.

For the reference, the waste toner bottle can hold up to 100 g of waste toner. The nominal amount of waste toner derived after 10,000 pages of printing is 20 to 30 g (Letter or A4 size paper; average print coverage of 5 %).

Open the side cover. While holding old the waste toner bottle ①, press the lock lever ② in the right ward direction. Then gently pull out the waste toner bottle ①. Close the cap ③ of waste toner bottle ① after removing from the printer. To avoid toner spilling, place the capped waste toner bottle ① in the plastic bag ④ supplied before forwarding to proper disposal.

Locate the new waste toner bottle in the toner kit, and install it in the printer according to section 2-2-2 *Installing the waste toner bottle* on page 2-8.

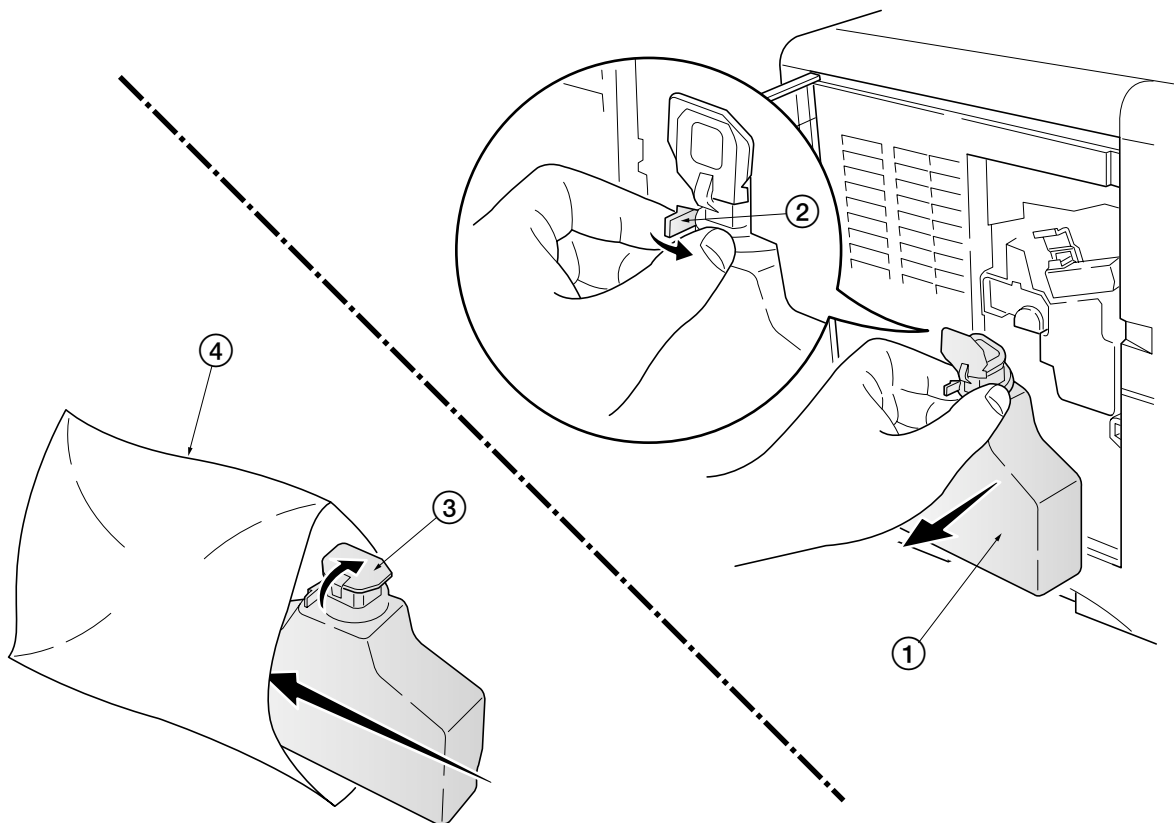

Figure 3-1-3 Removing the old waste toner bottle

3-1-3 Cleaning the printer

To avoid print quality problems, the following printer parts must be cleaned with every toner container replacement.

(1) Main charger unit

The main charger unit should be cleaned in its two parts, the main charger wire and grid (See figure below.) whenever the toner container is changed. Cleaning of the main charger can be done without needing any tools thanks to its self-cleaning system.

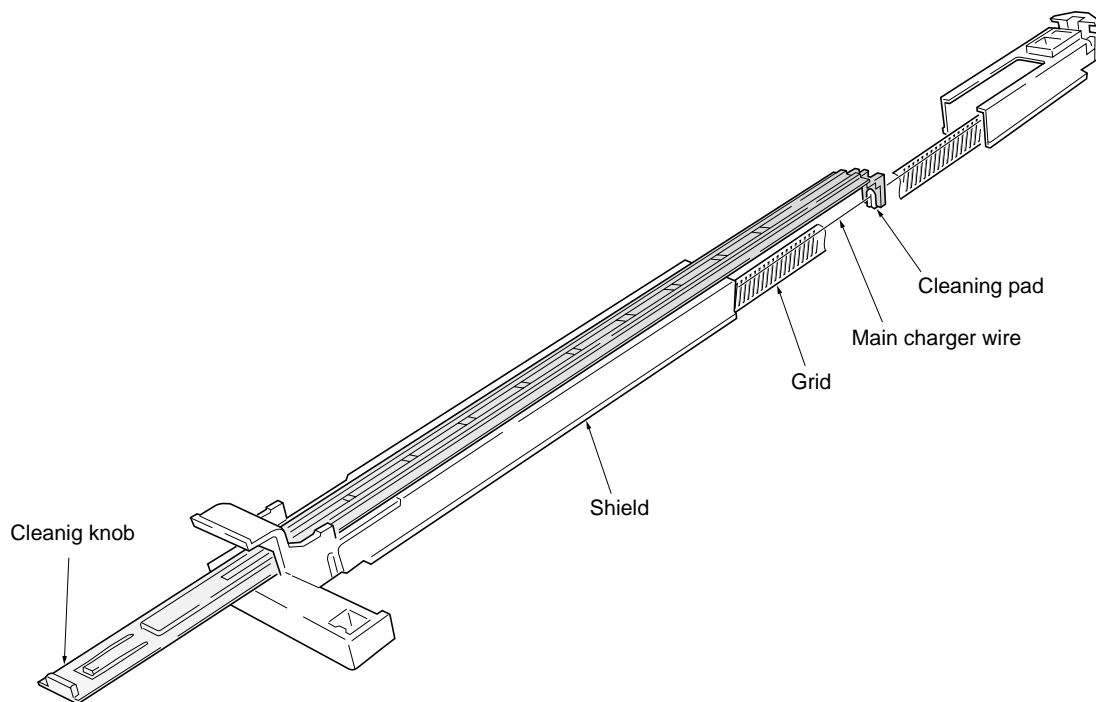

Figure 3-1-4 Main charger unit

(2) Cleaning the main charger wire and grid

Main charger wire

1. Open the side cover ①.
2. Pull the cleaning knob (green colored) ② slowly in and out a few times.

NOTE Cleaning knob pulls a cleaning pad inside the drum unit along the main charger wire.

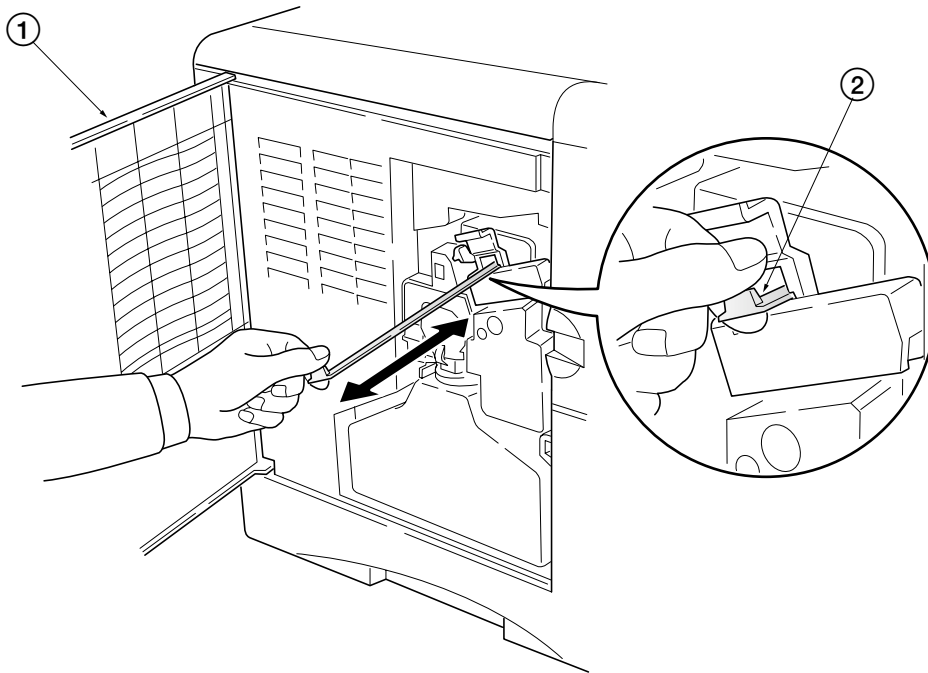

Figure 3-1-5 Cleaning the main charger wire

Grid

1. Take the grid cleaner ① from protective bag ② in the new toner kit and remove the cap ③.

NOTE The grid cleaner pad is impregnated with water. Perform the following cleaning procedure before the pad dries.

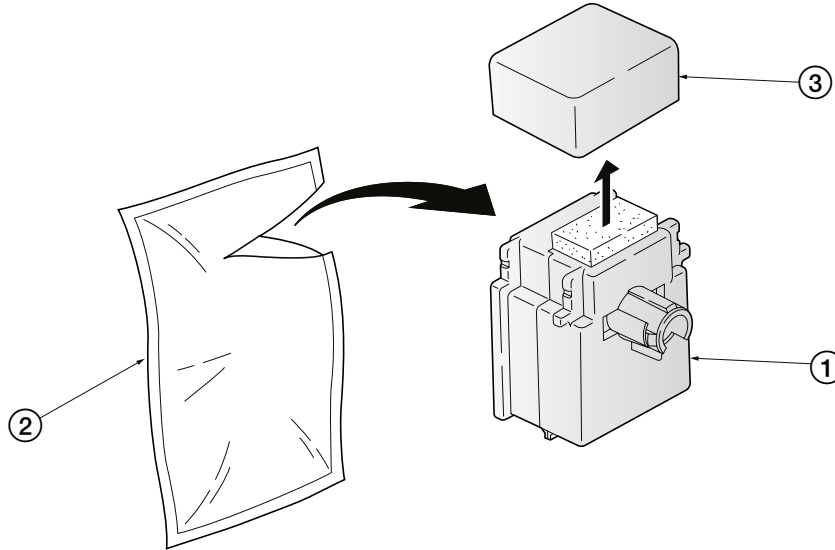

Figure 3-1-6 Grid cleaner

2. Attach the grid cleaner ① to the drum unit ③ with the pad uppermost as shown in the diagram.

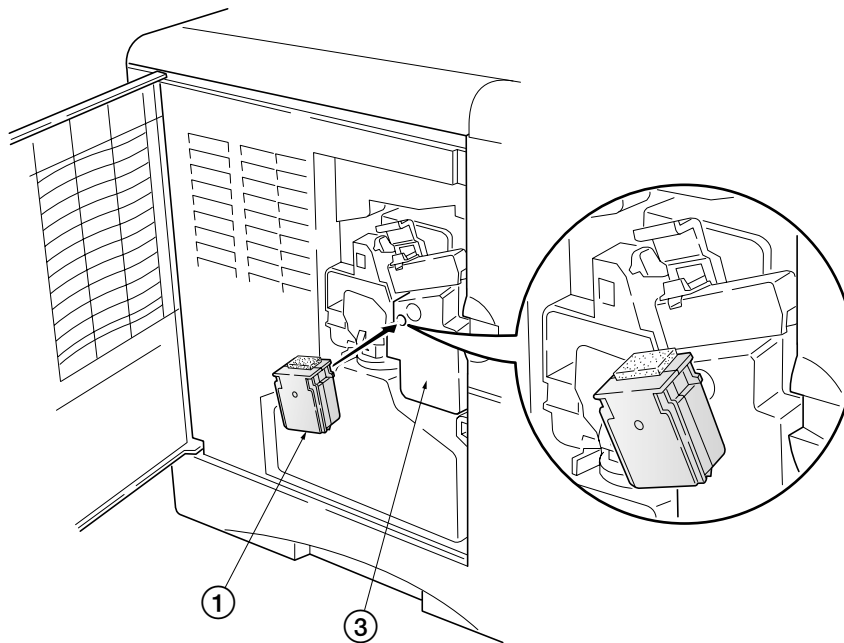

Figure 3-1-7 Attaching the grid cleaner

3. After attaching the grid cleaner, repeat the action of slowly pulling out and then pushing back in the main charger unit at least 5 times. It is easier to pull out the main charger with its front end raised slightly as shown in the figure. The grid part underneath the main charger is cleaned by the wet pad of the grid cleaner.

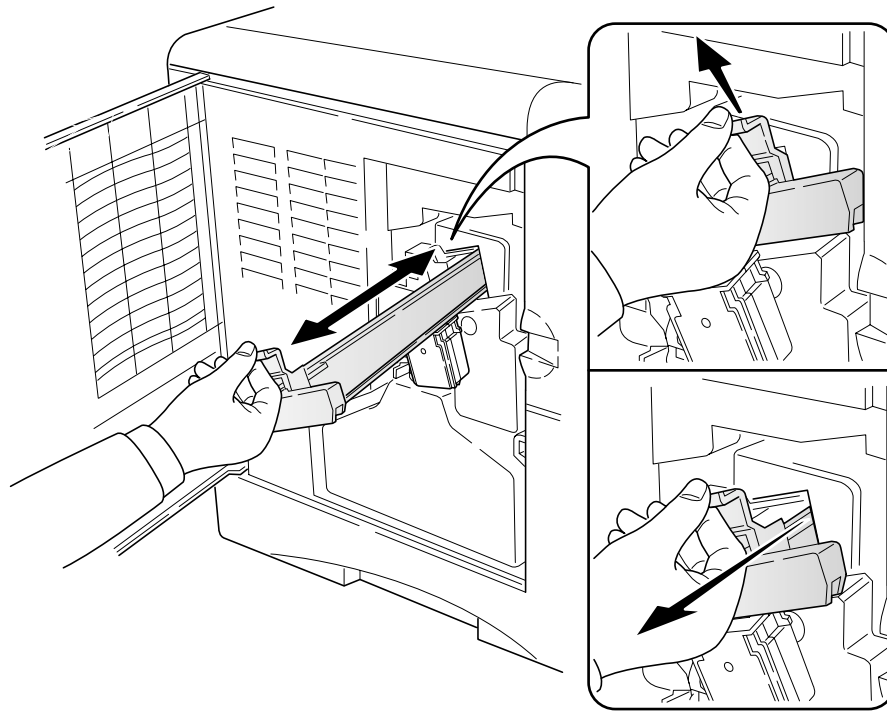

Figure 3-1-8 Cleaning the grid

4. Remove the grid cleaner from the printer and dispose of it. The grid cleaner is not reusable.

(3) Paper feed unit

To avoid print quality problems due to paper dust and debris, clean the paper feed unit in the following manner:

Pull the paper feed unit release lever (1) up and draw the paper feed unit all the way out until it stops. Wipe the paper dust on the upper registration roller (2) and the paper ramp (3) using the wiper cloth (4) included in the toner kit.

CAUTION



Do not touch the transfer roller (5) (black sponge roller) when wiping the paper ramp (3).

Area (6) below is factory-applied with lubricating oil. When cleaning the paper feed unit (7), do not use alcohol to clean this area. If the oil is completely removed, an incorrect action of the MP tray paper sensor ((8), actuator) will result.

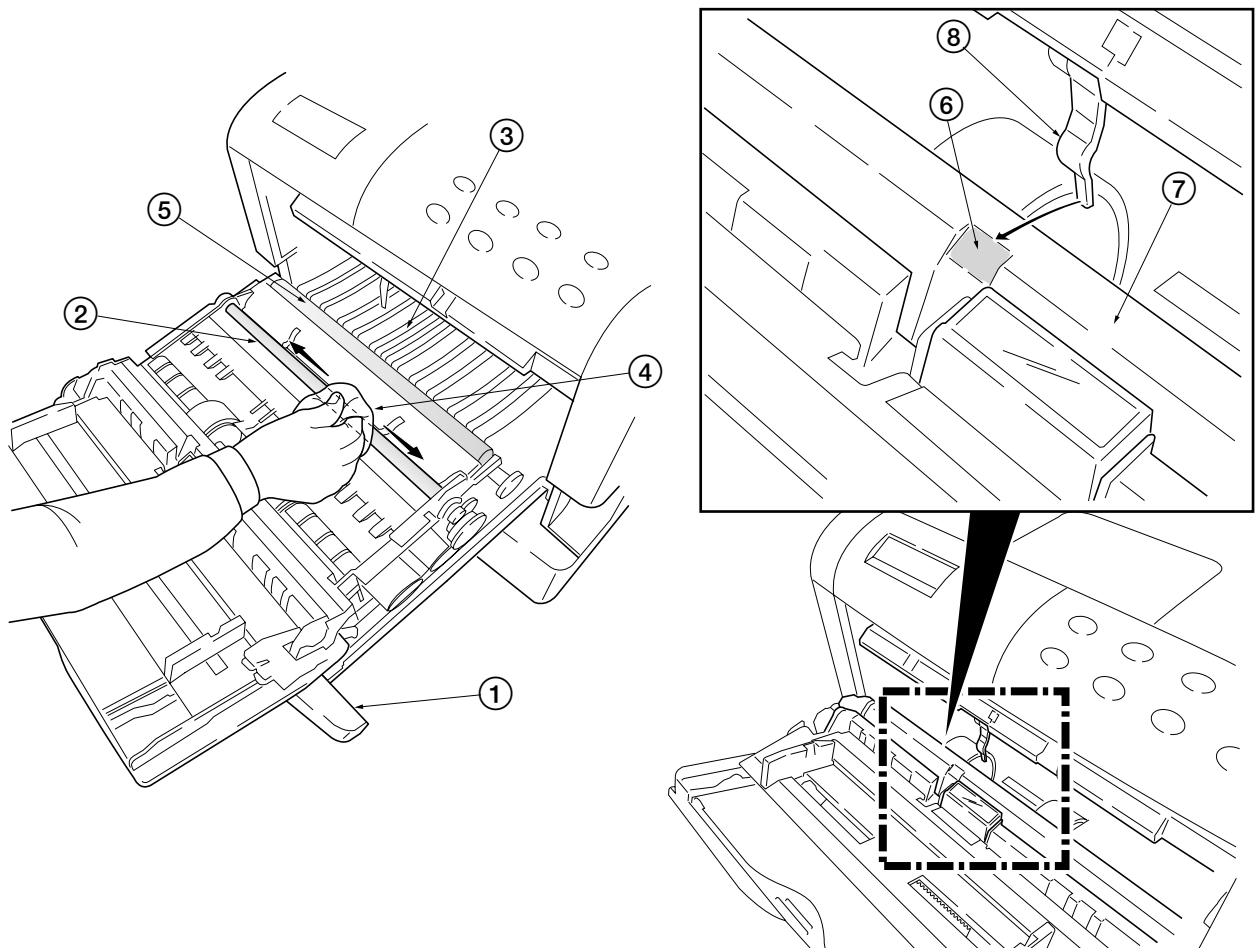

Figure 3-1-9 Cleaning the upper registration roller and the paper ramp

(4) Replacing the developer

To remove the developer unit from the printer for shipment or replacing to a new one, it should be handled following the instructions below.

After the replacement, new developer needs to be initialized in manner explained in the section *Developer initialization (Feeding toner into the new developer)* on next page.

Shipping the developer

The printer is supplied with a plastic bag that should be retained for future shipment of the developer.

To pack the developer ① in the packing carton, first flap down the magnet roller protective cover ②. Put the developer ① into the supplied plastic bag ③. Put the developer ① on the developer install position ④ of packing carton.

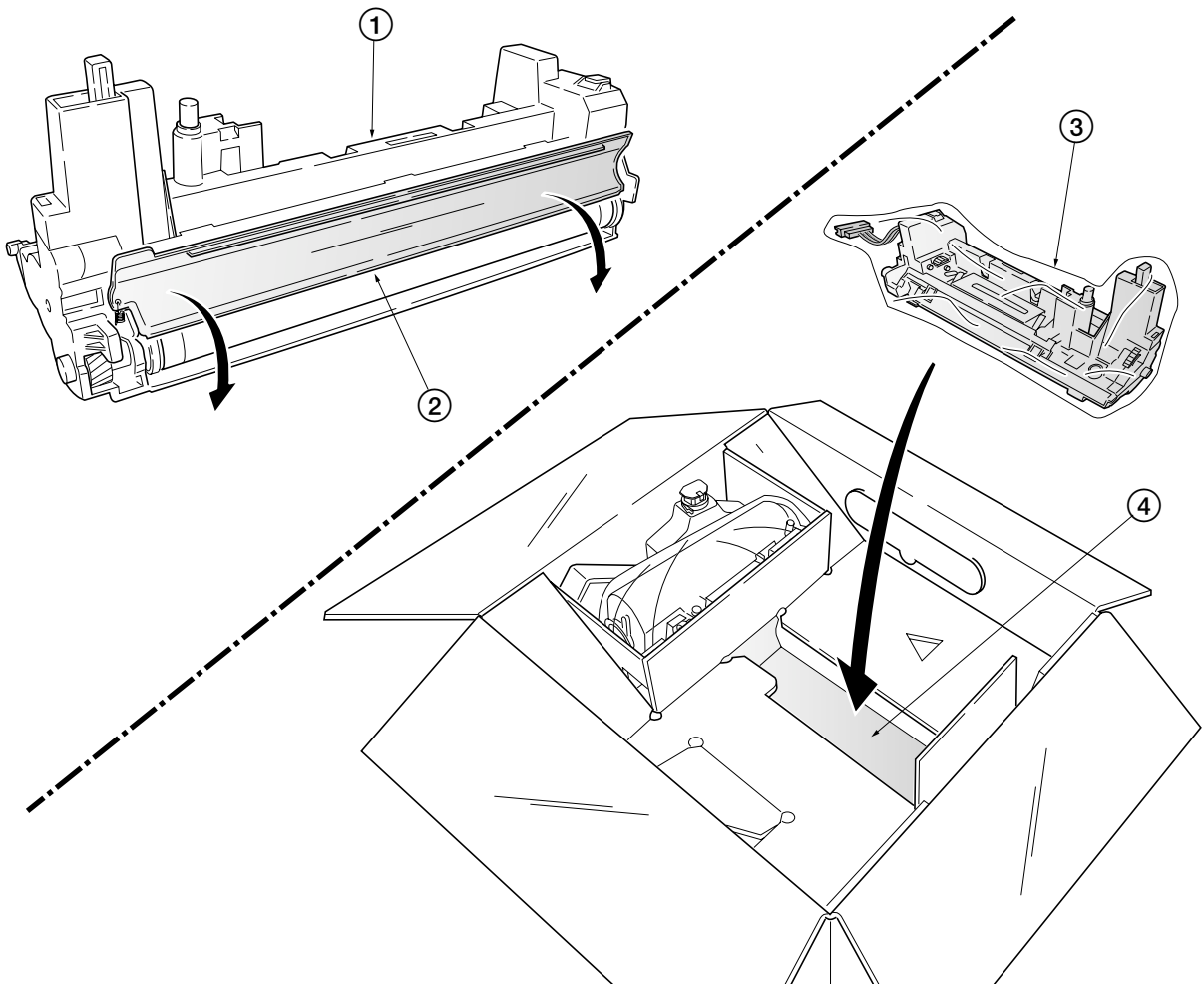
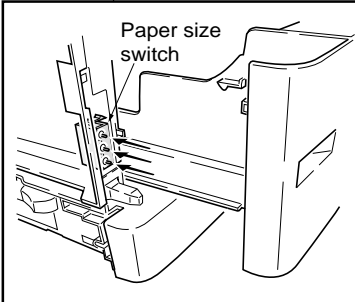

Figure 3-1-10 Shipping the developer

(5) Developer initialization (Toner install mode)

The new developer unit is shipped from the factory with no toner contained. The developer can be automatically replete with toner when a toner container is installed onto it and the printer is turned on. However, because the toner reservoir in the developer has a large capacity, it requires a lengthy period of time until a substantial amount of toner has been fed to get the printer ready. (A new developer needs approximately 100 g for triggering the sensor inside.)

A great many seconds of time for this is greatly deducted by using the service menu in the printer's mode select routine as accessed by its operation panel. Follow these steps to use this feature, top to bottom (For details, refer to section 2-3 *Using the operator panel* on page 2-19).

Perform in sequence	Display to show	Remarks
① Press the MODE key.		
② Press the \wedge key (repeatedly).	Others >	
③ Press the > key.		
④ Press the \wedge key (repeatedly).	>Service >	
⑤ Press the > key.	>>Developer	
⑥ Press the ENTER key.	>>Developer?	
⑦ Press the ENTER key.		The printer enters the service mode and the developer and toner motor are continually activated.
<div style="display: flex; align-items: center;">  <div style="margin-left: 20px;"> <p>Note: To cancel the toner install mode during in this mode first turn power off, press and hold all three paper size switches, and turn power on until message changes to Ready.</p> </div> </div>		
⑧ Turn printer power off then on.	Ready	

When printer power is turned on again, the printer continually engages in this mode for a period of approximately 15^{*1}/8^{*2} minutes, after which the printer reverts to the ready state.

*1: Developer DV-60/DV-61 *2: Developer DV-62

(6) Developer refreshing mode

This mode is used to eliminate light printing problems. Once activated, the toner in the developer unit is enforced to be sent onto the drum unit, collected back in the waste toner bottles. At the same time the new toner is fed in the developer so that the developer unit is refilled with new toner. Once activated, the printer will keep engaged in this mode and be running for an average of 60 minutes.

NOTE The amount of the (old) toner replaced and collected in the waste toner bottle will be approximately 100 g. The waste toner bottle consequently become full and must be replaced with a new one.

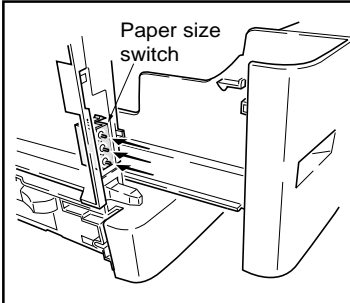
Perform in sequence:	Display shows:
① Turn printer power on.	
② Make sure the printer is Ready. (Connect the printer to the computer using the parallel interface.)	Ready
③ At the DOS prompt, send the following command to the printer: <code>>ECHO !R!EXTP 7,92;EXIT;>PRN</code>	
④ Turn printer power off, then on. The toner refreshing mode will begin. The old toner will be rejected in the first approximately 20 minutes, followed by another 40 minutes interval in which the new toner is fed in the developer unit.	Please Wait (Adding toner)
<div style="display: flex; align-items: center;">  <div style="margin-left: 20px;"> <p>Note: To cancel the toner refreshing mode first turn power off, press and hold all three paper size switches, and turn power on until message changes to Ready.</p> </div> </div>	
⑤ Check that the display reverts to Ready. (If the display shows “Call service person99”, refer to section 6-1-2 <i>Diagnostic (Service error messages)</i> on page 6-11.)	Ready
⑥ Print a page to check the print density. (If the print density is too dark (gray background), change the “Print Density” setting in the menu selection to 1 or 2 steps lighter. (Default is 3.) Refer to printer’s <i>User’s Manual</i> for details.)	Print density 03

(7) Drum cleaning mode

This mode enforces the printer to rotate the drum against the cleaning roller inside the drum unit for a predetermined period of time. The cleaning roller then removes dust and debris that may have resulted from dew condensation on the drum.

The printer automatically activates the drum cleaning mode based on the environmental conditions as the temperature/humidity sensor detects. The time required to complete the drum cleaning mode varies depending on the current setting for the sleep timer and will be deactivated during the developer initialization.

The drum cleaning mode is also activated manually by following the steps below:

Perform in sequence	Display to show	Remarks
① Press the MODE key.		
② Press the ∧ key (repeatedly).	Others >	
③ Press the > key.		
④ Press the ∧ key. (repeatedly).	>Service >	
⑤ Press the > key.	>>Drum	
⑥ Press the ENTER key.	>>Drum?	
⑦ Press the ENTER key.		Drum is cleaned by the cleaning blade in the drum unit. If paper is present on the MP tray, the drum is also cleaned by that the paper which is fed automatically and stops at the transfer roller.

3-1-4 Updating the firmware

Updating the engine and controller firmware is possible by downloading the firmware through the parallel interface or through the memory card (CompactFlash). These firmware programs are directly overwritten in the flash ROM (U202) on the printer's engine board or system DIMM [board KP-777*1/KP-858*2] (Flash ROM type only) on the main board. *1: FS-1800/1800N *2: FS-3800/3800N

The operator panel message in different languages can also be downloaded, but through the parallel interface only.

NOTE

Controller system DIMM: Firmware update is possible with flash ROM type system DIMM [board] only. Masked type system DIMM [board] can not be overwritten. Check the type of the system DIMM [board] used on the main board by referring to the figure below.

If the DIMM has a Kyocera logo and firmware version label, the DIMM is a masked-type and can not be updated. To update firmware for this type of system DIMM, replace the DIMM.

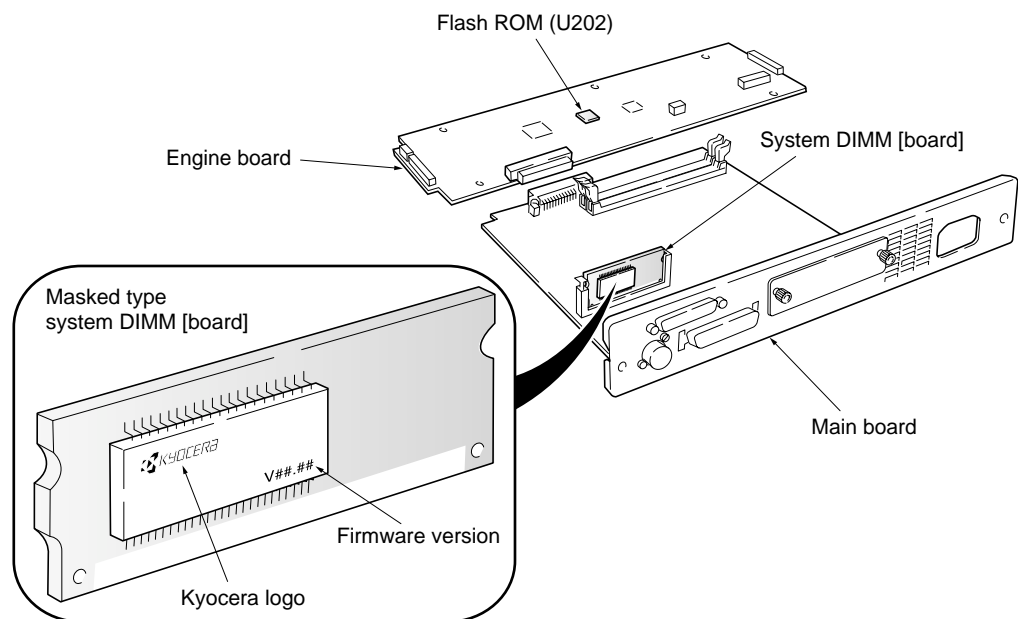

Figure 3-1-11 Engine flash ROM (U202) and masked type system DIMM [board]

Engine flash ROM: The engine flash ROM (U202) is directly mounted on the engine board. Updating the engine firmware is possible only by downloading the data in the manner described in the following sections.

Kyocera supplies the following types of data for updating firmware of the different purposes:

- Controller firmware
- Engine firmware
- Operator panel message data

(1) Firmware program data format

The data to be downloaded are supplied in the following format:

de3730.dat

① ② ③ ④

Identifies...		
①	de	Engine firmware data System firmware data
	dm	Operator panel message data
②	37	FS-1800 and FS-1800N
	38	FS-3800 and FS-3800N
③	30	Version of data (2 to 4 digits)
④	dat	Engine or Controller firmware data
	dan	Operator panel message data for Danish
	swe	Operator panel message data for Swedish
	Ita	Operator panel message data for Italian
	spa	Operator panel message data for Spanish
	por	Operator panel message data for Portuguese
	rus	Operator panel message data for Russian
	pol	Operator panel message data for Polish
cze	Operator panel message data for Czech	

(2) Downloading the engine and controller firmware

From the parallel interface

This section explains how to download firmware data from the parallel interface.

The engine and controller firmware data are downloaded using the same command. The printer system can automatically recognize whether the data is overwritten for the engine or the controller firmware.

CAUTION



Downloading the controller firmware takes several minutes. Do not turn power off during downloading.

NOTE

The computer that MS-DOS is usable is necessary for a download from parallel interface. It is necessary for a computer to be connected to a printer with a parallel cable.

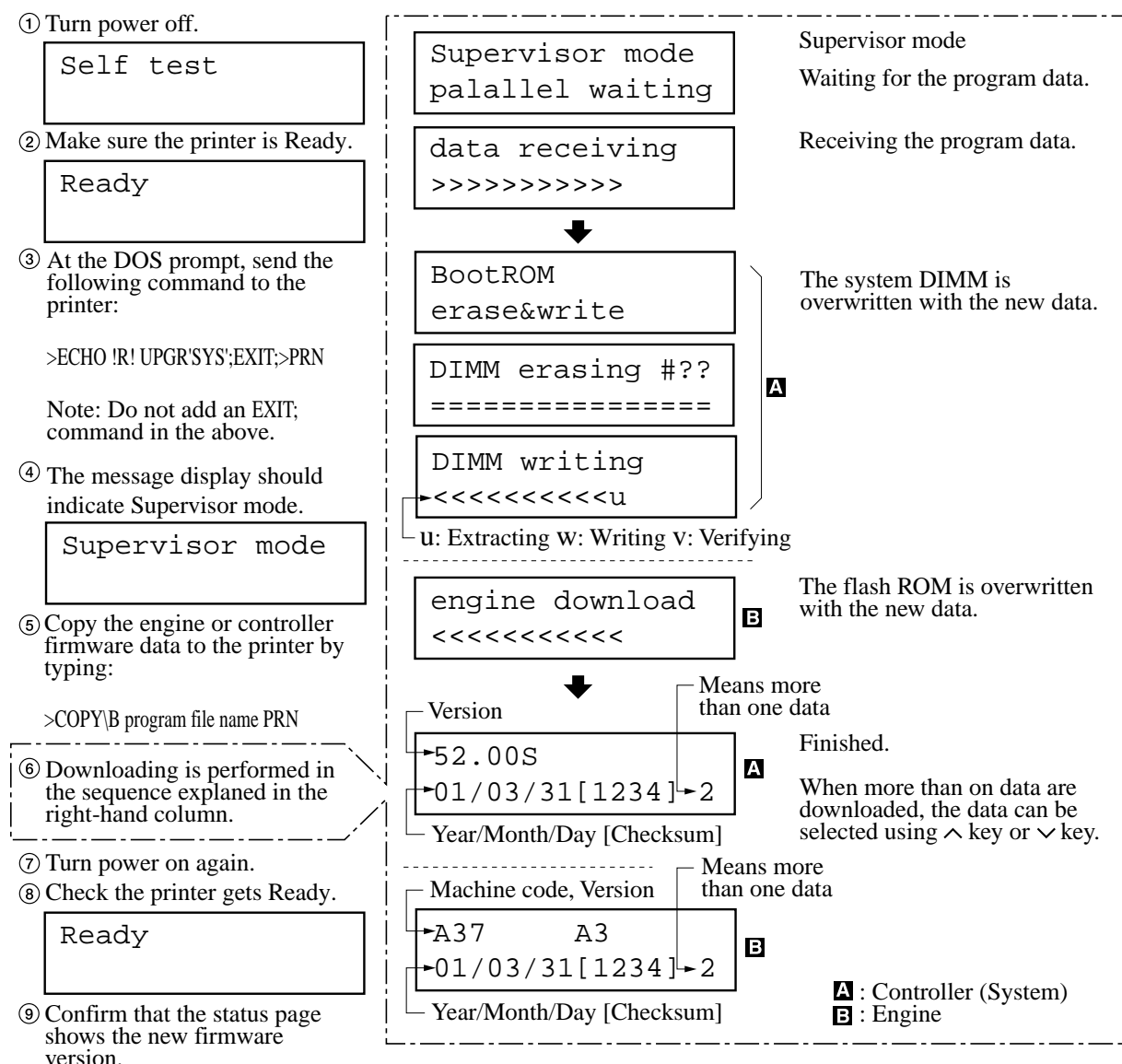

Confirm that the status page shows the new engine firmware or controller firmware version (See Appendix B on page B-4).
If the message display indicates Call service personDn (n=0, 1, ...), refer to section *Downloading errors* on page 3-20.

From the memory card (CompactFlash)

To download data written in a memory card (CompactFlash) to the printer, proceed as explained in this section.

CAUTION



Downloading engine or controller firmware takes several minutes. Do not turn power off during downloading. If downloading is interrupted by an accidental power failure, etc., the system DIMM may have to be replaced.

NOTE

The system or engine firmware program data must be stored to the root directory of the memory card (CompactFlash).

① Turn power off.

② Insert the memory card (CompactFlash) in the printer's memory card slot.

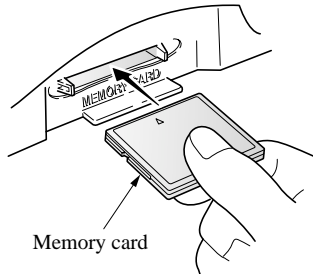

③ Turn power on.

Self test

④ Downloading is performed in the sequence explained in the right-hand column.

⑤ Turn power off.

⑥ Remove the memory card.

⑦ Turn power on.

⑧ Check the printer gets Ready.

Ready

⑨ Confirm that the status page shows the new firmware version.

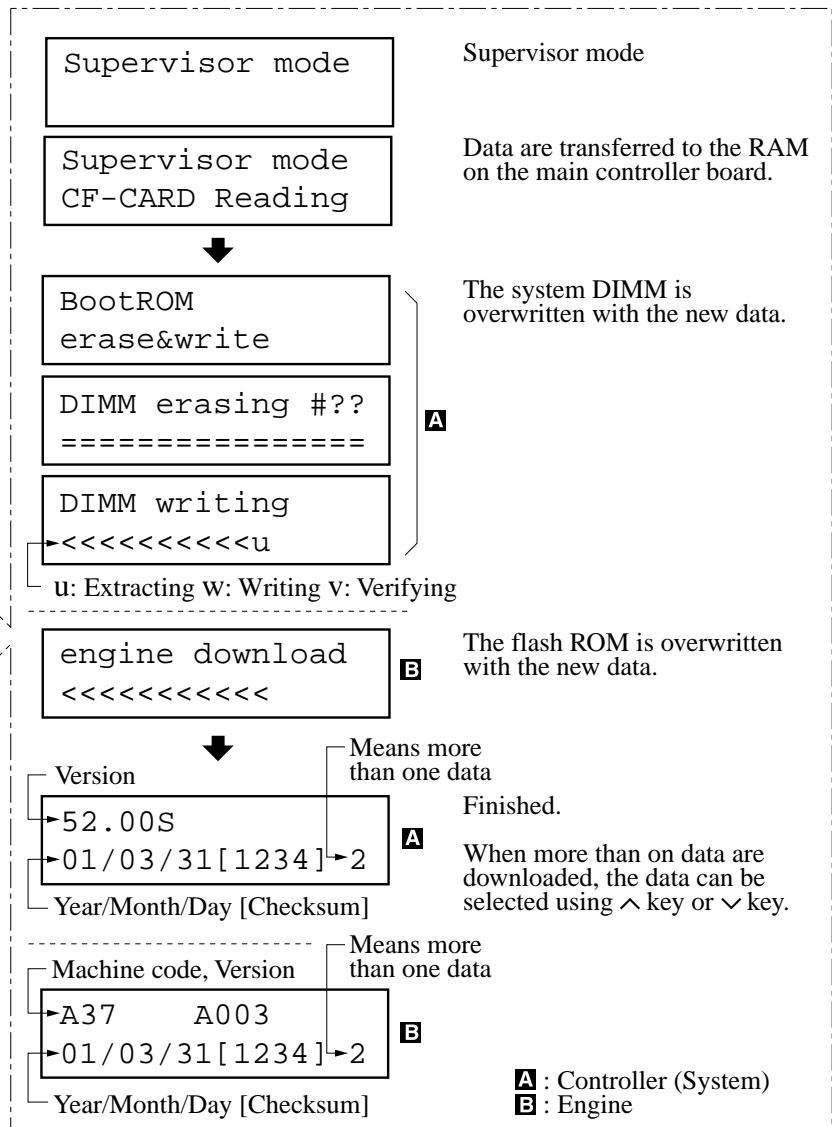

page B-4). If the message display indicates Call service person Dn (n=0, 1, ...), refer to section *Downloading errors* on page 3-20.

(3) Downloading operator panel message data

To download data from the parallel interface, proceed as follows.

CAUTION



Downloading operator panel message data takes several minutes. Do not turn power off during downloading.

Perform in sequence	Display shows
① Turn printer power on.	
② Make sure the printer is Ready.	Ready
③ At the DOS prompt, send the following command to the printer: <pre>>ECHO !R!BOOT'SPR';EXIT;>PRN</pre> Note: Do not add an EXIT; command in the above.	
④ The message display should indicate Supervisor mode.	Supervisor mode parallel waiting
⑤ Copy the message data to the printer by typing: <pre>>COPY\B panel message file. name PRN</pre>	Downloading
⑥ Check the display reverts to Ready.	Ready
⑦ Turn power on again. Check the printer gets Ready.	

If the message display indicates Call service personDn (n=0, 1, ...), refer to section *Downloading error* on next page.

(4) Downloading errors

The following messages are indicated on the message display when an error occurred during downloading the firmware data.

Error message	Meaning	Corrective action
Call service perosonD0	<ul style="list-style-type: none">Checksum error Checksum error occurred during downloading. The flash ROM is empty.	Turn printer power off once, then on again. Try downloading again.
Call service perosonD1	<ul style="list-style-type: none">Machine compatibility error The data to be downloaded is not compatible with the printer.	Obtain correct data for the printer model.
Call service perosonD2	<ul style="list-style-type: none">Version compatibility error The version of the data does not match the current engine version.	Obtain the correct version of data.
Call service perosonD3	<ul style="list-style-type: none">Data error The data to be downloaded is corrupted.	Obtain the correct data.

If the corrective action above does not solve the problem, replace engine board (KP-864). See page 5-22.

Chapter 4 Operation Overview

Chapter 4 Contents

4-1 Electrophotographic system	4-3
4-1-1 Electrophotographic cycle	4-3
(1) Main charging	4-4
Components of drum and main charger unit	4-4
Amorphus-silicon drum	4-5
Charging the drum	4-6
(2) Exposure	4-7
Laser scanner unit	4-8
Drum surface potential	4-10
(3) Development	4-11
(4) Transfer	4-14
(5) Fusing	4-15
Fuser unit mechanism	4-16
(6) Cleaning	4-17
4-2 Paper feeding system	4-18
4-2-1 Paper feed control	4-19
(1) Paper feeding mechanism	4-20
Drive and paper feed unit	4-20
MP tray paper feed unit	4-21
Fuser unit and face up/down output	4-22
4-3 Electrical control system	4-23
4-3-1 Electrical parts layout	4-23
(1) Circuit boards, sensors and switches	4-23
(2) Motors, solenoids, clutches and others	4-24
(3) Drum unit and developer	4-25
4-3-2 Operation of circuit boards	4-26
(1) Main board	4-26
Main board KP-777 for FS-1800/1800N models	4-26
Main board KP-858 for FS-3800/3800N models	4-27
(2) Engine board	4-28
Eraser lamp control circuit	4-29
Toner motor control circuit	4-30
Heater lamp control circuit	4-31
(3) Sensor board	4-33
Paper gauge sensing circuit	4-33
Interlock circuit	4-34
Paper size detecting circuit	4-36
(4) Power supply unit	4-38
(5) High voltage unit	4-39

4-1 Electrophotographic system

Electrophotography is the technology used in laser printing which transfer data representing texts and graphics objects into a visible image which is developed on the photosensitive drum, finally fusing them on paper using the light beam generated by a laser diode.

This section provides technical details on the printer’s electrophotography system.

4-1-1 Electrophotographic cycle

The electrophotographic system of the printer performs a cyclic action made of six steps as follows. Each step is technically explained in the following sections.

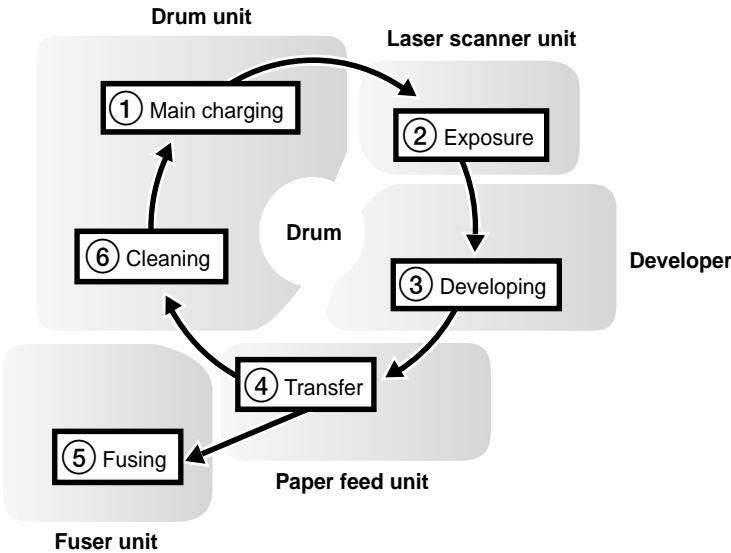

Figure 4-1-1 Electrophotographic cycle

(1) Main charging
Components of drum and main charger unit

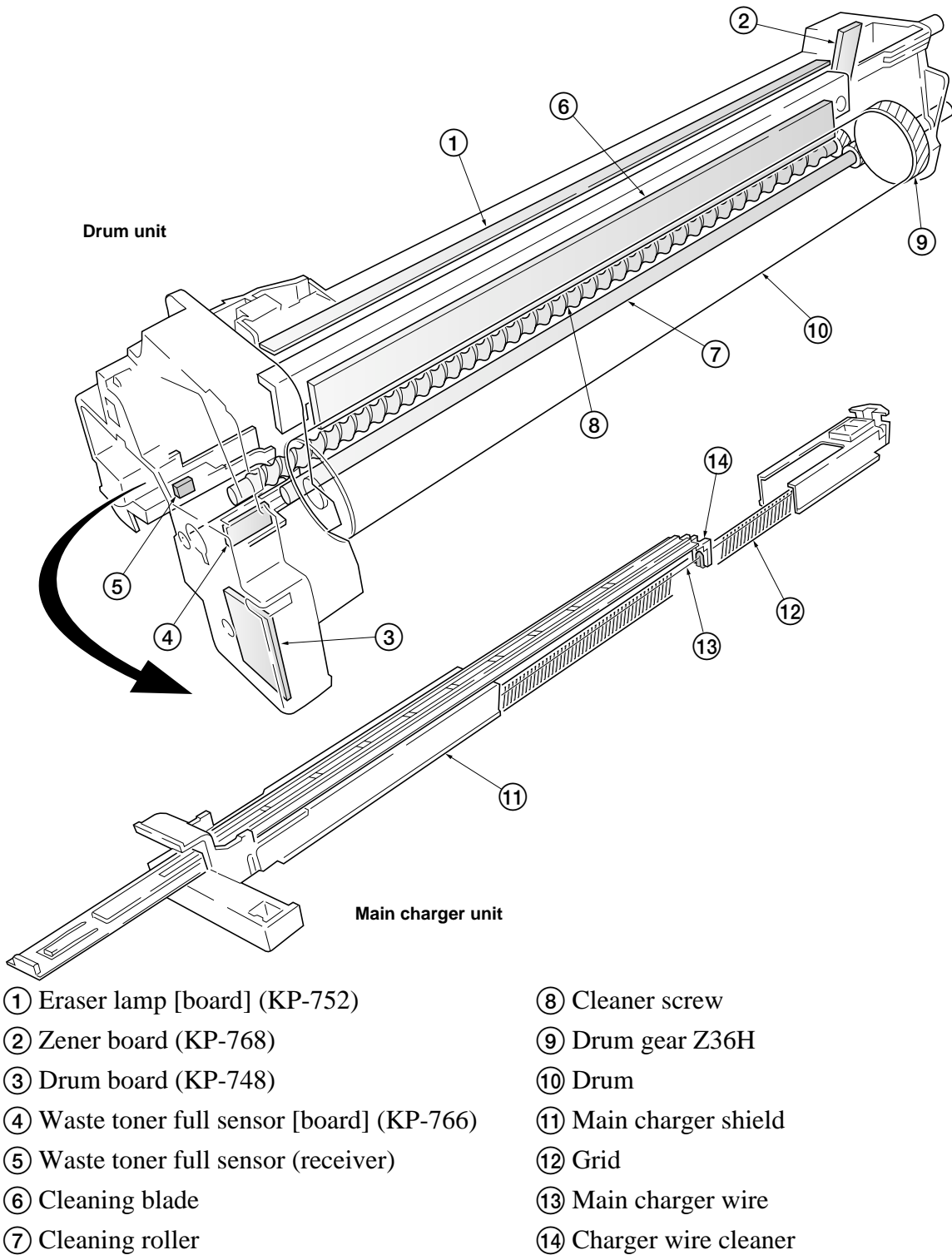
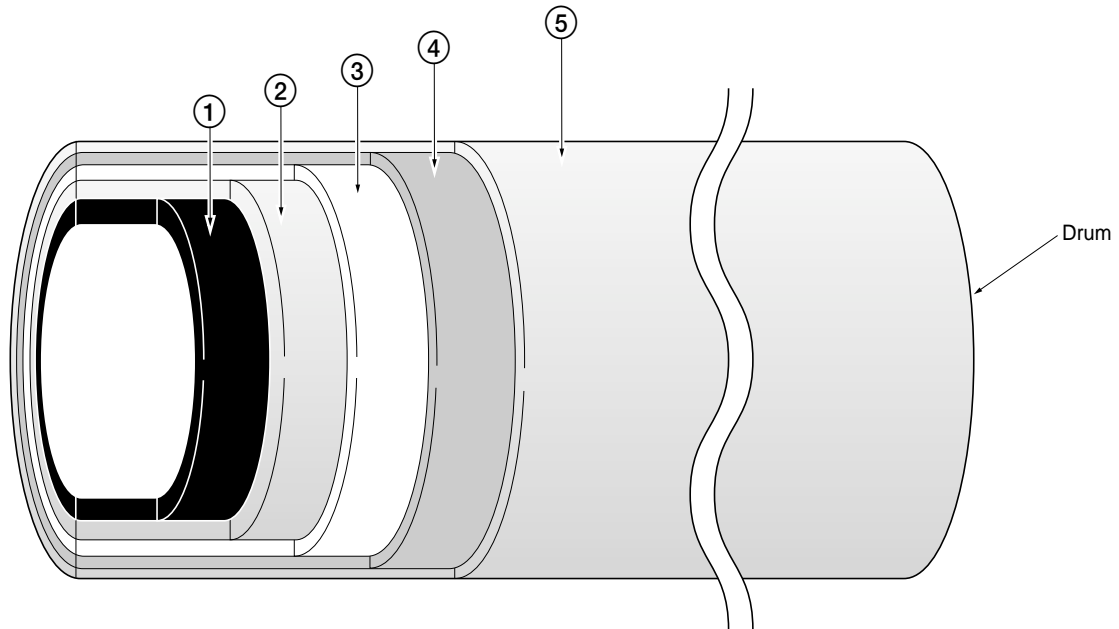

Figure 4-1-2 Components of drum and main charger unit

Amorphous-silicon drum

The printer use the long lasting amorphous silicon drum. The drum surface is a composite of five substances coated in five layers as shown below.



- ① Aluminum base
- ② Carrier block (1 to 3 μm thick)
- ③ Photoconductor a-Si
- ④ Primary protection layer (1 μm thick)
- ⑤ Secondary protection layer

Figure 4-1-3 Amorphous silicon drum

The primary and secondary layers are for protecting the amorphous silicon layer underneath. The amorphous silicon layer is of photoconductive, meaning it can be electronically conductive when exposed to a (laser) light source to effectively ground electrons charged on its outer surface to the ground. This layer is approximately 9 μm thick.

The carrier block layer lies between the amorphous silicon layer and the aluminum base cylinder and prevents the backward electron flow, from the base cylinder to the drum's outer surface, which might give adverse effect (possibly "ghost") on the print quality.

Charging the drum

The following shows a simplified diagram of the electrophotographic components in relation to the engine system. Charging the drum (A) is done by the main charger wire (B).

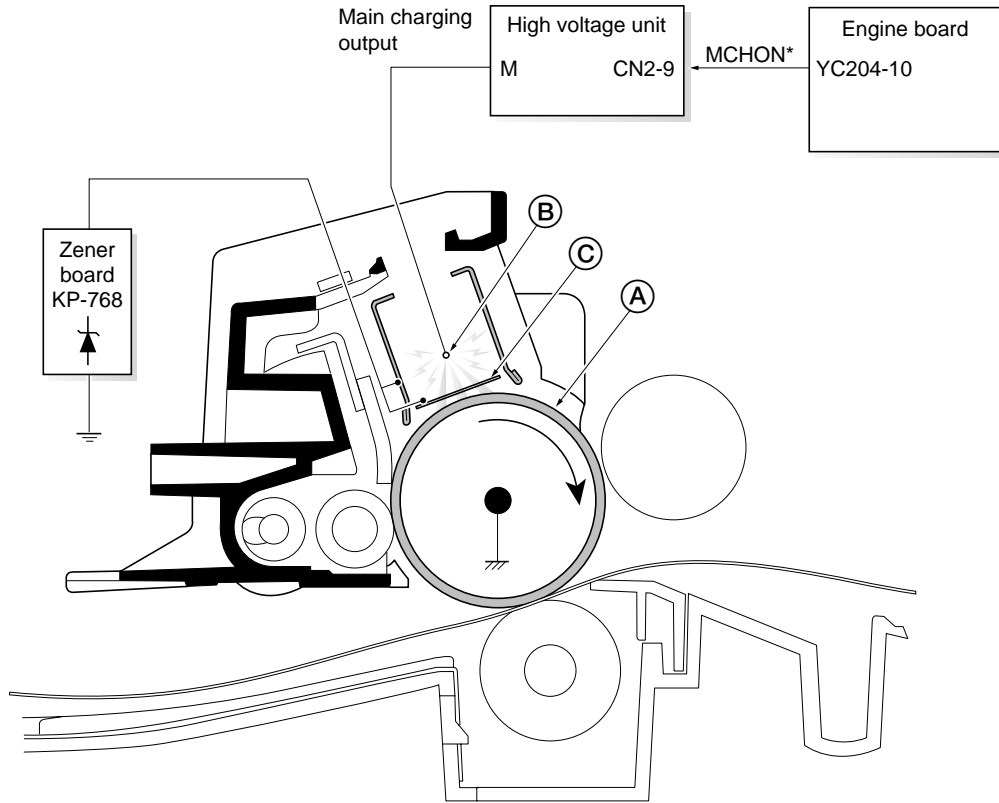

Figure 4-1-4 Charging the drum

As the drum (A) rotates in a “clean (neutral)” state, its photoconductive layer is given a uniform, positive (+) corona charge dispersed by the main charger wire (B). The grid (C) regulates the main charging potential so that it is evenly and stably dispersed over the drum (A) at a constant voltage level.

Due to being high-voltage scorotron charging, the main charger wire (B) can get contaminated by oxidization after a long run. Therefore, it must be cleaned periodically from time to time using the method explained in chapter 3, page 3-9. Cleaning the main charger wire (B) prevents print quality problems such as black streaks.

(2) Exposure

The charged surface of the drum (A) is exposed to the laser beam scanning from the laser scanner unit (B).

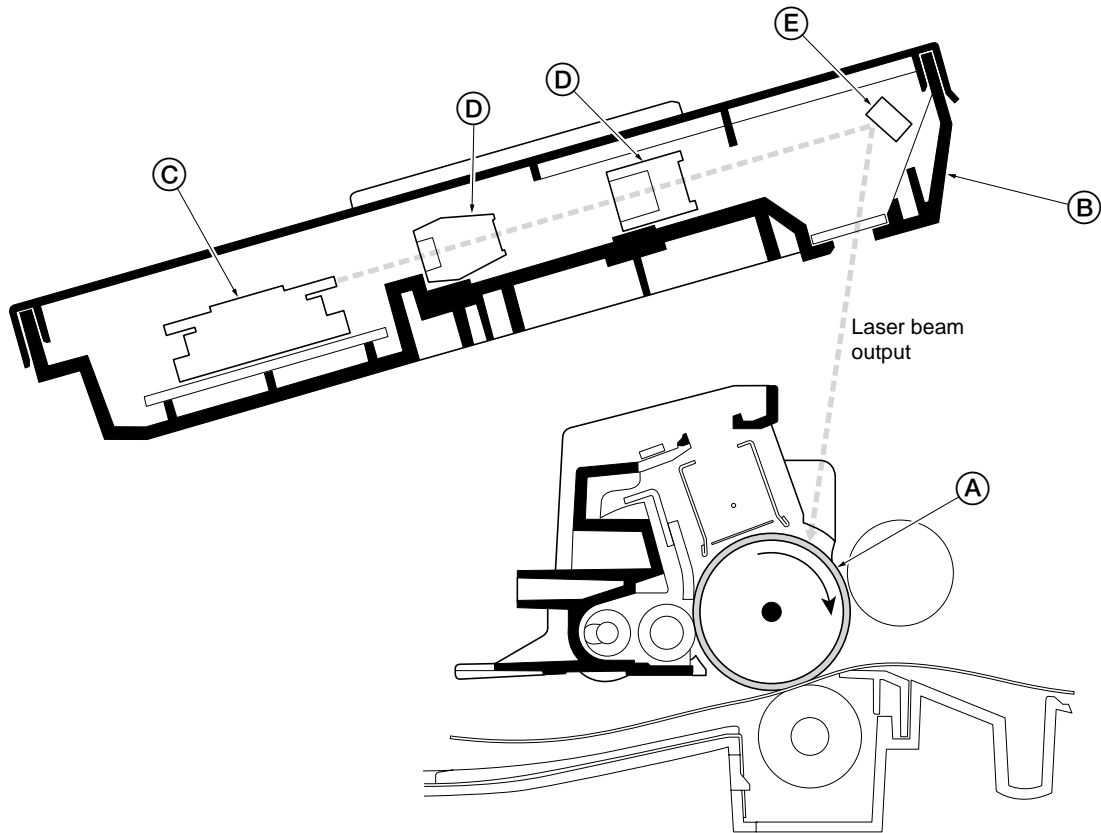

Figure 4-1-5 Exposure

The polygon motor (C) (with polygon mirrors) revolves to reflect the laser beam over the drum (A). Lenses (D) and diversion mirror (E) are housed in the laser scanner unit (B). These lenses adjust the diameter of the laser beam (670 nm wavelength) so that the laser beam effectively focalizes on the drum (A) surface.

Laser scanner unit

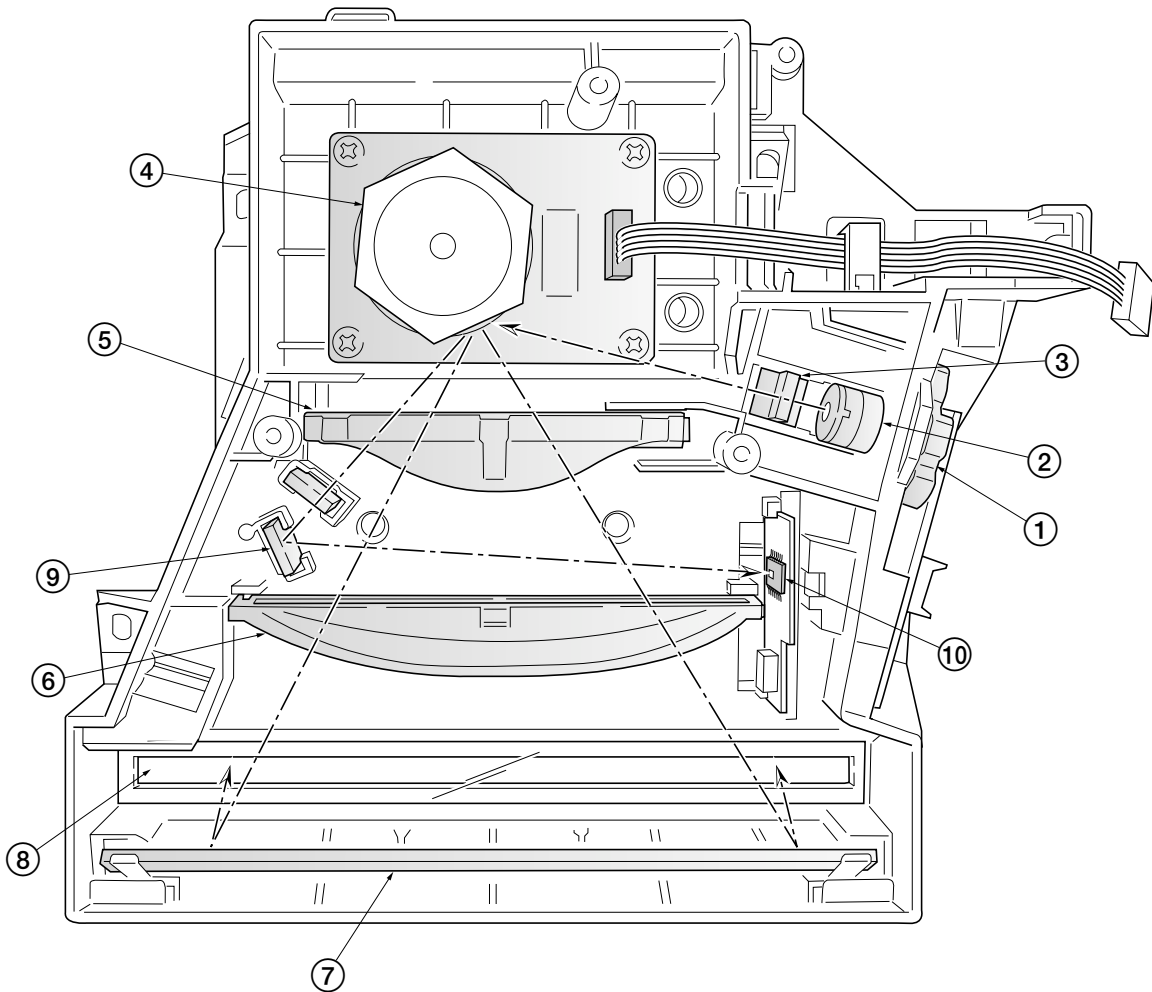

Figure 4-1-6 Laser scanner unit

Name	Description
① Laser diode	Emits diffused, visible laser.
② Collimator lens	Aligns the laser beam to the cylindrical lens.
③ Cylindrical lens	Compensates the vertical angle at which the laser beam hits on of the polygon mirror segments.
④ Polygon motor	Has six mirror segments around its hexagonal circumference. Each mirror corresponds to one scanned line width on the drum when the laser beam scans on it.

Name	Description
⑤ Primary f-theta lens	See figure 4-1-7 below.
⑥ Secondary f-theta lens	The primary (above) and secondary f-theta lenses equalize focusing distortion on the area on the drum closer to the edge. The effective length of line (A), (B) in the figure below) the laser beam draws on the drum becomes longer as the laser beam hits closer to the drum edge. In the figure 4-1-7 below, distances represented by (A) and (B) are not the same ($A > B$) until the f-theta lenses are provided between the polygon mirror and the drum ($A = B$).
⑦ Diversion mirror	Diverts the laser beam vertically onto the drum. Note the diffused laser beam finally pinpoints on the drum.
⑧ Protective glass	Prevent dust, debris, etc., from entering the scanner assembly.
⑨ Sensor mirror	Bends the very first shot of a laser scan towards the pin photo sensor (below).
⑩ Pin photo sensor	When shone by the sensor mirror above, this pin photo sensor generates a trigger signal.

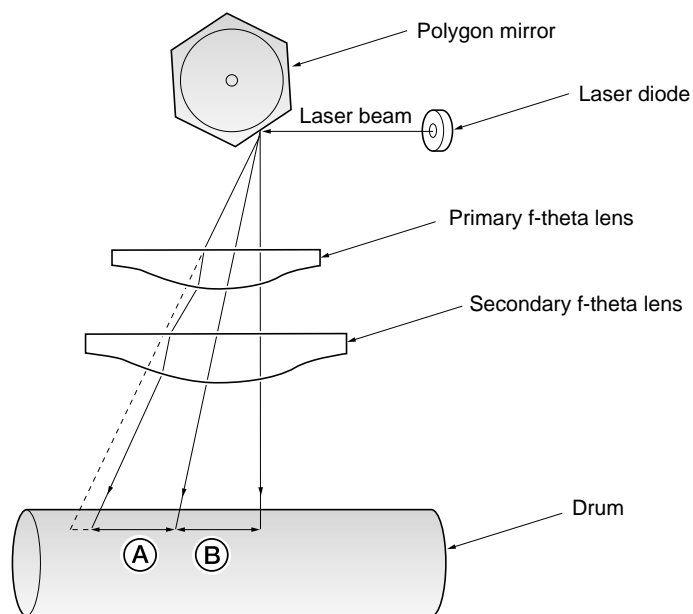

Figure 4-1-7 F-theta lens

Drum surface potential

The laser beam is continually switched on and off depending on the print data. It is on for a black (exposed) dot and off for a white (blank) dot. Since the drum surface is evenly charged, whenever it is illuminated by the laser beam, the electrical resistance of the photoconductor is reduced and the potential on the photoconductor is also lowered. Resulted on the drum surface is an electrostatic image which represents the data to print. Note that the area to be printed black has the low potential, constituting a “positively exposed” image.

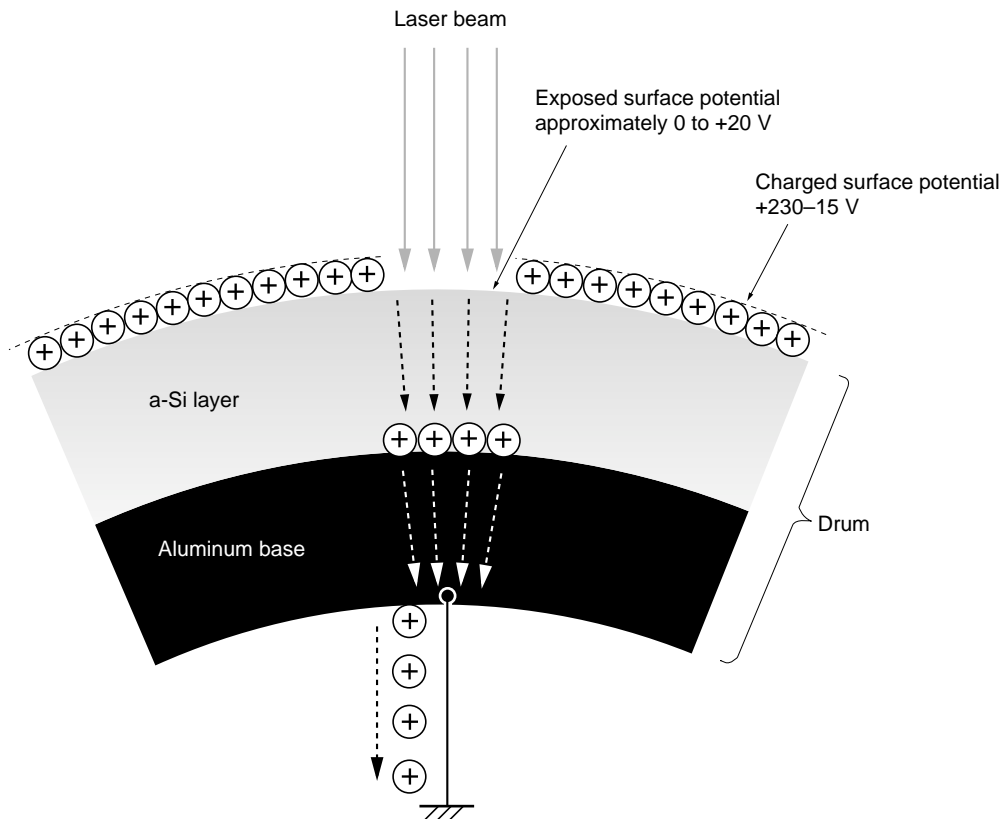

Figure 4-1-8 Drum surface potential

(3) Development

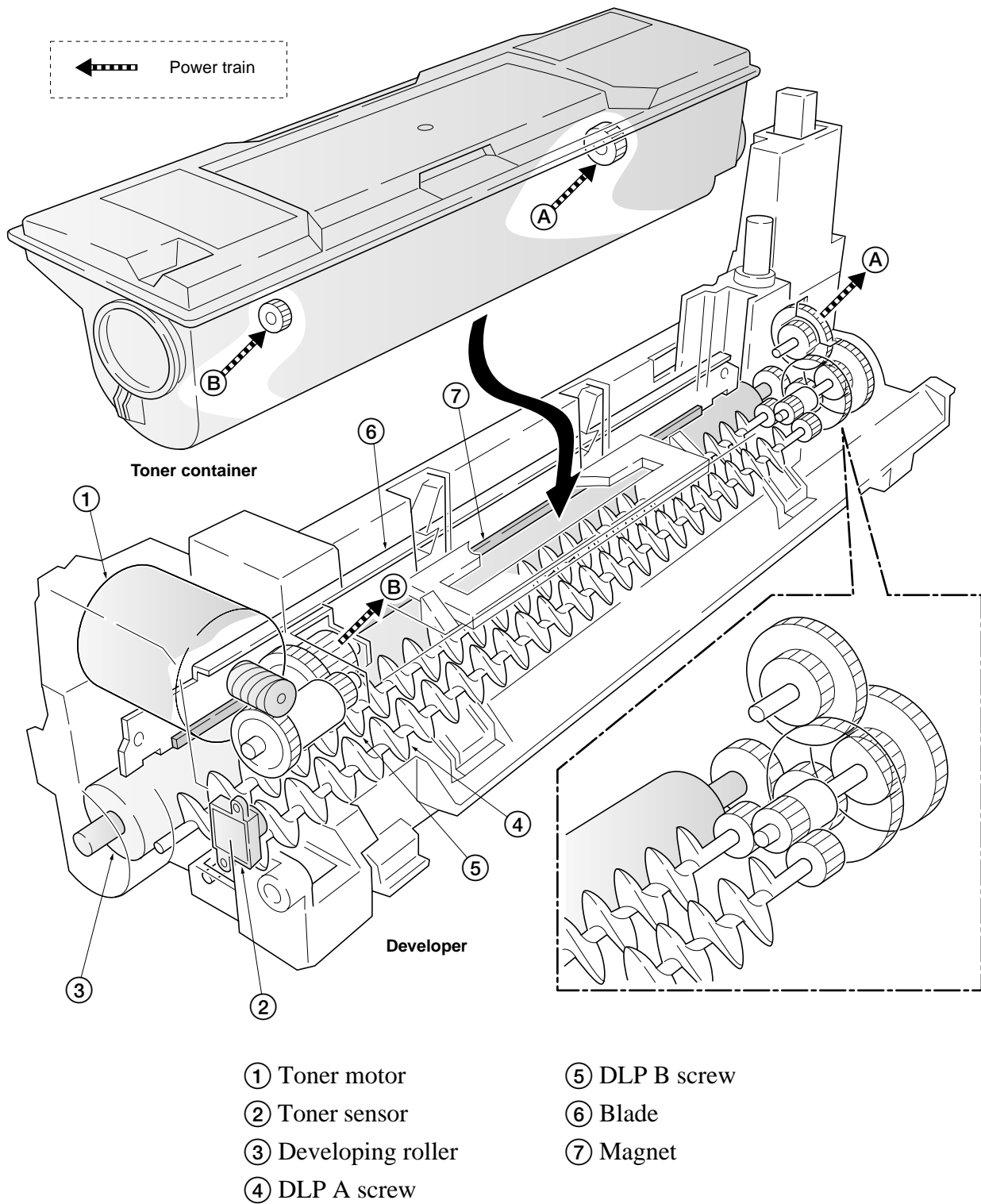

Figure 4-1-9 Developer mechanism

The latent image constituted on the drum (A) is developed into a visible image. The developing roller (B) contains a 4-pole (S-N-S-N) magnet core (C) and an aluminum cylinder rotating around the magnet core (C). Toner attracts to the developing roller (B) since it is powdery ink made of black resin bound to iron particles. Blade (D) magnetized by magnet (E) is positioned approximately 0.3 to 0.4 mm above the developing roller (B). It constitutes a smooth layer of toner in accordance with the revolution of the roller.

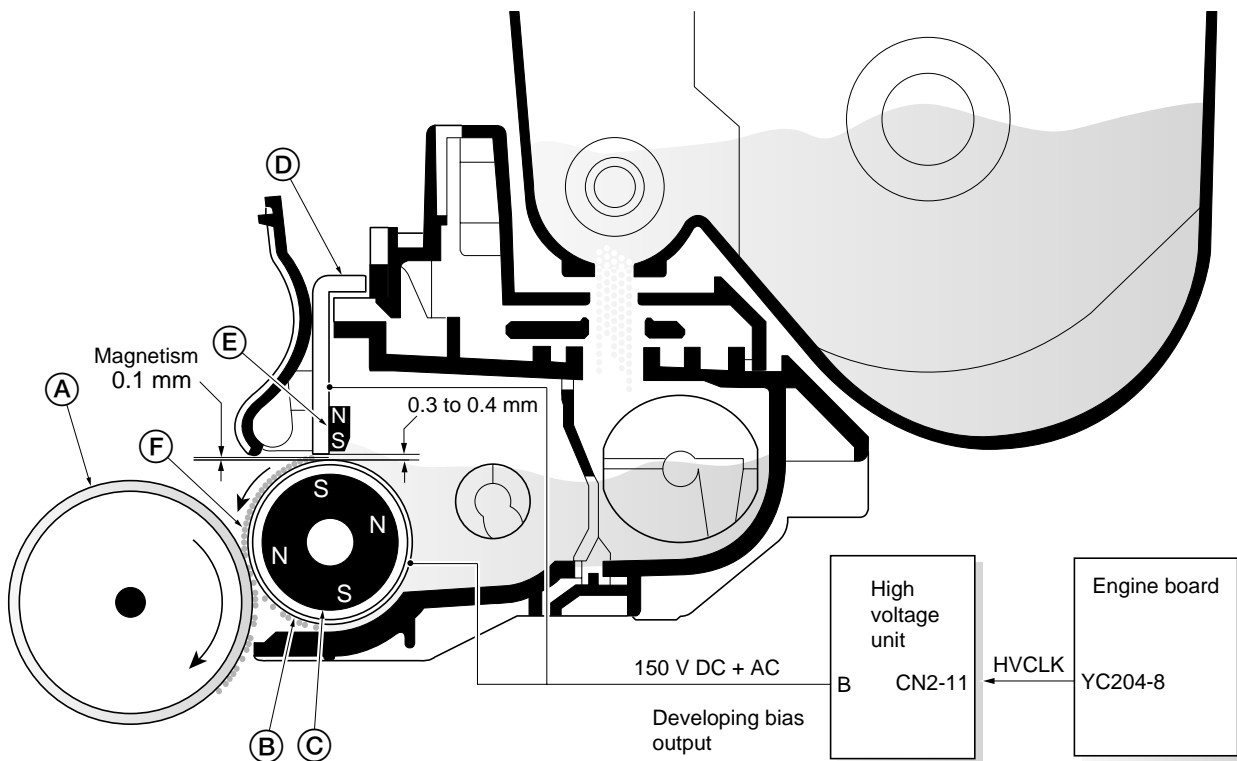

Figure 4-1-10 Development

The developing roller (B) is applied with the AC-weighted, positive DC power source. Toner (F) on the developing roller (B) is given a positive charge. The positively charged toner (F) is then attracted to the areas of the drum (A) which was exposed to the laser light. (The gap between the drum (A) and the developing roller (B) is approximately 0.3 mm.) The non-exposed areas of the drum (A) repel the positively charged toner as these areas maintain the positive charge. The developing roller (B) is also AC-biased to ensure contrast in yielding by compensating the toner's attraction and repelling action during development.

A toner sensor is provided within the developer. As the toner supply from the toner container dwindles and the toner level lowers in the reservoir, the sensor translates it into an electrical signal through its diaphragm, urging the toner motor to feed more toner.

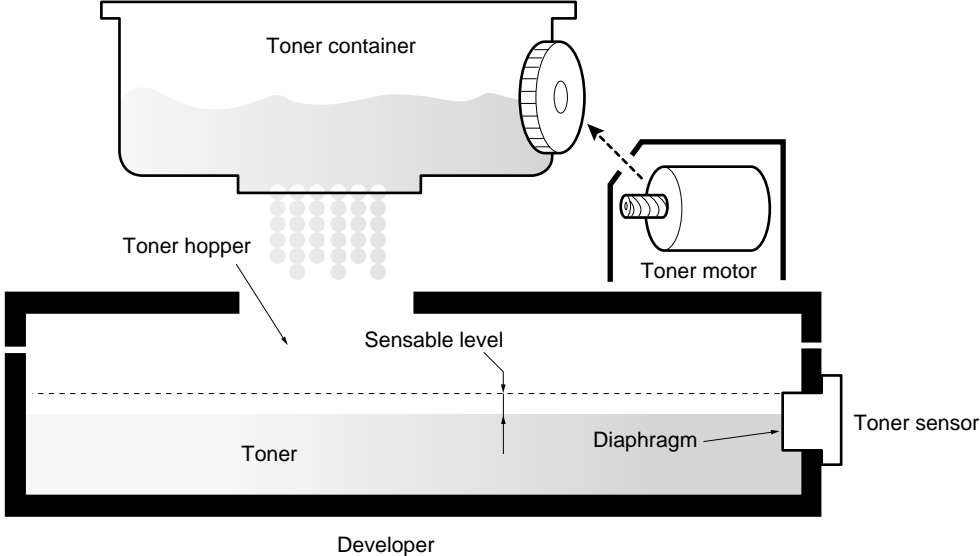

Figure 4-1-11 Toner sensor

(4) Transfer

The image developed by toner on the drum (A) is transferred onto the paper because of the electrical attraction between the toner itself and the transfer roller (B). The transfer roller (B) is negatively-biased so that the positively-charged toner is attracted onto the paper while it is pinched by the drum (A) and the transfer roller (B).

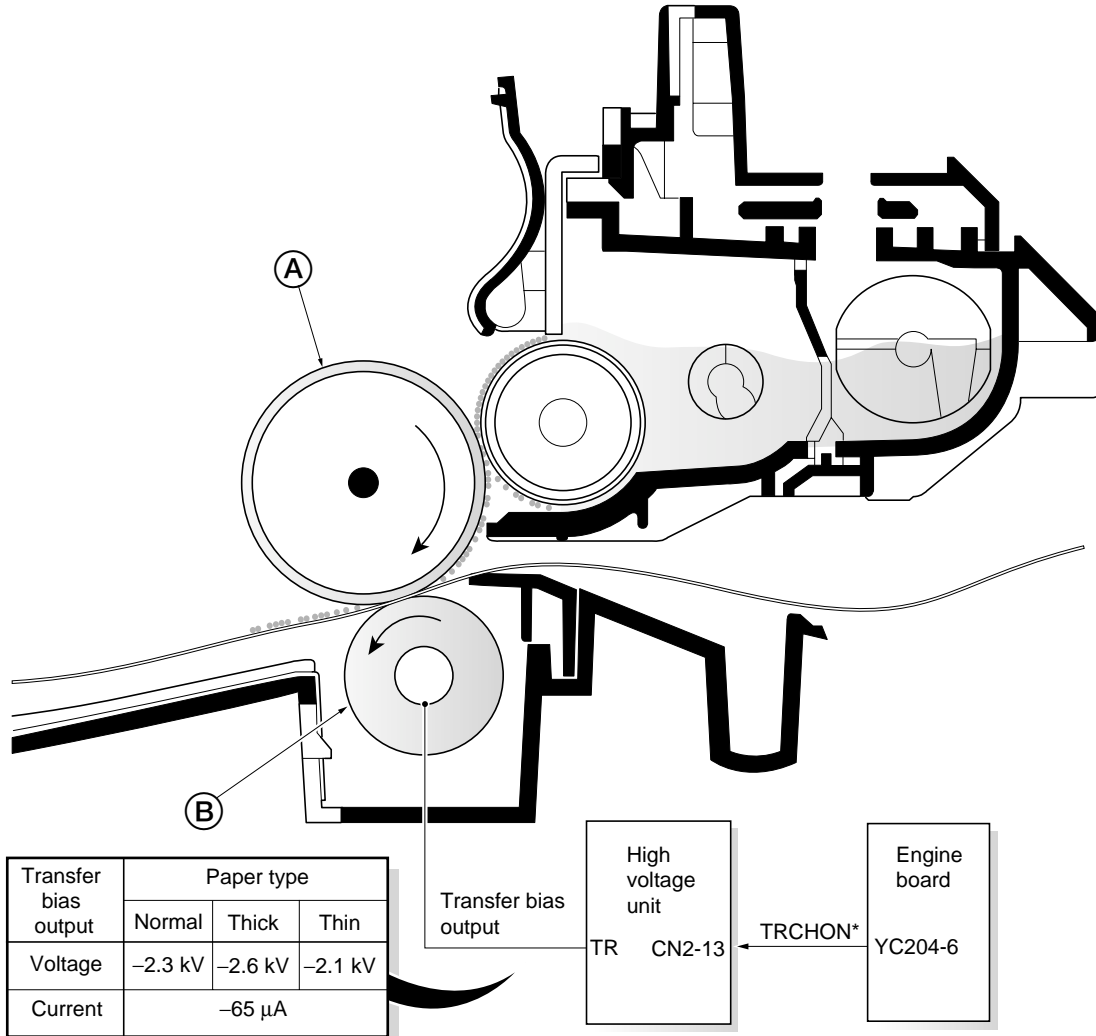

Figure 4-1-12 Transfer

The nominal transfer bias is set to approximately -2.3 kV (limit) with the -65 μ A current. Since the ideal potential of the transfer bias depends on the thickness of paper, the bias is raised to approximately -2.6 kV/-65 μ A for thicker paper. On the other hand, the bias current is reduced to -2.1 kV/-65 μ A for thin paper.

(5) Fusing

The toner on the paper is molten by heat and pressed into the paper as it passes between the heat roller (A) and the press roller (B) in the fuser unit.

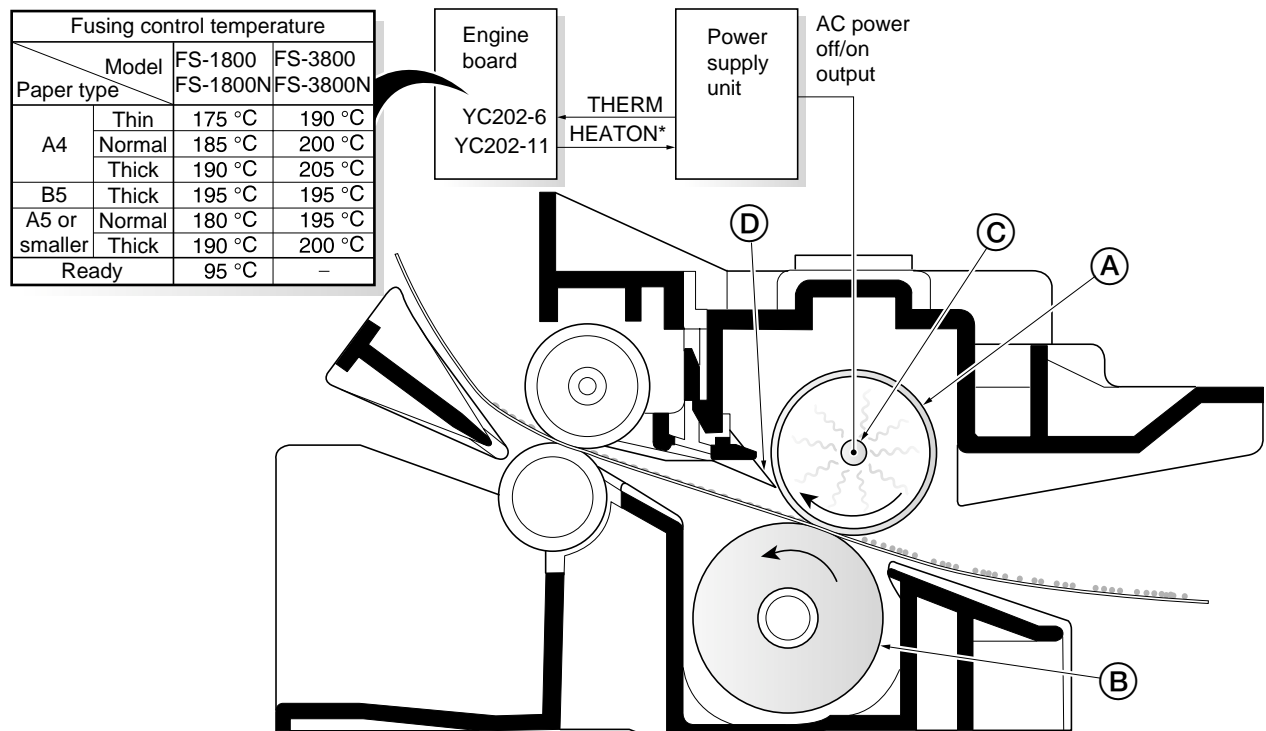

Figure 4-1-13 Fusing

The heat roller (A) has a heater (infrared) lamp (C) inside which continuously turns on and off by the thermistor to maintain the constant temperature on the heat roller (A) surface. The fusing temperature is also controlled based on paper types. See the table in the figure above.

The heat roller (A) is fluorine coated by to prevent toner from accumulating on the roller after a long usage. Care must be taken while handling the heat roller (A) not to scratch the roller surface as doing so may result in quality problems.

The heat roller (A) has four scraping claws (Separators) (D) which are continuously in contact with its surface. These claws prevent the paper on which toner has been fused from being wound around the heat roller (A) causing paper jam.

The press roller (B) is made of the heat resistant silicon rubber. This roller is used to strongly press the paper towards the heat roller (A) by means of coil springs.

The temperature of the heat roller (A) is constantly monitored by the engine board using the thermistor and triac. Should the temperature of the heat roller (A) exceed the predetermined value, the thermal cutout is activated to effectively disconnect the heater lamp (C) from power.

Fuser unit mechanism

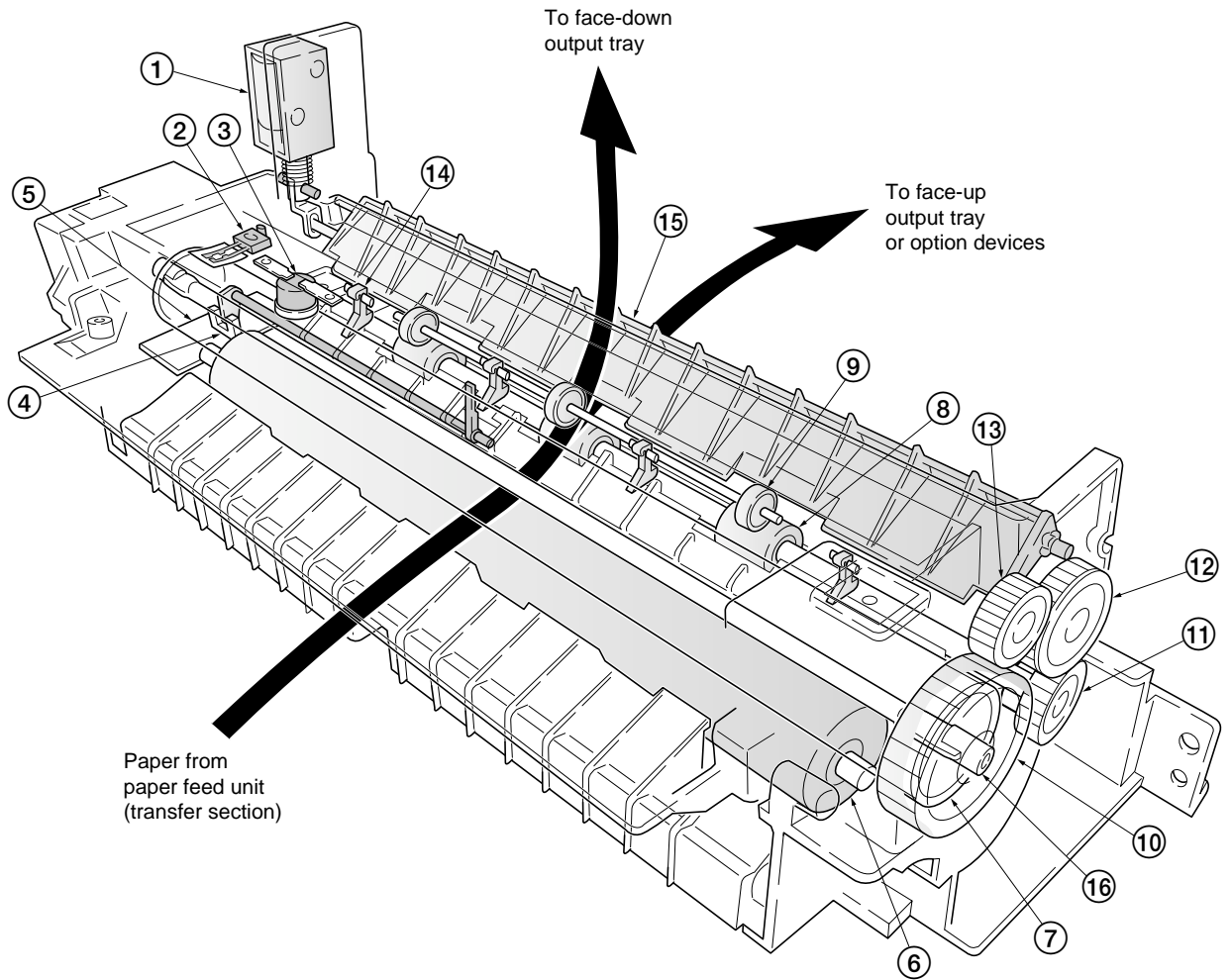

- | | | |
|-------------------------|--------------------------------------------------|--------------------------------------------------|
| ① Face up/down solenoid | ⑦ Heat roller | ⑬ Idle gear Z28 ^{*1} /Z21 ^{*2} |
| ② Thermistor | ⑧ Exit roller | ⑭ Separator(s) |
| ③ Thermal cutout | ⑨ Exit pulley(s) | ⑮ Change guide |
| ④ Exit sensor | ⑩ Heat gear Z36 ^{*1} /Z46 ^{*2} | ⑯ Heater lamp |
| ⑤ Fuser board (KP-756) | ⑪ Exit gear Z21 | |
| ⑥ Press roller | ⑫ Idle gear Z18 ^{*1} /Z28 ^{*2} | *1: FS-1800/1800N *2: FS-3800/3800N |

Figure 4-1-14 Fuser unit mechanism

(6) Cleaning

After the transferring process, the drum needs to be physically cleaned of toner which is residual after the development process. The cleaning blade (A) is constantly pressed against the drum (B) and scrapes the residual toner on the drum off to the cleaning roller (C). The cleaning roller drives the toner to the cleaner screw (D) at one end of which the waste toner bottle is connected to collect the waste toner.

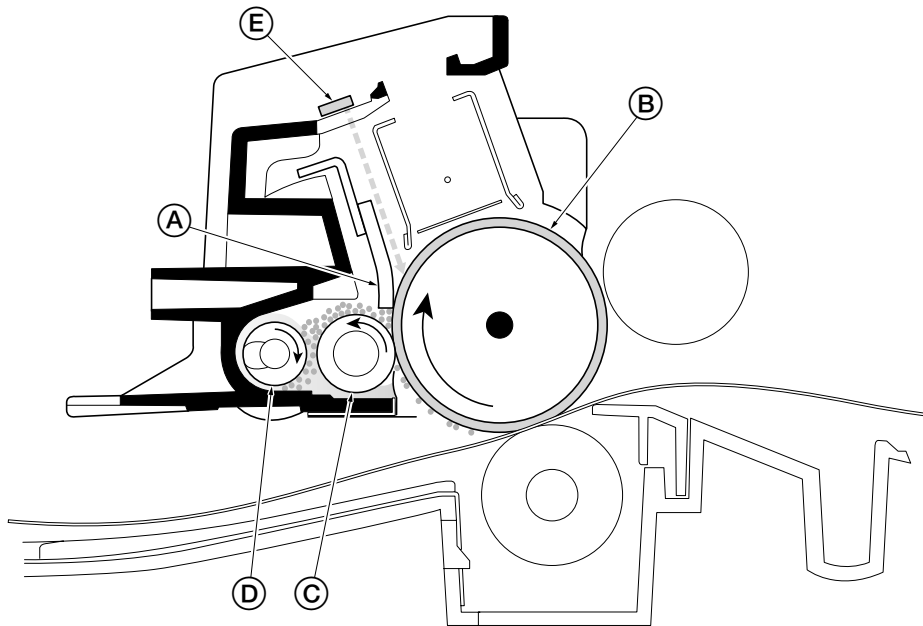

Figure 4-1-15 Drum cleaning and erasing static charge

After the drum (A) is physically cleaned, it then must be electrically cleaned to neutral state. This is necessary to erase any residual positive charges, ready to accept the next uniform charge. The residual charge is canceled by exposing the drum (A) to the light emitted from the eraser lamp [board] (E) (See figure 4-1-15 above.) in the similar manner as described on page 4-6. This lowers the electrical conductivity of the drum (A) surface making the residual charge on the drum (A) surface escape to the ground.

4-2 Paper feeding system

The paper feeding system picks up paper from the paper cassette, MP tray, or if installed, the paper feeder PF-60, feeds it in the printer and delivers in the output tray. Paper is feed at the precise timing in synchronization with data processing. The paper feeding system finally delivers the printed page to either the face-down or face-up output tray as manipulated by the user.

The figure below shows the components in the paper feeding system and the paths through which the paper travels. The sensors, clutches, solenoids, motor etc., are described in the following pages.

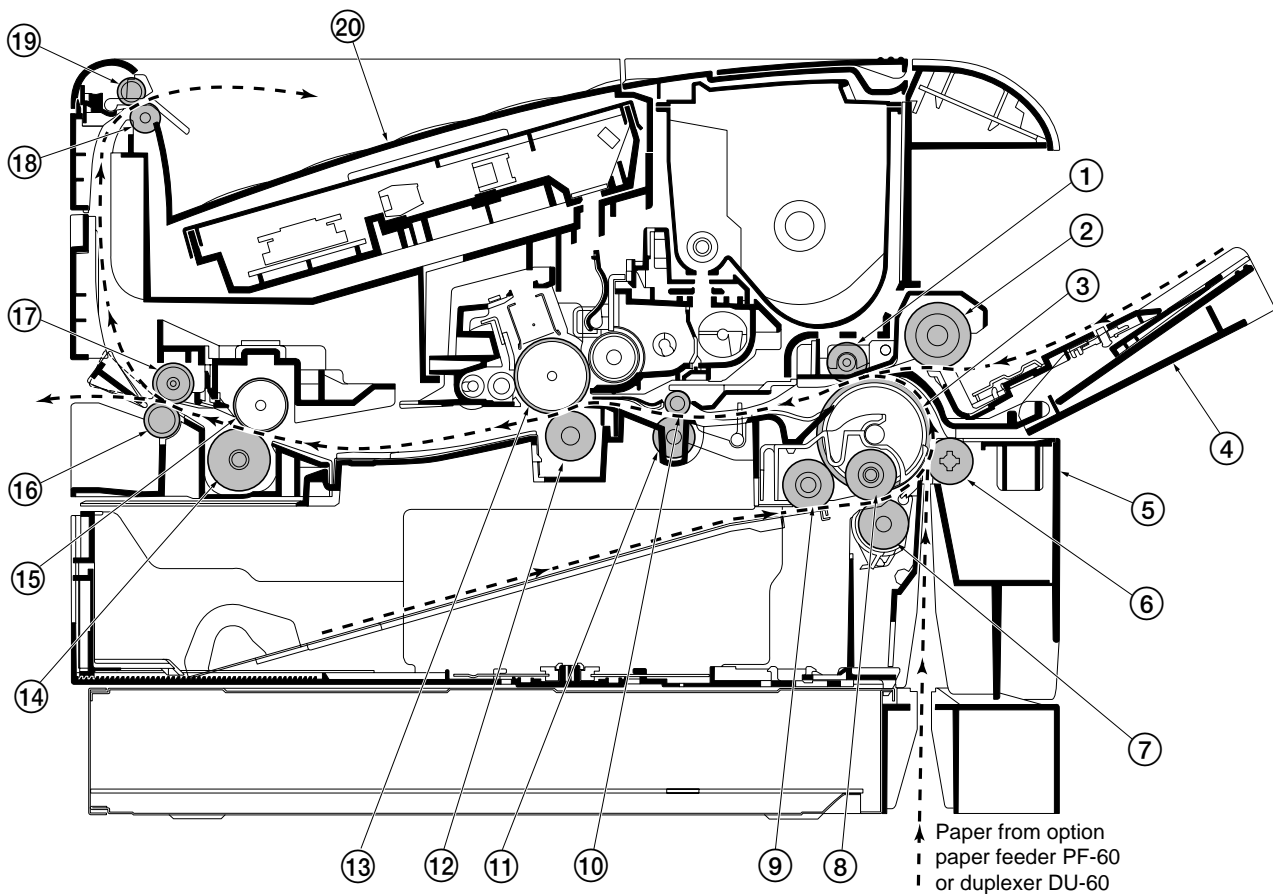

- | | | |
|-----------------------|-----------------------------|-------------------------|
| ① Middle feed roller | ⑧ Feed roller | ⑮ Heat roller |
| ② MP tray feed roller | ⑨ Pickup roller | ⑯ Exit roller |
| ③ Guide pulley(s) | ⑩ Upper registration roller | ⑰ Exit pulley(s) |
| ④ MP tray | ⑪ Lower registration roller | ⑱ FD roller |
| ⑤ Paper cassette | ⑫ Transfer roller | ⑲ Pinch roller(s) |
| ⑥ Feed pulley | ⑬ Drum | ⑳ Face-down output tray |
| ⑦ Retard roller | ⑭ Press roller | |

Figure 4-2-1 Paper feeding components

4-2-1 Paper feed control

The following diagram shows interconnectivity of the feeding system components including the sensors and rollers. The engine board issues various signals in synchronization with the electrophotographic process that is executed by the main board.

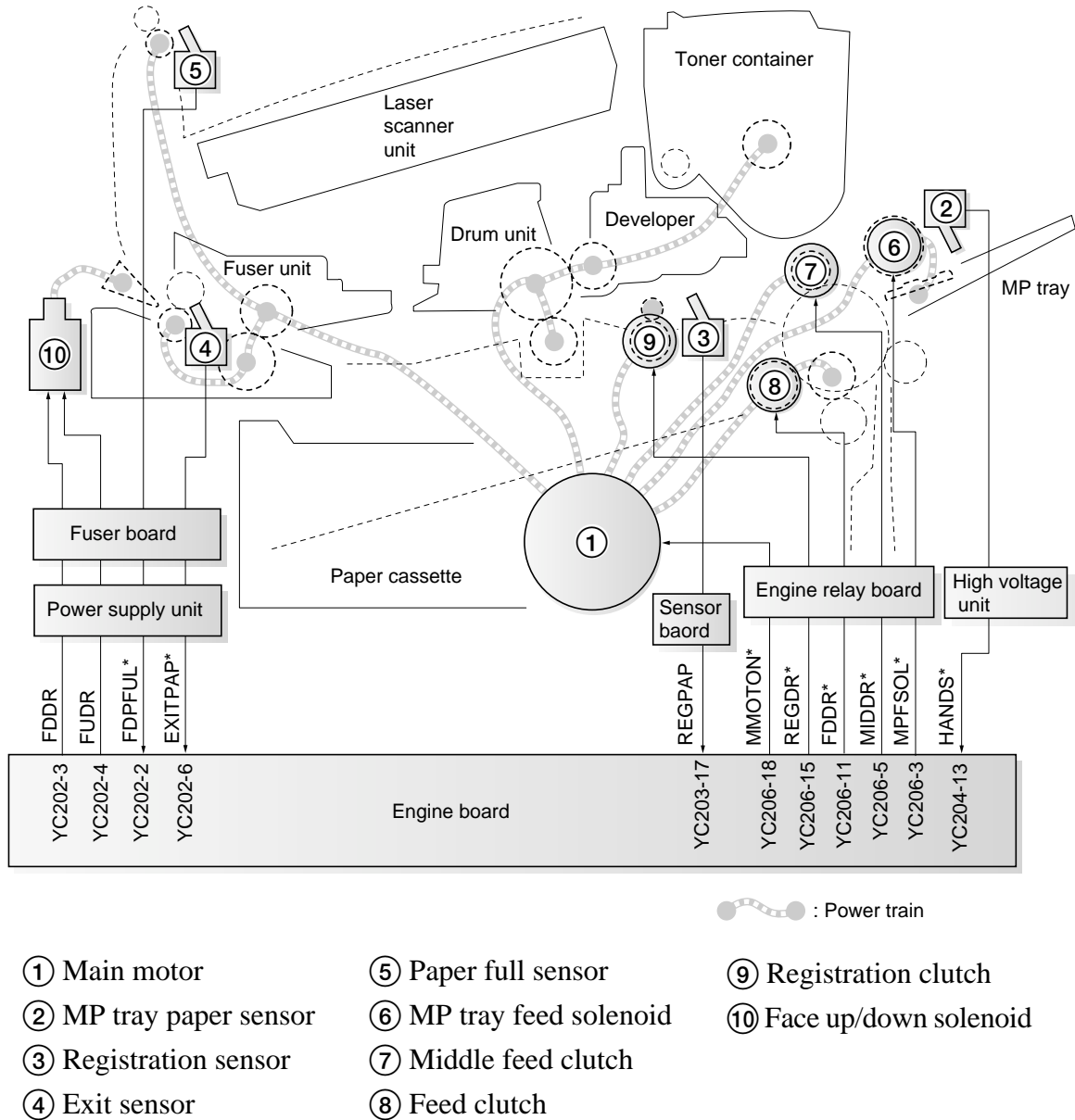
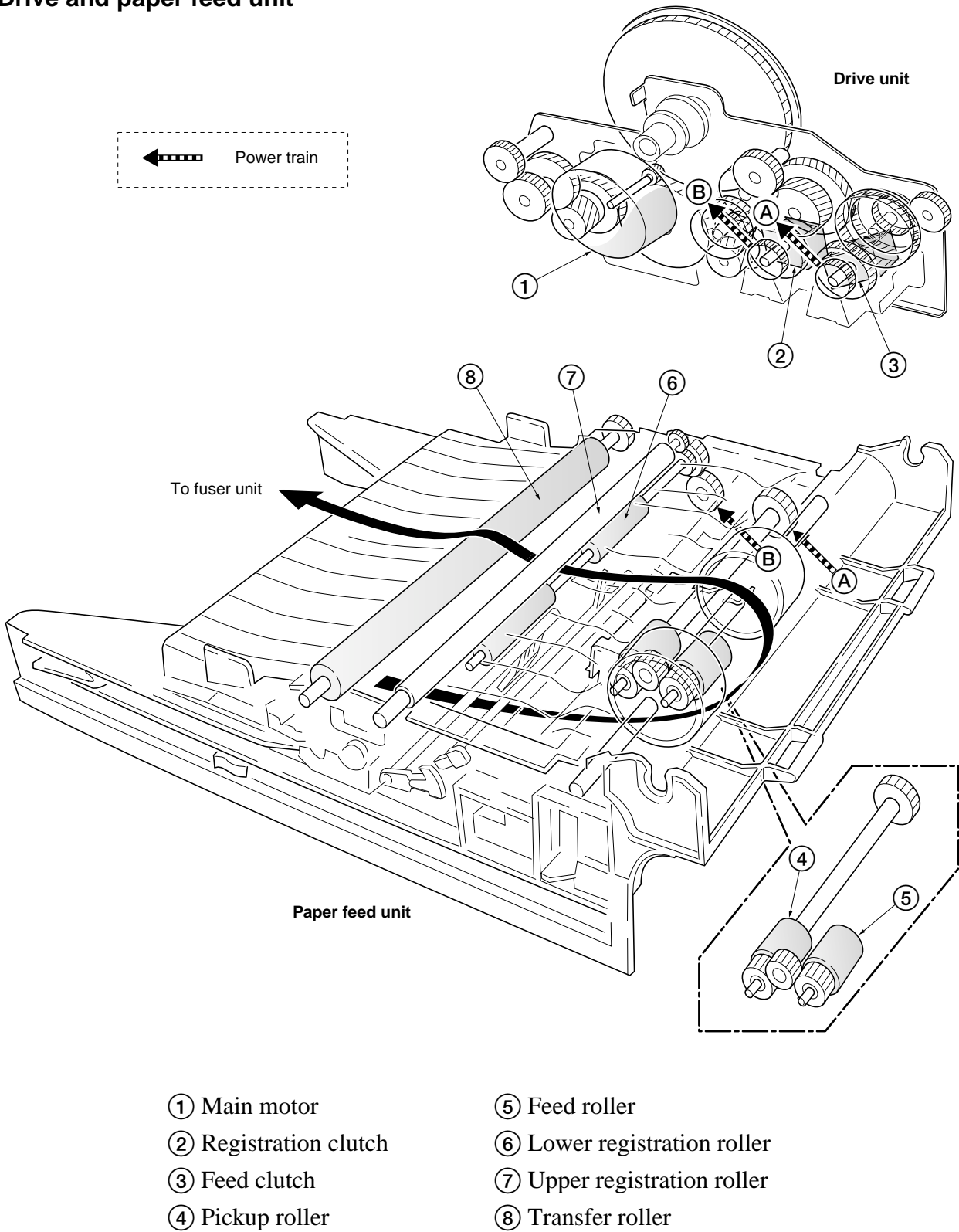

Figure 4-2-2 Paper feed control

(1) Paper feeding mechanism
Drive and paper feed unit



- | | |
|-----------------------|-----------------------------|
| ① Main motor | ⑤ Feed roller |
| ② Registration clutch | ⑥ Lower registration roller |
| ③ Feed clutch | ⑦ Upper registration roller |
| ④ Pickup roller | ⑧ Transfer roller |

Figure 4-2-3 Drive and paper feed unit

MP tray paper feed unit

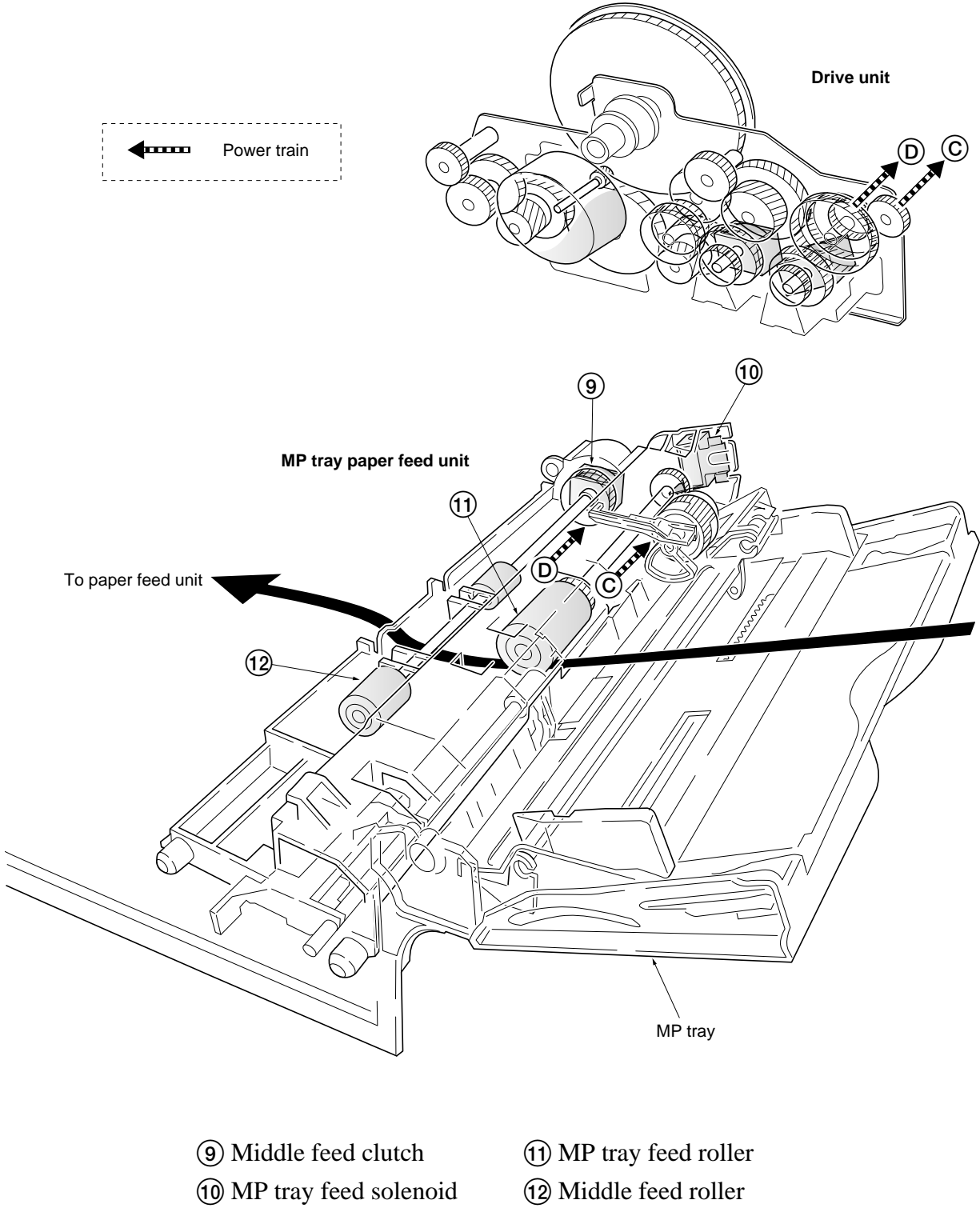

- ⑨ Middle feed clutch
- ⑩ MP tray feed solenoid
- ⑪ MP tray feed roller
- ⑫ Middle feed roller

Figure 4-2-4 MP tray paper feed unit

Fuser unit and face up/down output

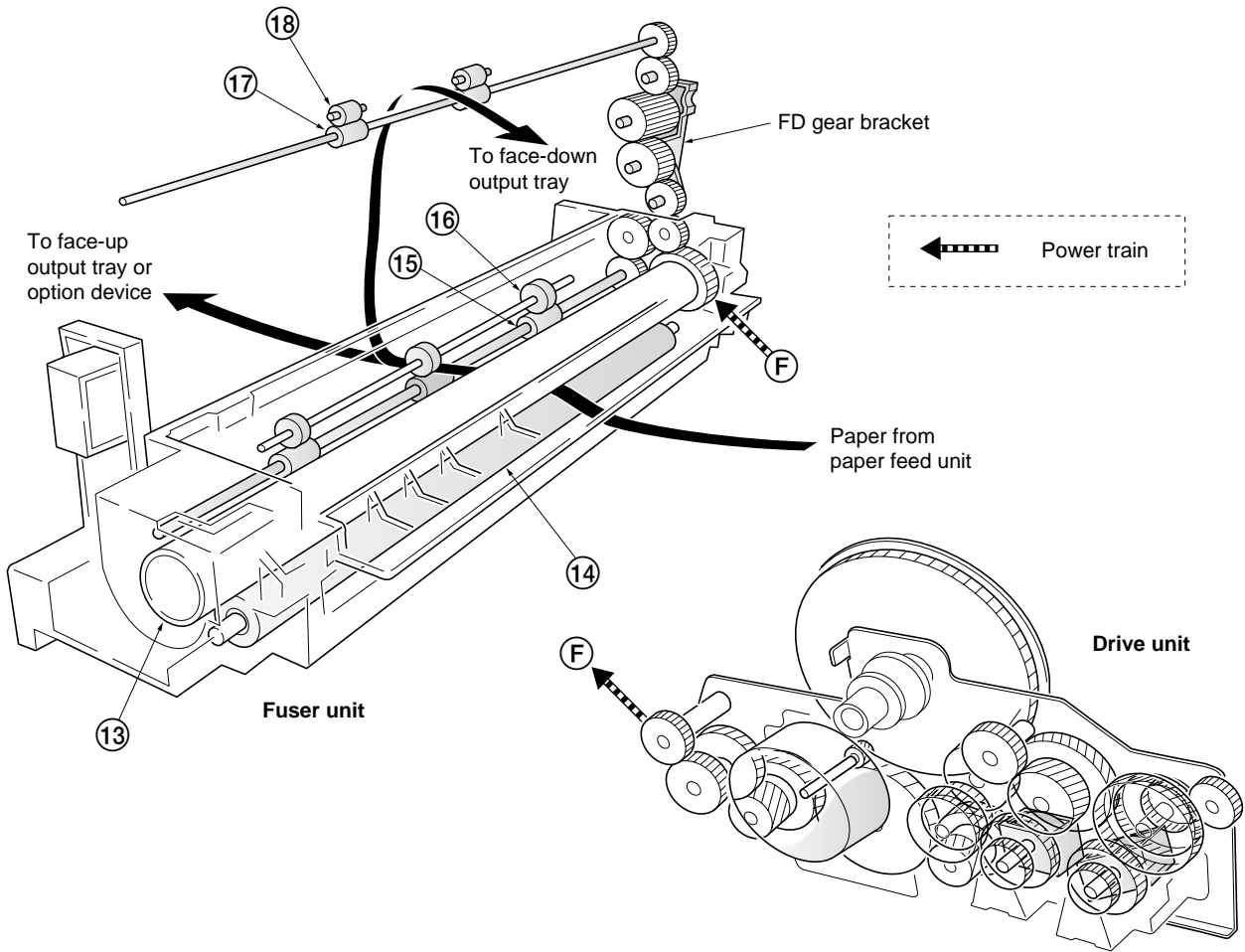

- | | | |
|----------------|------------------|-------------------|
| ⑬ Heat roller | ⑮ Exit roller | ⑰ FD roller |
| ⑭ Press roller | ⑯ Exit pulley(s) | ⑱ Pinch roller(s) |

Figure 4-2-5 Fuser unit and face up/down output

4-3 Electrical control system

4-3-1 Electrical parts layout

(1) Circuit boards, sensors and switches

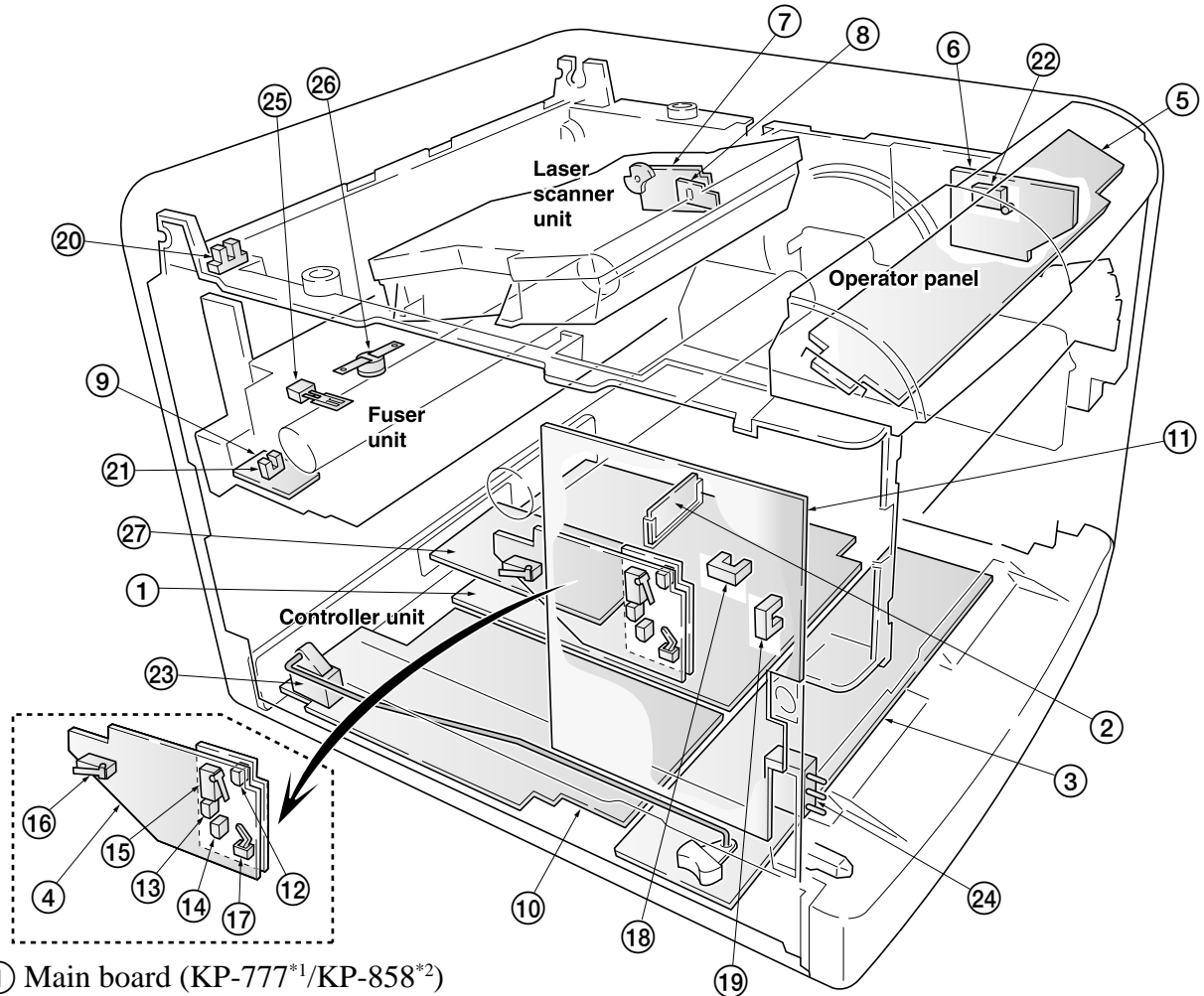

- ① Main board (KP-777*¹/KP-858*²)
- ② System DIMM [board] (KP-710*¹/KP-689*²)
- ③ Engine board (KP-864)
- ④ Sensor board (KP-574)
- ⑤ LCD controller board (KP-738)
- ⑥ Engine relay board (KP-760)
- ⑦ APC board (KP-742)
- ⑧ Pin photo diode sensor [board] (KP-746)
- ⑨ Fuser board (KP-756)
- ⑩ Power supply unit
- ⑪ High voltage unit
- ⑫ Registration sensor (PH701)
- ⑬ Paper gauge sensor 1 (PH702)
- ⑭ Paper gauge sensor 2 (PH703)
- ⑮ Top cover/paper feed unit interlock switch (SW702)
- ⑯ Side cover interlock switch (SW703)
- ⑰ Top cover switch (SW701)
- ⑱ MP tray paper sensor (PC502)
- ⑲ Option feeder sensor (PC501)
- ⑳ Paper full sensor
- ㉑ Exit sensor
- ㉒ Temperature/humidity sensor
- ㉓ Power switch
- ㉔ Paper size switch
- ㉕ Thermistor
- ㉖ Thermal cutout
- ㉗ Network interface card*³

*¹ : FS-1800/1800N
 *² : FS-3800/3800N
 *³ : Standard installed
 for FS-1800N/3800N
 models only.

Figure 4-3-1 Circuit boards, sensors and switches

(2) Motors, solenoids, clutches and others

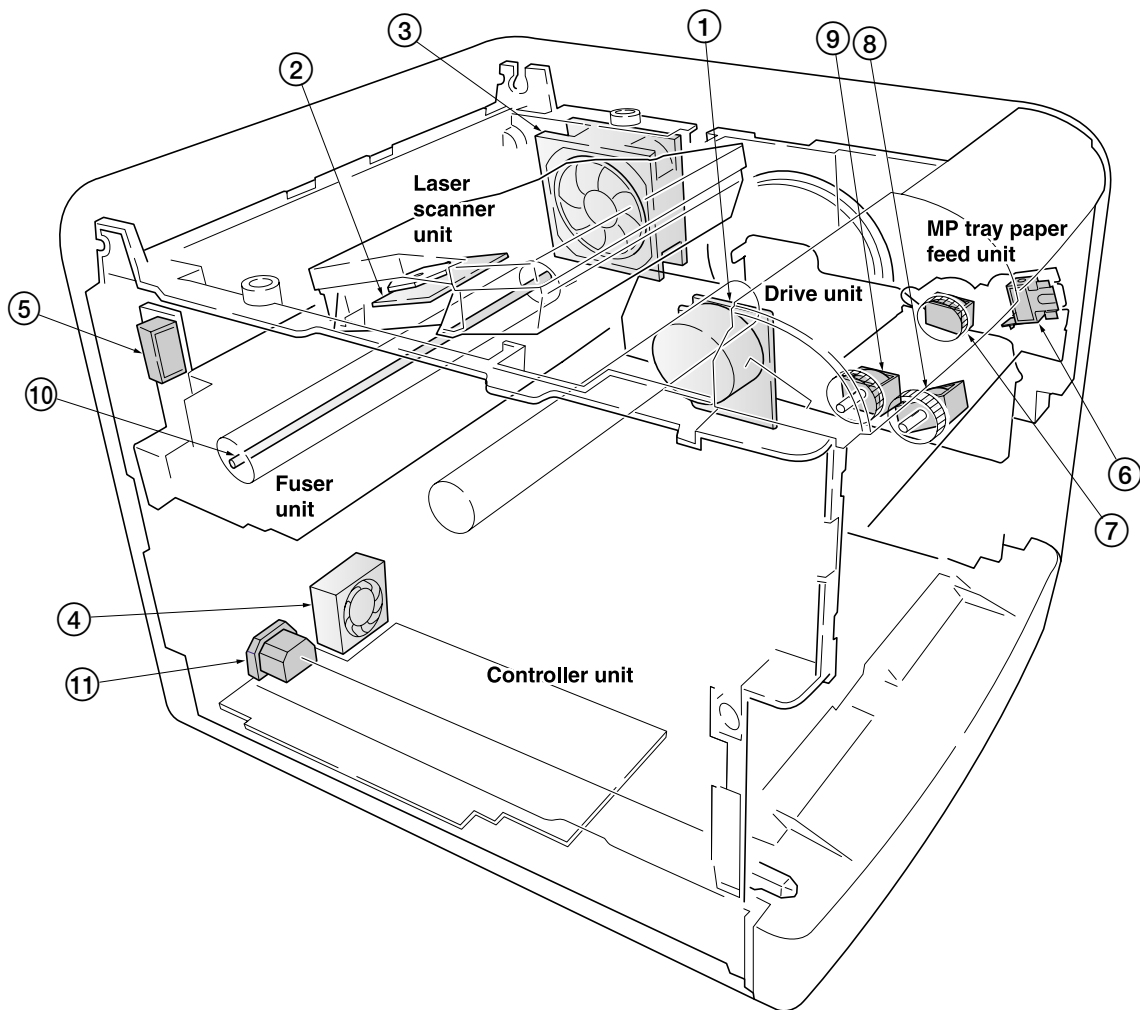

- | | | |
|-----------------------------|-------------------------|-----------------------|
| ① Main motor | ⑤ Face up/down solenoid | ⑨ Registration clutch |
| ② Polygon motor | ⑥ MP feed solenoid | ⑩ Heater lamp |
| ③ Cooling fan motor | ⑦ Middle feed clutch | ⑪ AC inlet |
| ④ Controller unit fan motor | ⑧ Feed clutch | |

Figure 4-3-2 Motors, solenoids, clutches and others

(3) Drum unit and developer

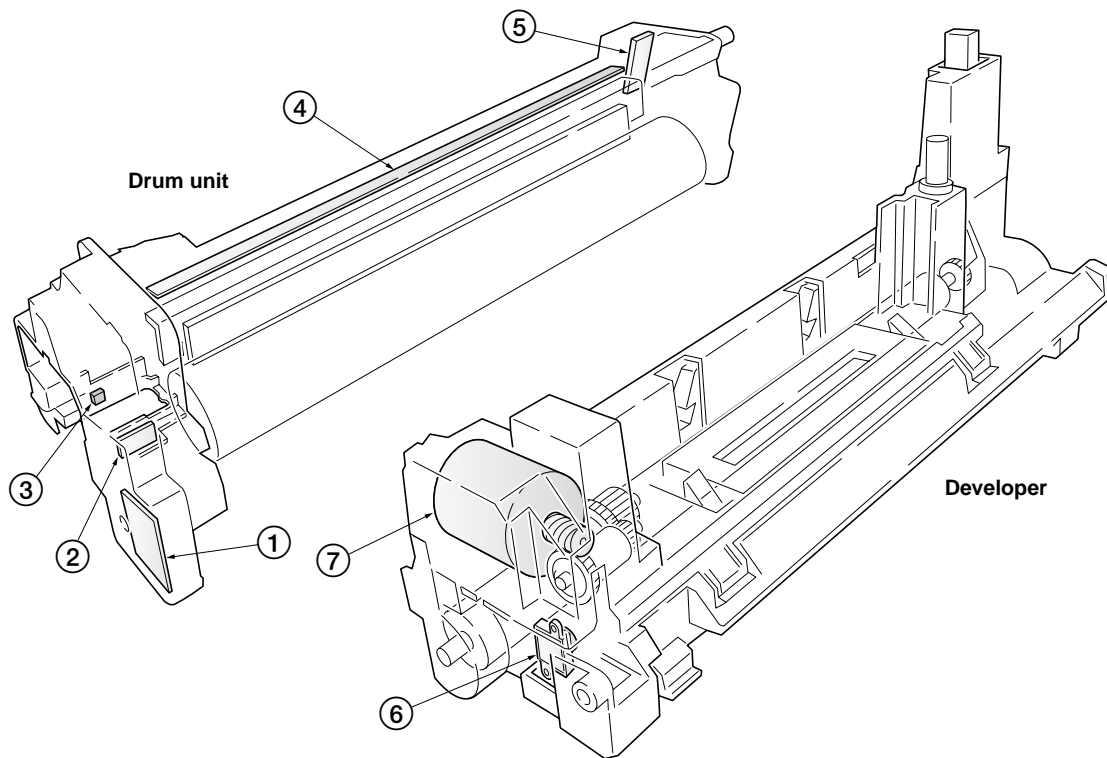

- | | |
|--------------------------------------------|------------------------|
| ① Drum board (KP-748) | ⑤ Zener board (KP-768) |
| ② Waste toner full sensor [board] (KP-766) | ⑥ Toner sensor |
| ③ Waste toner full sensor (receiver) | ⑦ Toner motor |
| ④ Eraser lamp [board] (KP-752) | |

Figure 4-3-3 Drum unit and developer

Main board KP-858 for FS-3800/3800N models

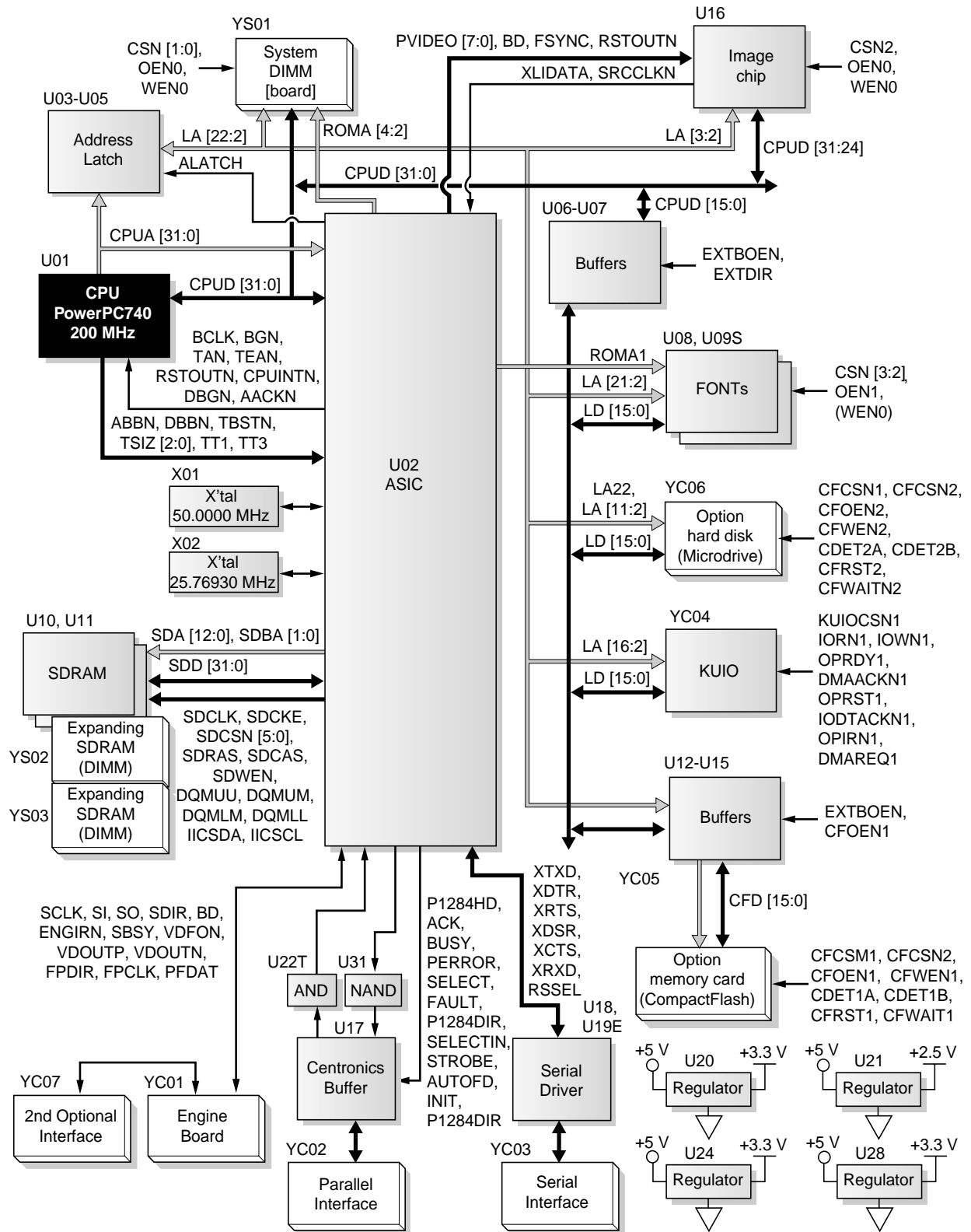

Figure 4-3-5 Main board KP-858 circuit block diagram

(2) Engine board

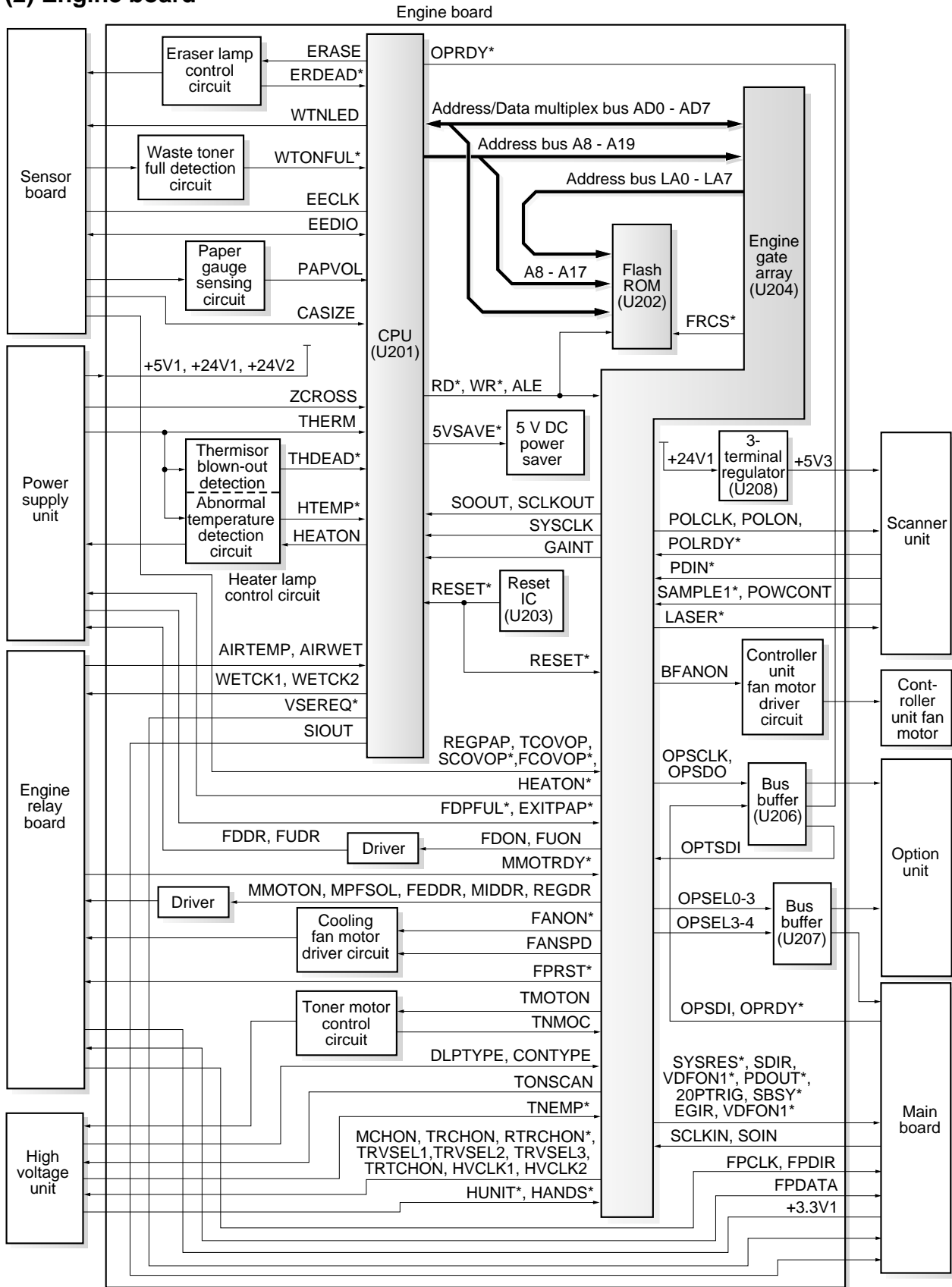

Figure 4-3-6 Engine board circuit block diagram

Eraser lamp control circuit

CPU (U201) turns on its #59 pin to H and turns Q215 and Q214 on. Current flows through Q214 and R249, then the eraser lamp, activating the lamp. Current also routes through R251 and R252 as bled by R251. Point (A) below is approximately 14.5 V when the eraser lamp is normal. If the eraser lamp blows out or the connector is not fitted, current goes through only R251 and R252, subsequently the potential at point (A) is as high as approximately 24 V. Difference in the potential at point (A) where the eraser lamp is normal or not is automatically detected as an error. When anomaly is detected with the eraser lamp, the detector circuit turns Q216 on and turns ERDEAD* at #60 pin of CPU (U201) to L. This in turn causes CPU (U201) to determine that the eraser lamp is faulty, displaying Call service personE5.

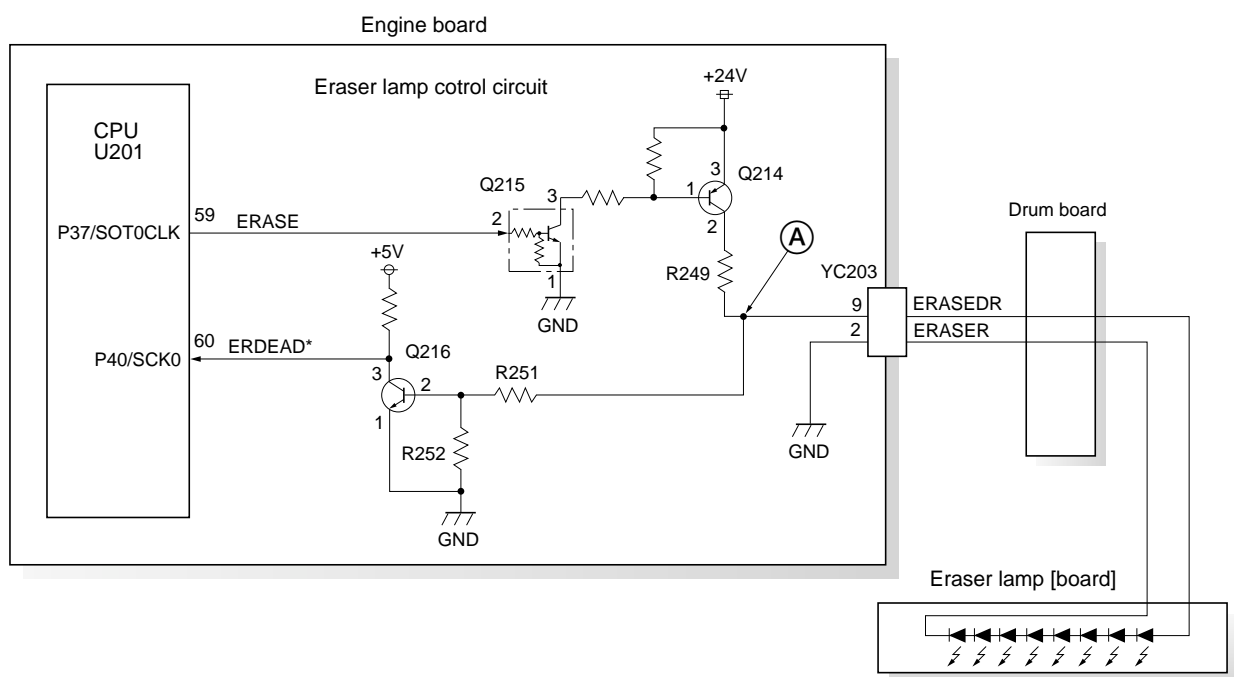

Figure 4-3-7 Eraser lamp control circuit

Toner motor control circuit

As TMOTON at #15 of gate array (U204) turns to H, Q218 and Q217 turn on, and +24 V reaches Q217, R265 and the toner motor, finally driving the toner motor.

If the toner motor is overloaded by some reasons, an overcurrent may flow through the toner motor beyond the predetermined level, turning Q220 on. Q220, when turned on, causes the current from the +24 V power supply to flow through Q217, Q220, R267, R268, and to the ground. Consequently, approximately 3.9 V (H) develops at point (A), as limited by the combination of R267, R268, and DZ206. This voltage is used as TNMOC - toner motor error - which is applied to #17 of CPU (U201). Thus, CPU determines the toner motor error and lets Call service person E9 be indicated.

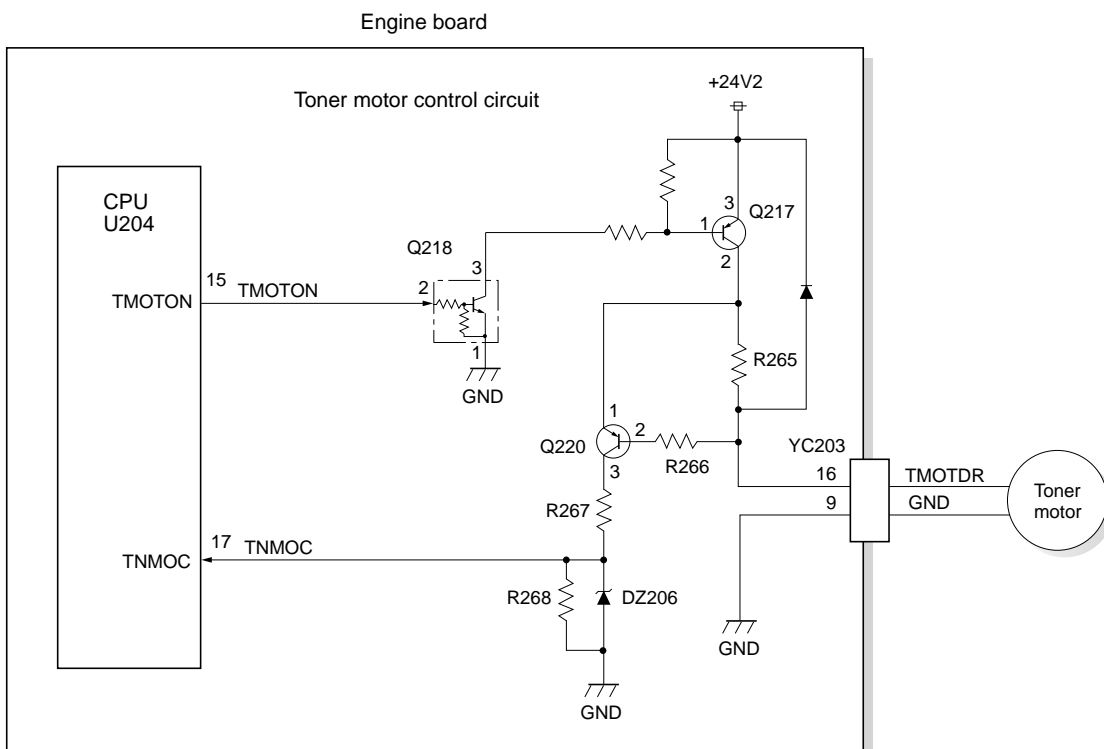

Figure 4-3-8 Toner motor control circuit

Heater lamp control circuit

The heater lamp control circuit turns the heater lamp on and off which is located coaxially inside the heat roller. The surface of the roller maintains the constant temperature needed to permanently fuse the toner on paper.

The heater lamp is directly fed with AC primary power (120 V or 220 - 240 V) which is supplied from the power supply unit.

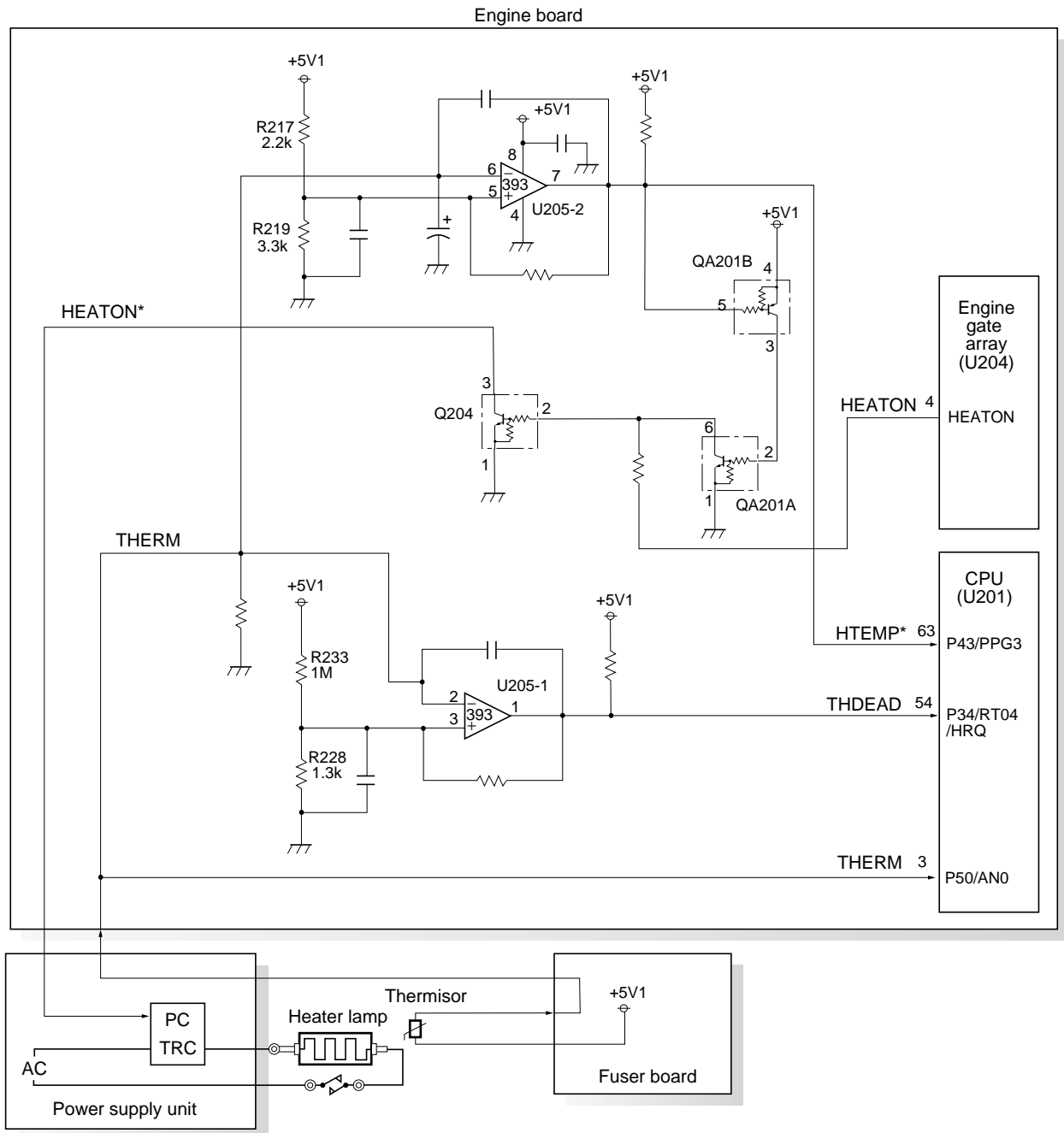

Figure 4-3-9 heater lamp control circuit

As change in temperature is detected by the thermistor, CPU U201 adjusts the voltage that is resultant of change in temperature, given at pin #3 (THERM) to keep the temperature as constant as possible. This voltage is used to continuously switch the fuser lamp on and off. If pin #4 (HEATON) of the engine gate array U204 is H level, transistor Q204 (pin #2) turns on, the photo coupler (PC) on the power supply unit turns on, and the triac (TRC) turns on, consequently the heater lamp is AC powered and lights. The heater lamp continuously turns on and off to maintain the temperature on the heater roller at approximately 185^{*1}/200^{*2} °C (Normal paper, A4), 175^{*1}/190^{*2} °C (Thin paper, A4), and 190^{*1}/205^{*2} °C (Thick paper, A4) for printing and approximately 95 °C at standby (Ready). Refer to section *Fusing* on page 4-15. *1: FS-1800/1800N *2: FS-3800/3800N

Abnormal temperature detection circuit

The thermal cutout device which is connected in series with the heater lamp, constitutes the abnormal temperature detection circuit including of comparators U205-2, R217, R219, etc. Pin #5 of the comparator U205-2 is continuously given with the voltage by resistors R217 and R219, which simulate the voltage given if an abnormally high temperature develops. Pin #6 receives the voltage the thermistor detects. For instance, the heater lamp happens not to switch off, the voltage the thermistor gives at pin #6 will become unusually high, and as soon as it exceeds the voltage at pin #5, pin #7 of the comparator U205-2 output changes to L level. This in turn turns transistors QA201B and QA201A on, and turns QA201A (pin #6) to L level. Since pins #6 of the transistor QA201A and #2 of transistor Q204 are connected to each other, pin #4 of the engine gate array U204, even though it is currently at H level, is enforced to be H level, effectively disabling the heater lamp. Pin #7, the output from comparator U205-2, changes to L. Then, it is output to #63 of CPU (U201) which in turn determines that an unusual temperature has developed in the fuser, indicating Call service personE4.

Thermistor blown-out detection

The thermistor is monitored by the combination of comparator U205-1, R233, and R238. Extremely low potential is applied to pin #3 of U205-1 by means of R233 and R238. Whereas, pin #2 is applied with the voltage the thermistor detects. In normal state, as the heater lamp glows, the voltage detected by the thermistor is greater than the potential at #3 of U205-1, making the U205-1 output to L and sent to #54 (THDEAD) of CPU.

When the thermistor has blown, pin #2 of U205-1 becomes zero which is well lower than the potential at pin #3 of U205-1, the comparator output becomes H, delivering THDEAD at pin #54 of CPU. CPU uses this signal to determine that the thermistor is faulty and displays Call service personE4.

(3) Sensor board

Paper gauge sensing circuit

Paper gauge operates in four levels of paper remaining in the cassette. The height of the paper stack in the paper cassette changes the angle of the actuator. At the end of the actuator is a reflecting mirror which reflects or interrupts the light emitting from photointerruptor sensors PH702 and PH703 accordingly.

These two sensors generate four digital signals which will be digital-analog-converted and input to A/D port of CPU. CPU then issues signals according to the level of the analog signals. The resultant signals are used to monitor the amount of paper in the cassette through the network management utilities.

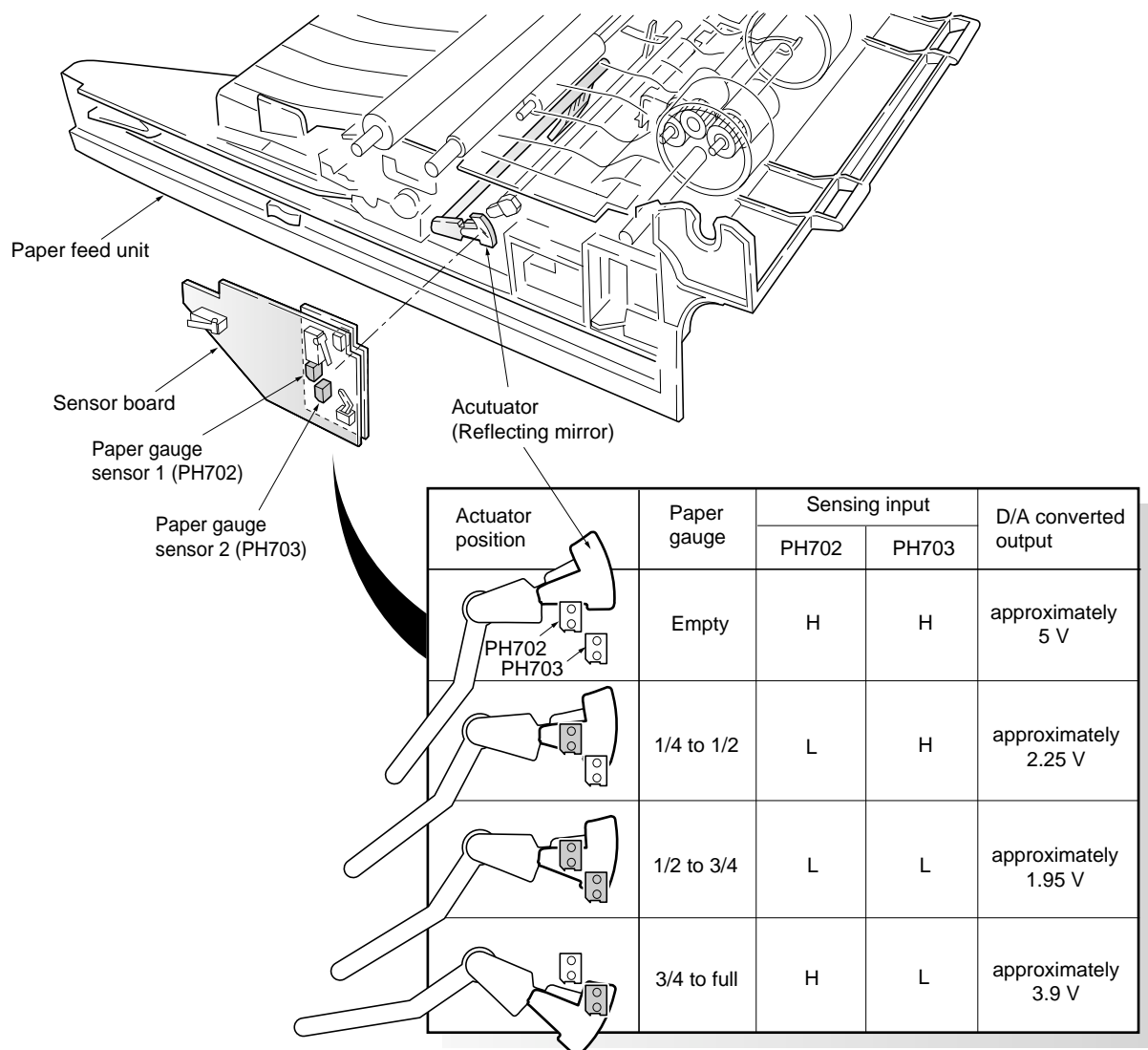

Figure 4-3-10 Paper gauge sensor(s)

Interlock circuit

The interlock circuit is constituted by SW702, the top cover/paper feed unit interlock, and SW703, the side cover interlock, both mounted on the sensor board. These switches are controlled by the actuator which is mechanically activated by the projection on the top cover and the feed unit. SW703 and SW702 are connected in series to the +24 V power. Physically opening the top cover, side cover, or the paper feed unit will disconnect the +24 V power, signaling the status to the engine board. The top cover switch (SW701) serves only the top cover.

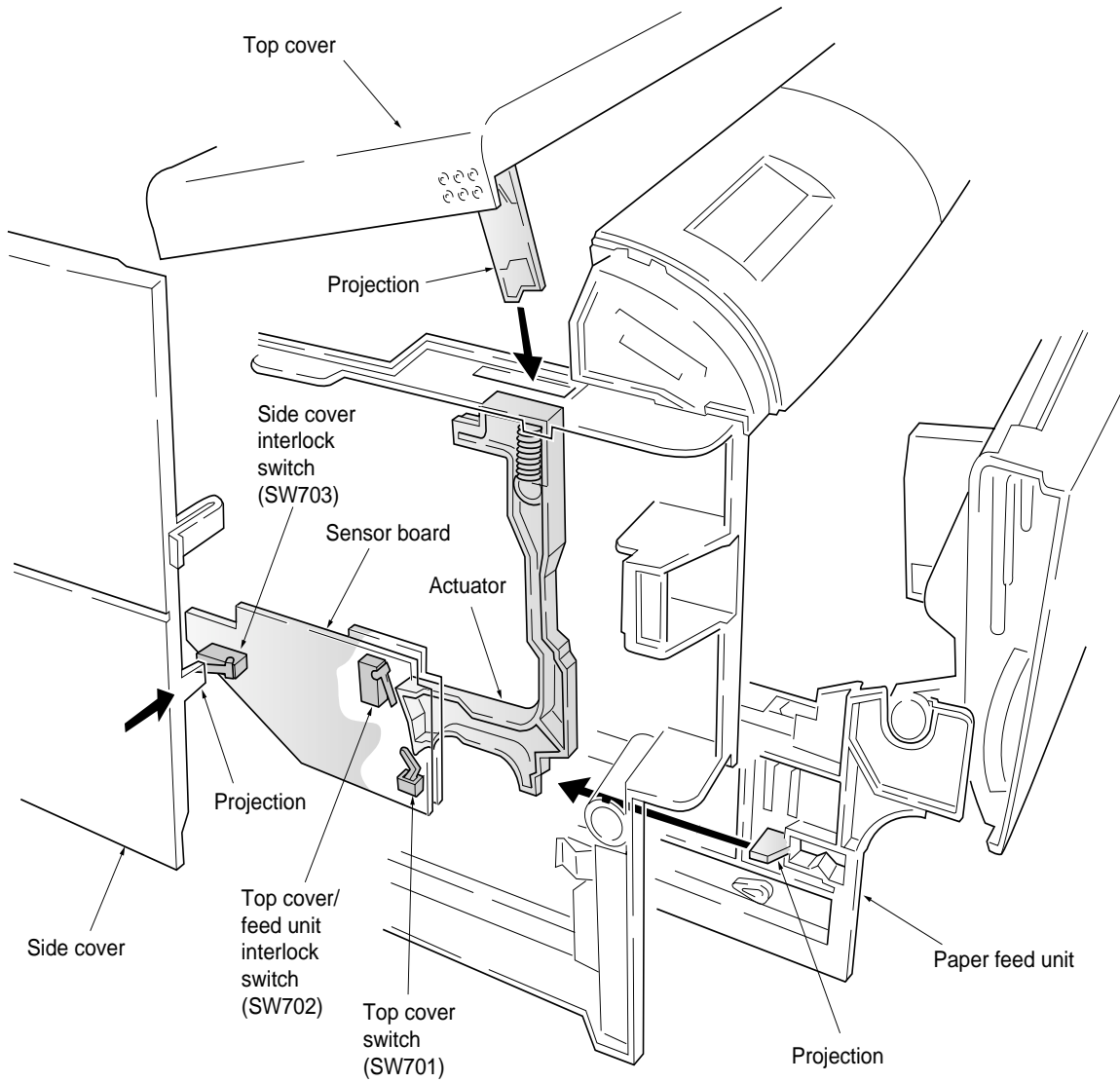

Figure 4-3-11 Interlock system

The interlock circuit outputs the three different detection signals which are combined in matrix to produce various levels of situations regarding the covers. The subsequent status is displayed on the message display.

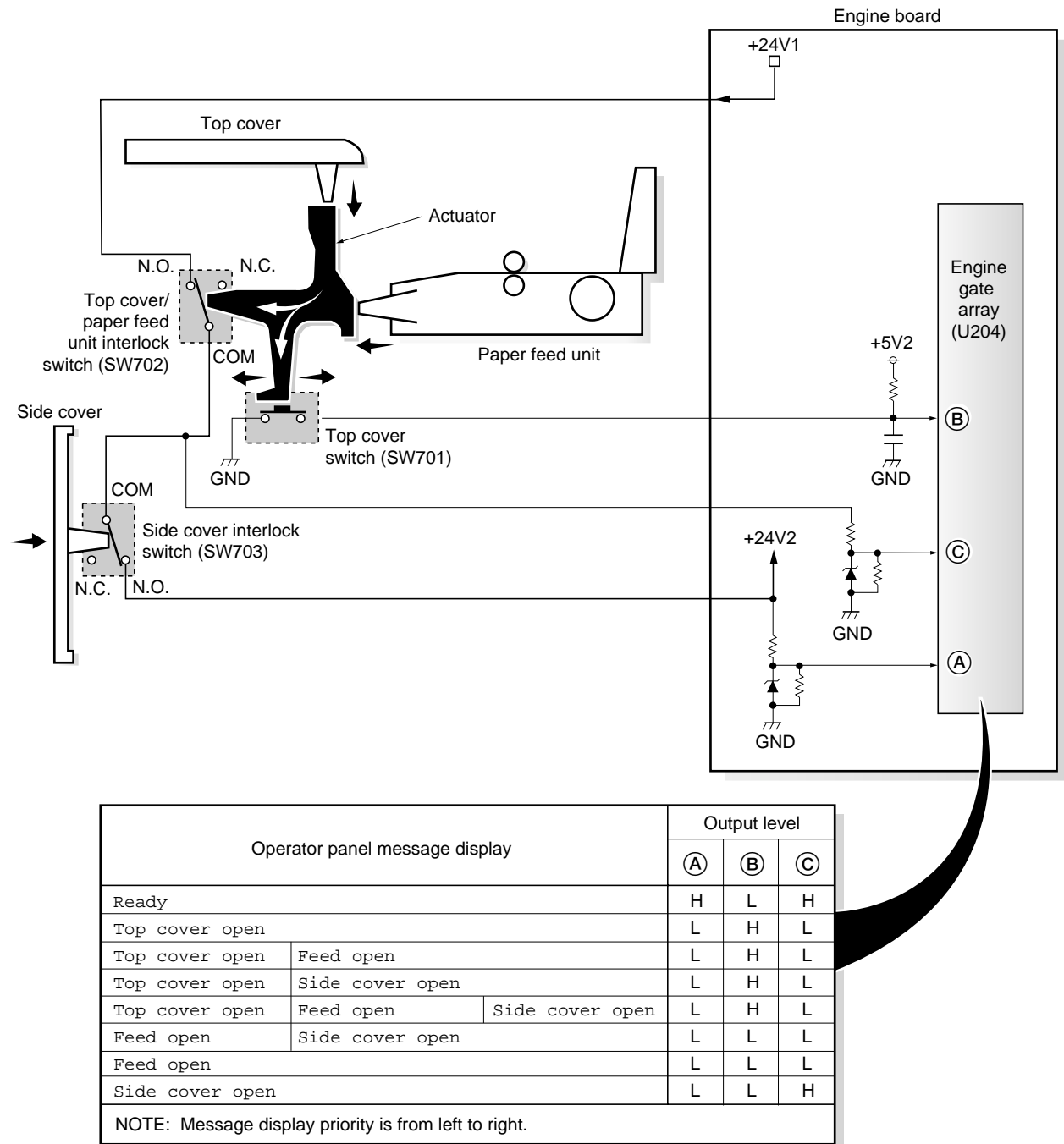

Figure 4-3-12 Interlock circuit

Paper size detecting circuit

The three paper size switches (SW1, SW2, SW3) are activated according to the positioning of the paper size dial on the paper cassette. An analog signal is generated by the combination of the paper size switches, which are put in comparison with the voltage/paper size table referenced by the paper size detecting circuit. The paper size is detected.

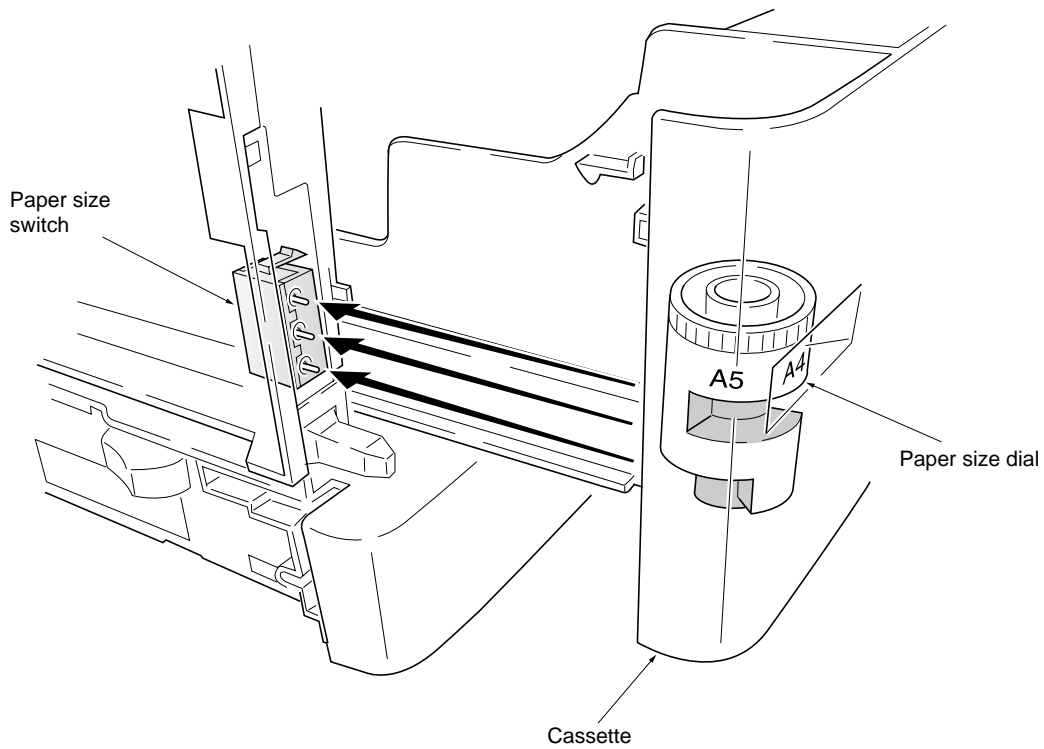
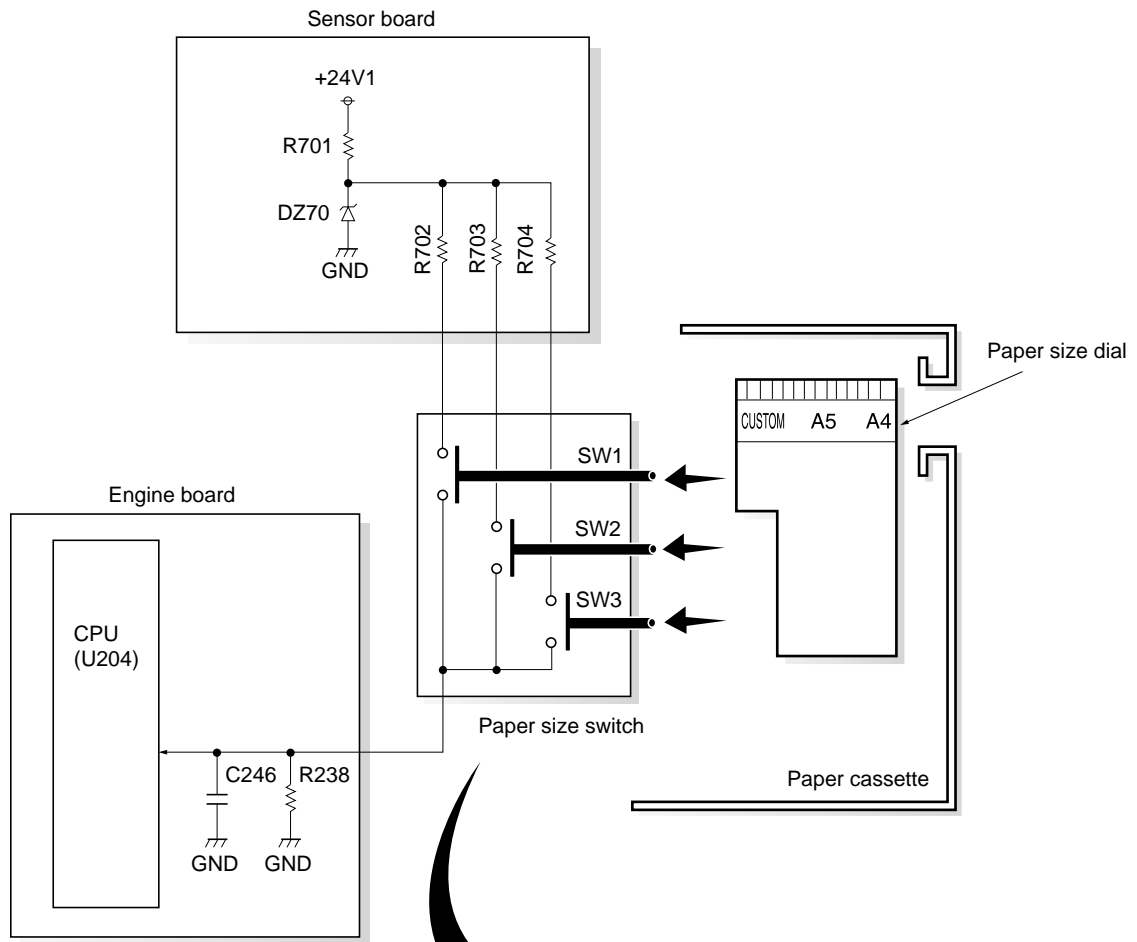
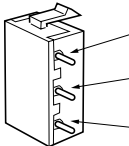
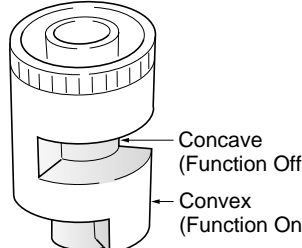
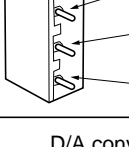
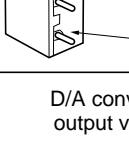

Figure 4-3-13 Paper size detecting circuit

The paper size dial has predetermined patterns of activating the paper size switches using concaves and convexes according to paper sizes. SW1, SW2, and SW3 produce corresponding signals for paper sizes. These patterns are translated into analog voltages and sent to the engine board on a single line. The signals are analog-digital-converted on the engine board.



Paper size switch	Paper size							See note below.	Paper size dial
	Cassette not installed	Other	Legal	A4	A5	B5			
 SW1	Off	Off	Off	On	On	On	On		
 SW2	Off	Off	On	Off	Off	On	On		
 SW3	Off	On	Off	Off	On	Off	On		
D/A converted output voltage	0 V	1.94 V	1.19 V	0.42 V	2.28 V	2.92 V	3.22 V	Approximately	

Note: Toner install mode cancellaton signal (See page 3-14)

Figure 4-3-14 Paper size detecting circuit

(4) Power supply unit

The power supply unit produces DC power outputs from the AC input. The high voltage bias generator circuit is mounted on a separate unit.

A simplified schematic diagram is shown below.

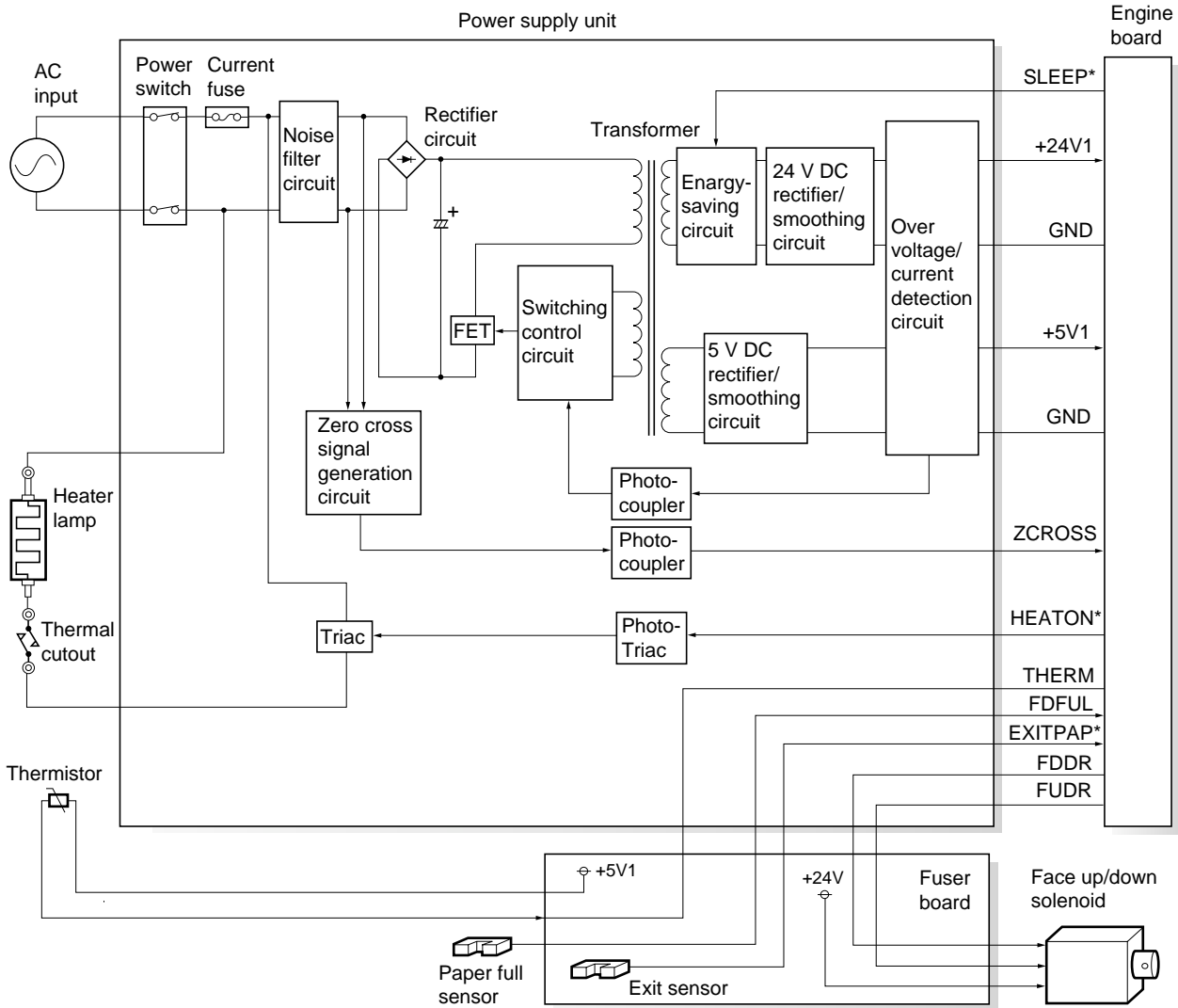

Figure 4-3-15 Power supply unit circuit block diagram

(5) High voltage unit

High voltage unit contains main charger unit, transfer roller high voltage output circuit which generates the developer bias. It also contains MP tray paper sensor and option feeder sensor.

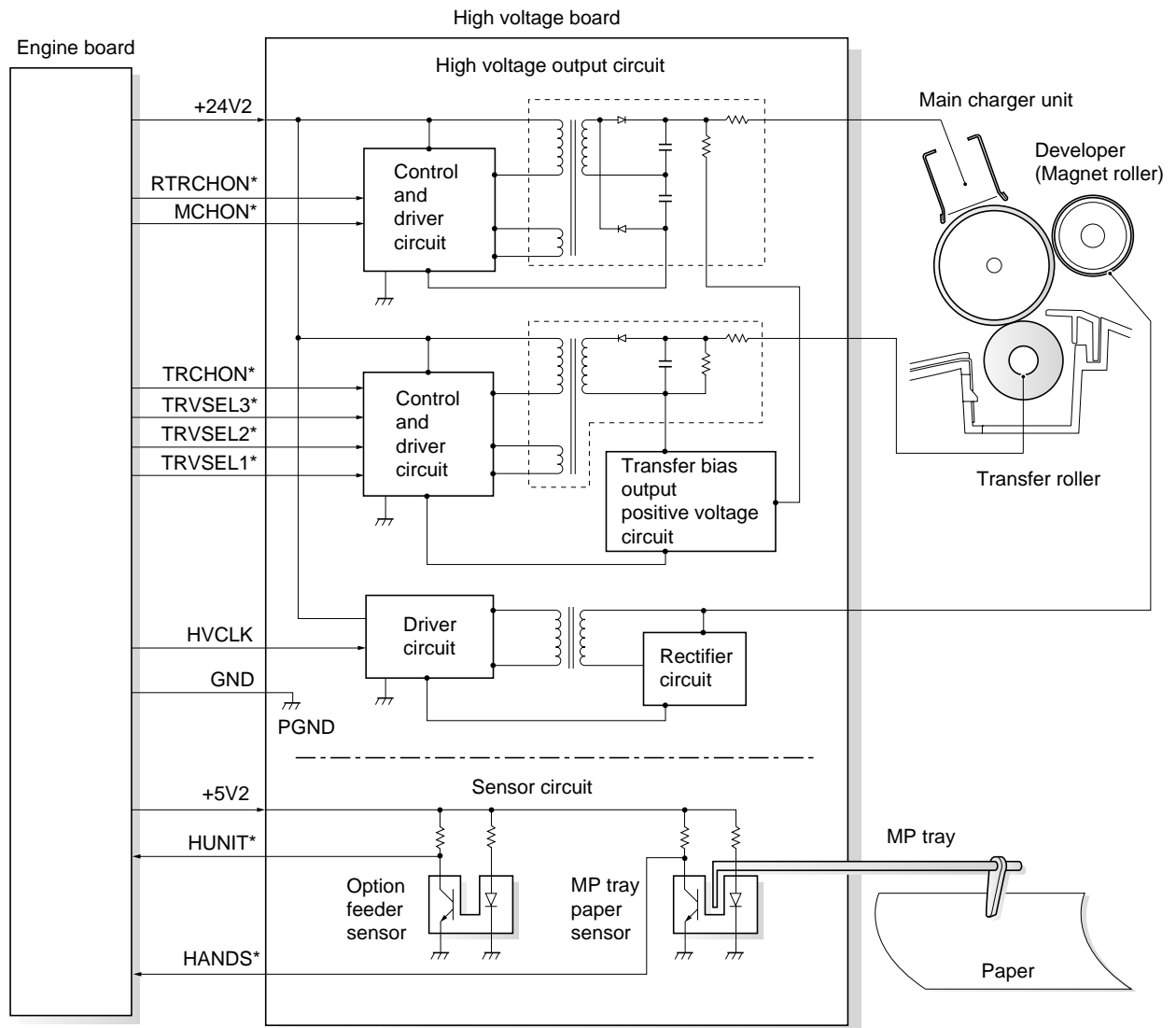

Figure 4-3-16 High voltage unit circuit block diagram

Chapter 5 D i s a s s e m b l y

Chapter 5 Contents

5-1 General instructions	5-3
5-1-1 Screw/hardware	5-3
5-1-2 Before starting disassembly	5-3
5-2 Disassembly	5-4
5-2-1 Removing the developer	5-4
(1) Removing the developer	5-4
5-2-2 Removing the paper feed unit	5-6
5-2-3 Removing the main charger unit	5-7
5-2-4 Removing the operator panel and outer covers	5-8
(1) Removing the operator panel	5-8
(2) Removing the top cover/face-down output tray	5-9
(3) Removing the right cover	5-10
(4) Removing the left cover	5-11
5-2-5 Removing the drum unit	5-12
5-2-6 Removing the pickup roller and feed roller	5-13
5-2-7 Removing the MP paper feed unit	5-15
5-2-8 Removing the transfer roller	5-17
5-2-9 Removing the controller unit and the principal circuit boards	5-18
(1) Removing and opening the controller unit	5-18
(2) Removing the engine board and power supply unit	5-22
(3) Removing the main board	5-24
(4) Removing the high voltage unit	5-25
(5) Removing the sensor board	5-26
5-2-10 Removing the drive unit and main motor	5-27
5-2-11 Removing and splitting the fuser unit	5-29
(1) Removing the separators	5-32
(2) Removing the heater lamp	5-33
(3) Removing the heat roller	5-34
(4) Removing the thermistor and the thermal cutout	5-35
(5) Removing the press roller	5-36
5-2-12 Removing the laser scanner unit	5-37

5-1 General instructions

This chapter provides the procedure for removal and replacement of field replacement components. For other components not explained in this chapter, it is recommended that you refer to the diagrams in the Parts Catalog as a supplemental reference to this chapter. It features all the part drawings and help you disassemble or refit the parts in the printer.

When replacing of a component, reverse the procedure for the removal procedure explained in this chapter.

WARNING



To avoid injury caused by electric shock, make sure that AC power is removed and the power cord is unplugged from both the power line and the printer.

5-1-1 Screw/hardware

Screws and hardware used in the printer are listed in the *Ecosys Screw catalog*. These screw symbol numbers are universal to most Ecosys printers.

CAUTION



When securing a self-tapping screws, align it with the thread carefully. First turn it counterclockwise, then slowly clockwise. Do not overtighten. In case the self-tapped thread is damaged, the whole part may have to be replaced with a new part.

5-1-2 Before starting disassembly

Before proceeding, unplug the power cord from the printer and the power supply.

WARNING



Never attempt to operate the printer with components removed.

CAUTION



The printer use electrostatic sensitive parts inside (circuit boards, laser scanner unit, etc.). Provide an antistatic (discharging) device, such as a wrist strap, that can effectively discharge your body before touching those components.

5-2 Disassembly

5-2-1 Removing the developer

(1) Removing the developer

CAUTION When installing or removing the developer, do not let the magnet roller touch any part in the printer.

When handling developer, use both hands. Do not press the bottom of the developer.

1. Open the top cover.
2. Remove the toner container.
3. Disconnect the developer connector ①.
4. Remove the developer ② from the printer while sliding the developer lock lever ③ frontwards.

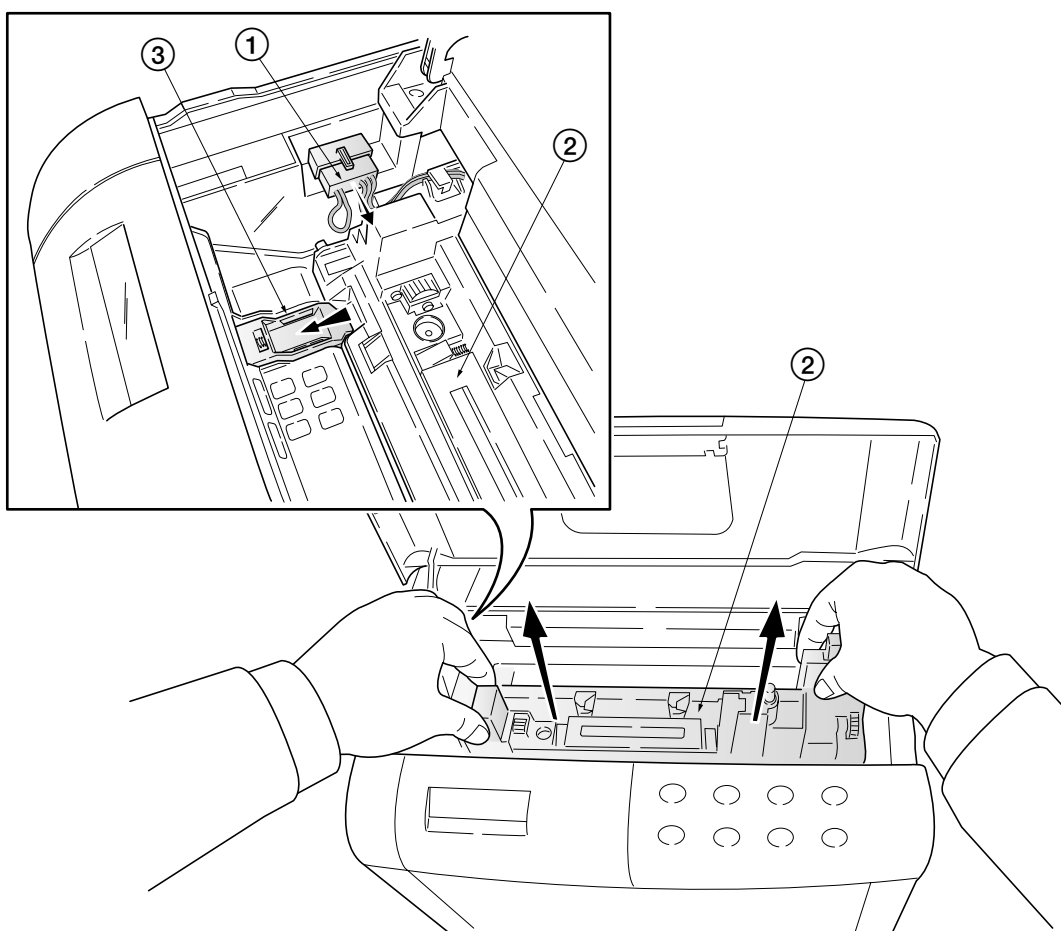

Figure 5-2-1 Removing the developer

5. Gently flip down the magnet roller protective cover ④.

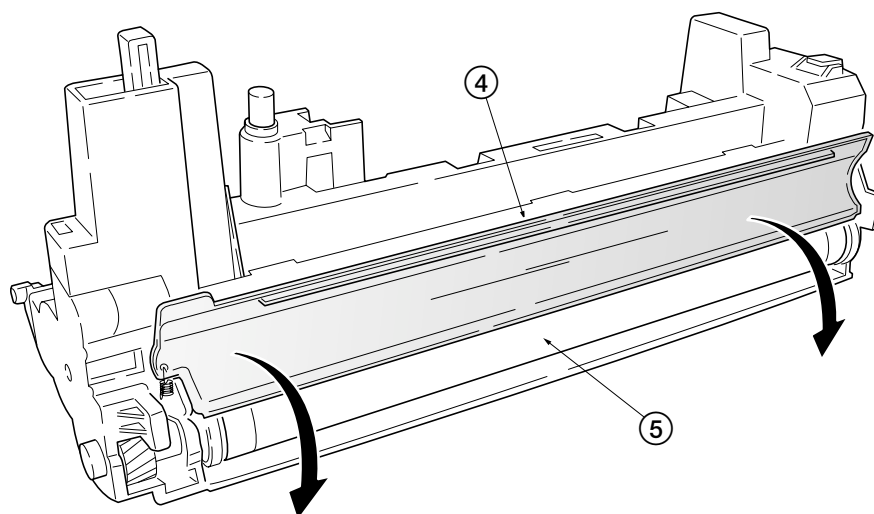

Figure 5-2-2 Closing the magnet roller protective cover

NOTE

After removing the developer, seal it in the protective bag and place it on a flat surface. Do not place the developer in a dusty area. If you ship the developer, pack it in the shipping container specifically supplied with the printer. See section *Shipping the developer* on page 3-13. Also do not touch the developing roller ⑤. Do not place floppy disks near the developer.

5-2-2 Removing the paper feed unit

1. Draw the paper feed unit ① while pressing the buttons in the direction of arrow ②.

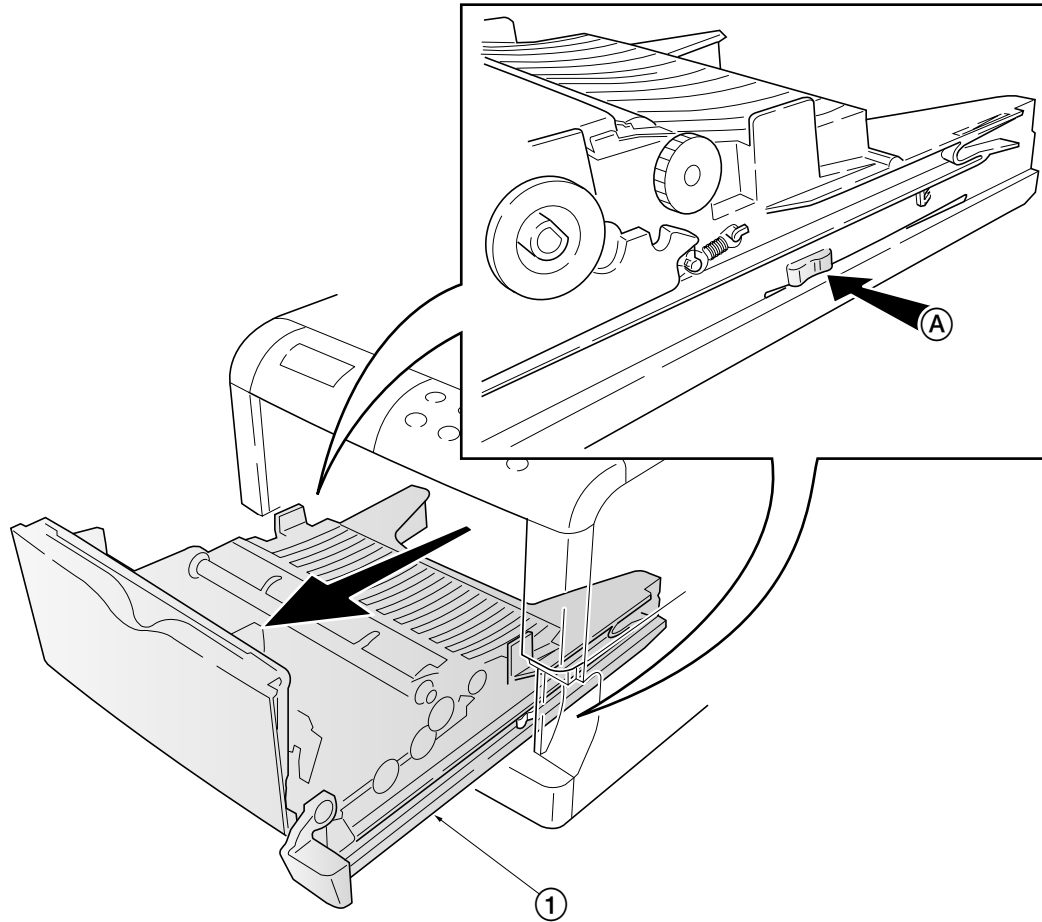

Figure 5-2-3 Removing the paper feed unit

5-2-3 Removing the main charger unit

- 1. Pull the main charger unit ① upwards while pushing main charger release lever ②. Then, pull the main charger unit ① frontwards.

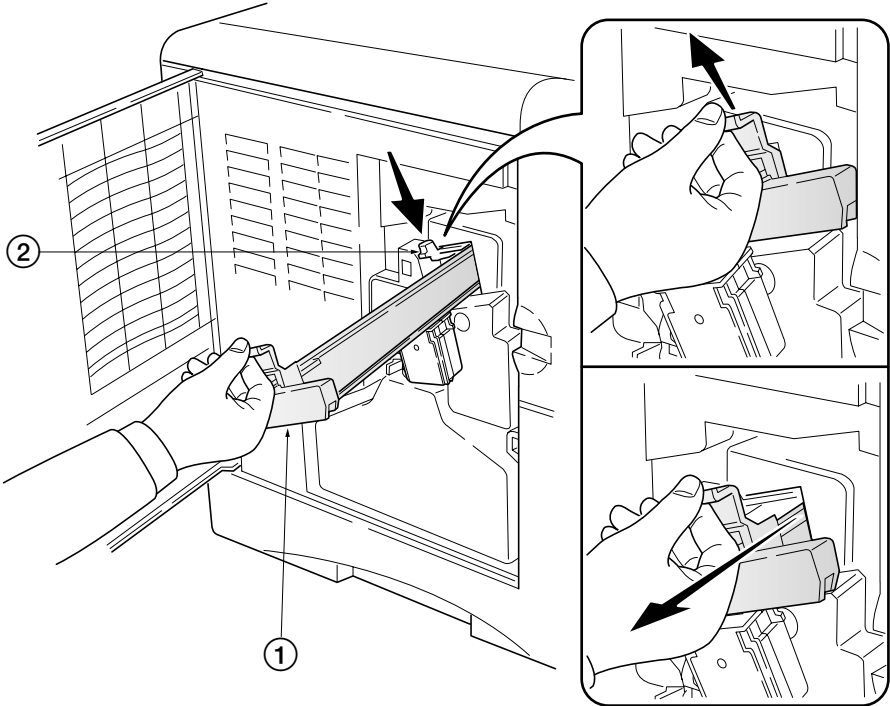

Figure 5-2-4 Removing the main charger unit

5-2-4 Removing the operator panel and outer covers

(1) Removing the operator panel

1. Open the top cover ① and MP tray ②.
2. Unlatch two hooks ③.
3. Pull the operator panel ④ towards the front.

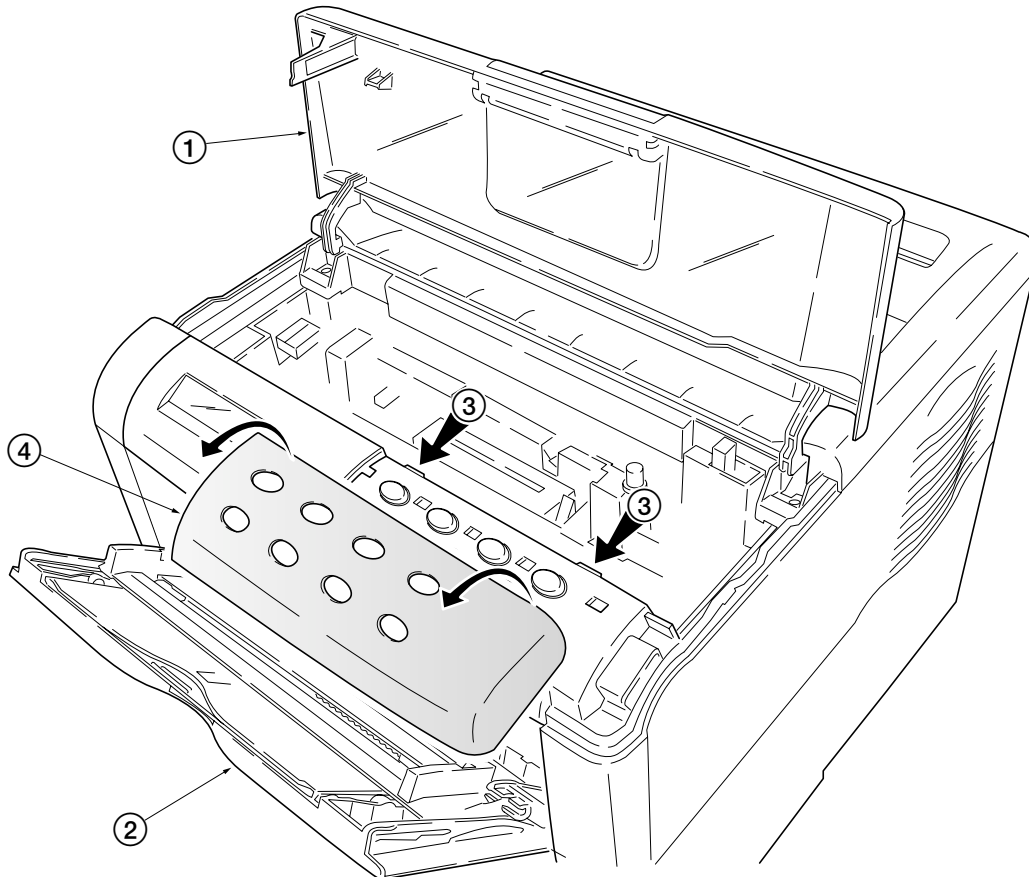

Figure 5-2-5 Removing the operator panel

(2) Removing the top cover/face-down output tray

1. Open the top cover ①.
2. Remove two screws ②.
3. Remove the top cover/face-down output tray ③ while pressing it the direction arrows ④ (backwards).

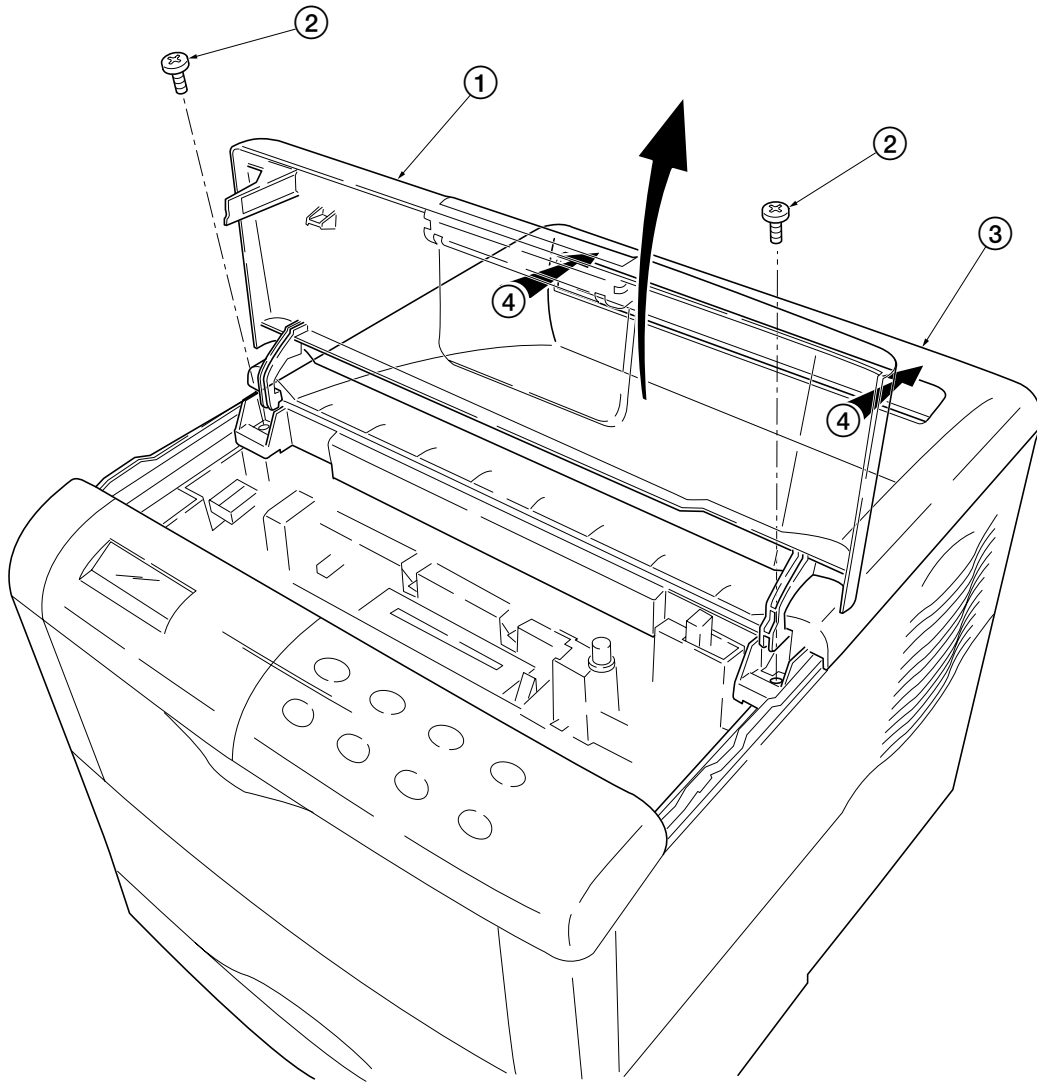

Figure 5-2-6 Removing the top cover/face-down output tray

(3) Removing the right cover

1. Remove the operator panel. See page 5-8.
2. Unlatch the four snaps (1) and three hooks (2) on the chassis. Remove the right cover (3).

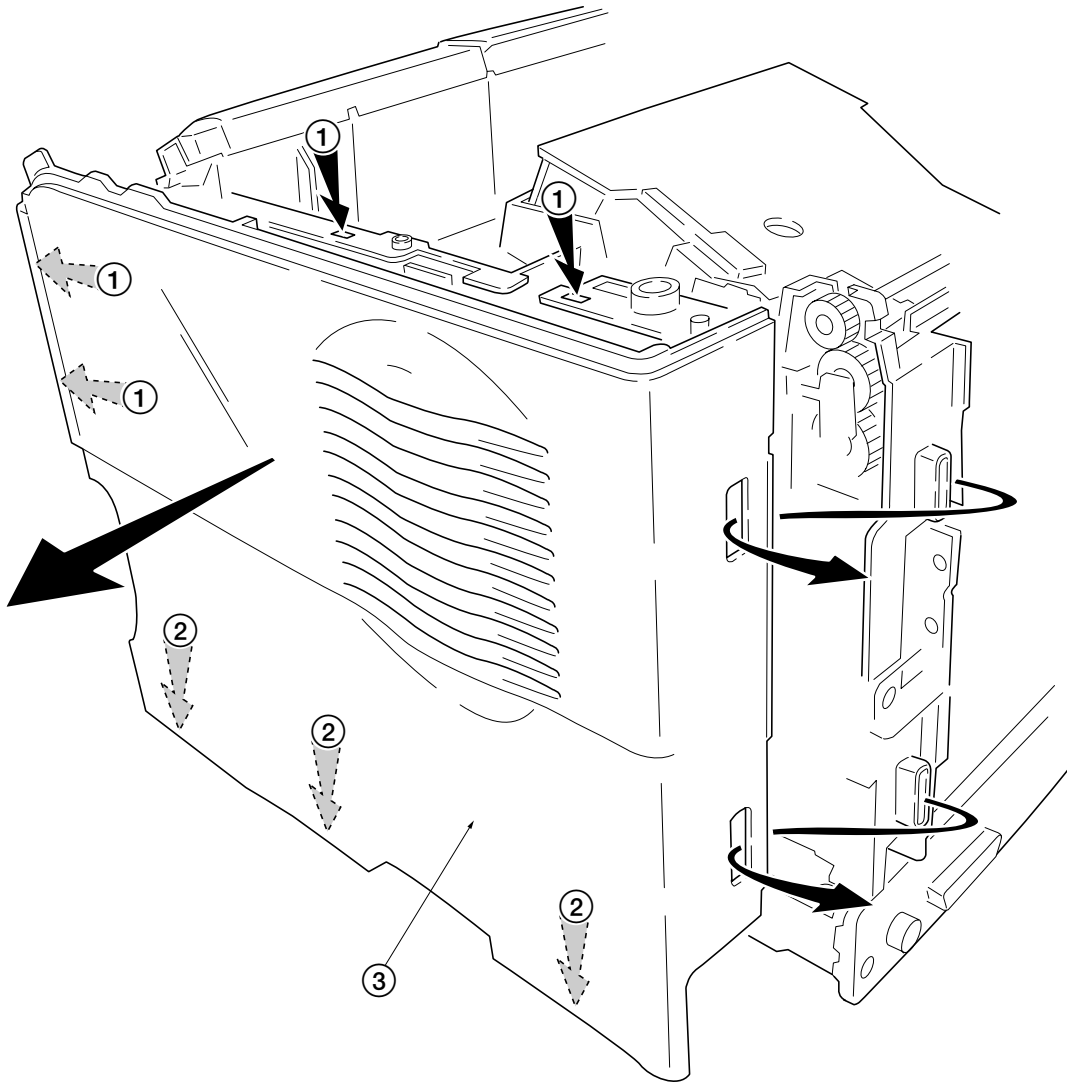

Figure 5-2-7 Removing the right cover

(4) Removing the left cover

1. Unlatch the four snaps ① and three hooks ② on the chassis. Remove the left cover ③.

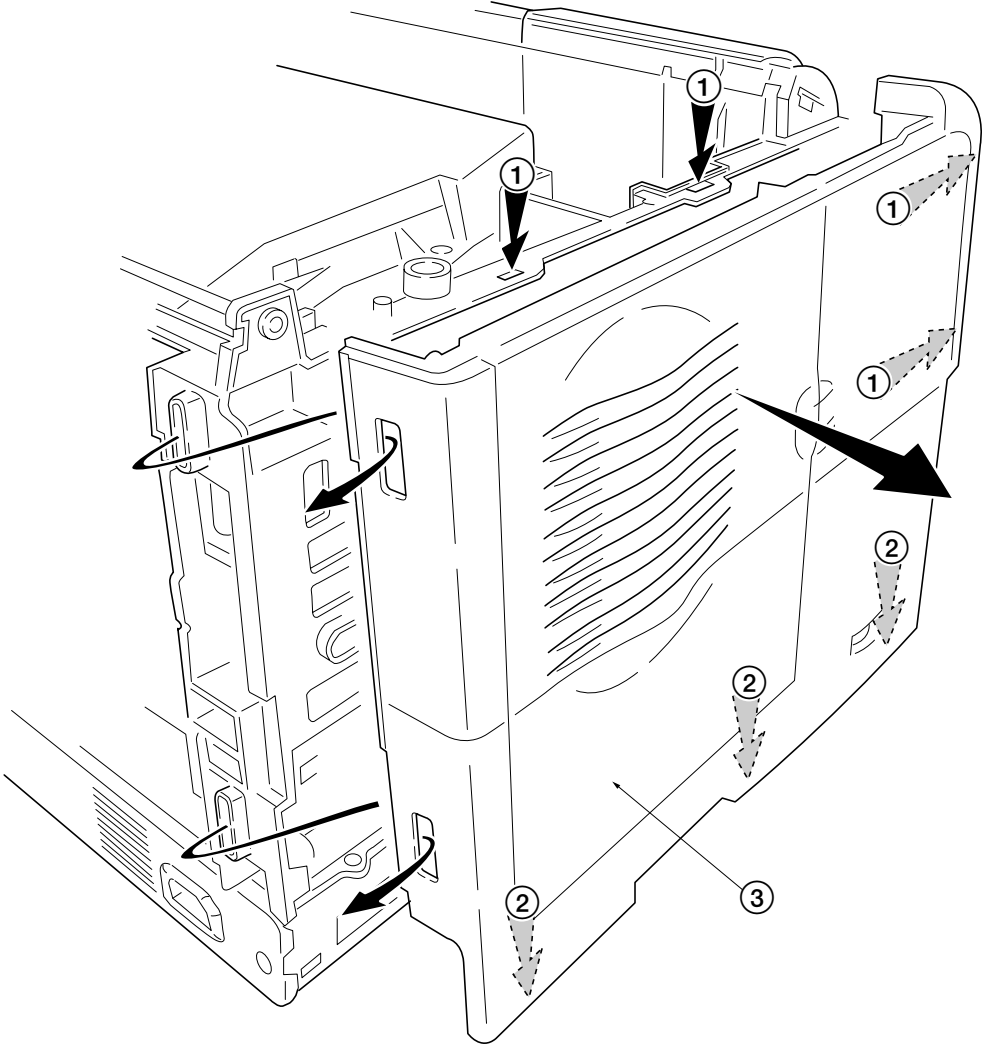

Figure 5-2-8 Removing the left cover

5-2-5 Removing the drum unit

1. Remove the paper cassette and the paper feed unit. See page 5-6.
2. Remove the developer unit. See page 5-4.
3. Remove the waste toner bottle. See page 3-7.
4. Remove the drum unit ① while pressing the drum lock ②.

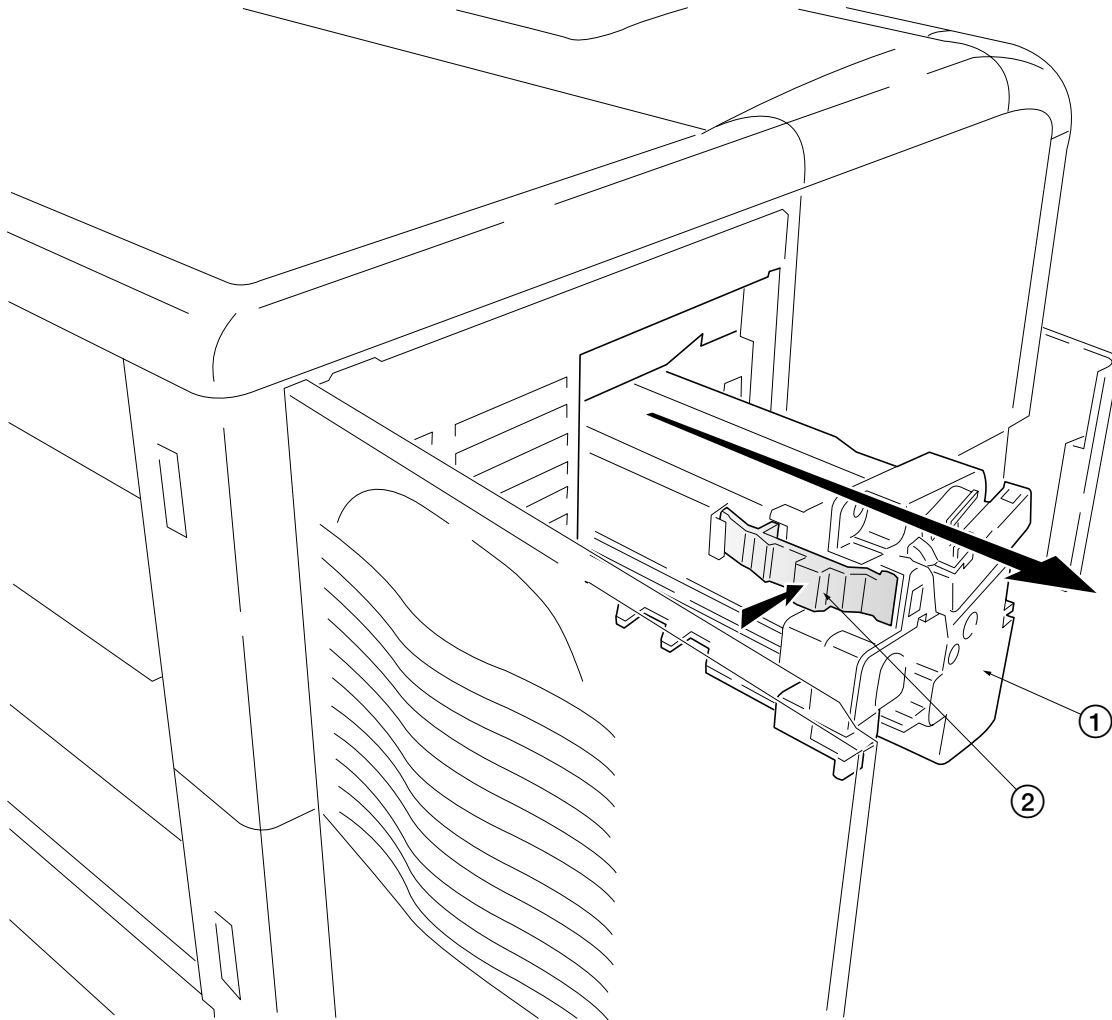

Figure 5-2-9 Removing the drum unit

5-2-6 Removing the pickup roller and feed roller

1. Remove the paper feed unit. See page 5-6.
2. Turn the paper feed unit ① over.
3. Detach the release holder ② by sliding it while pressing the projections ④.
4. Remove the feed roller assembly ③ while pressing it in the direction of arrow ⑤.

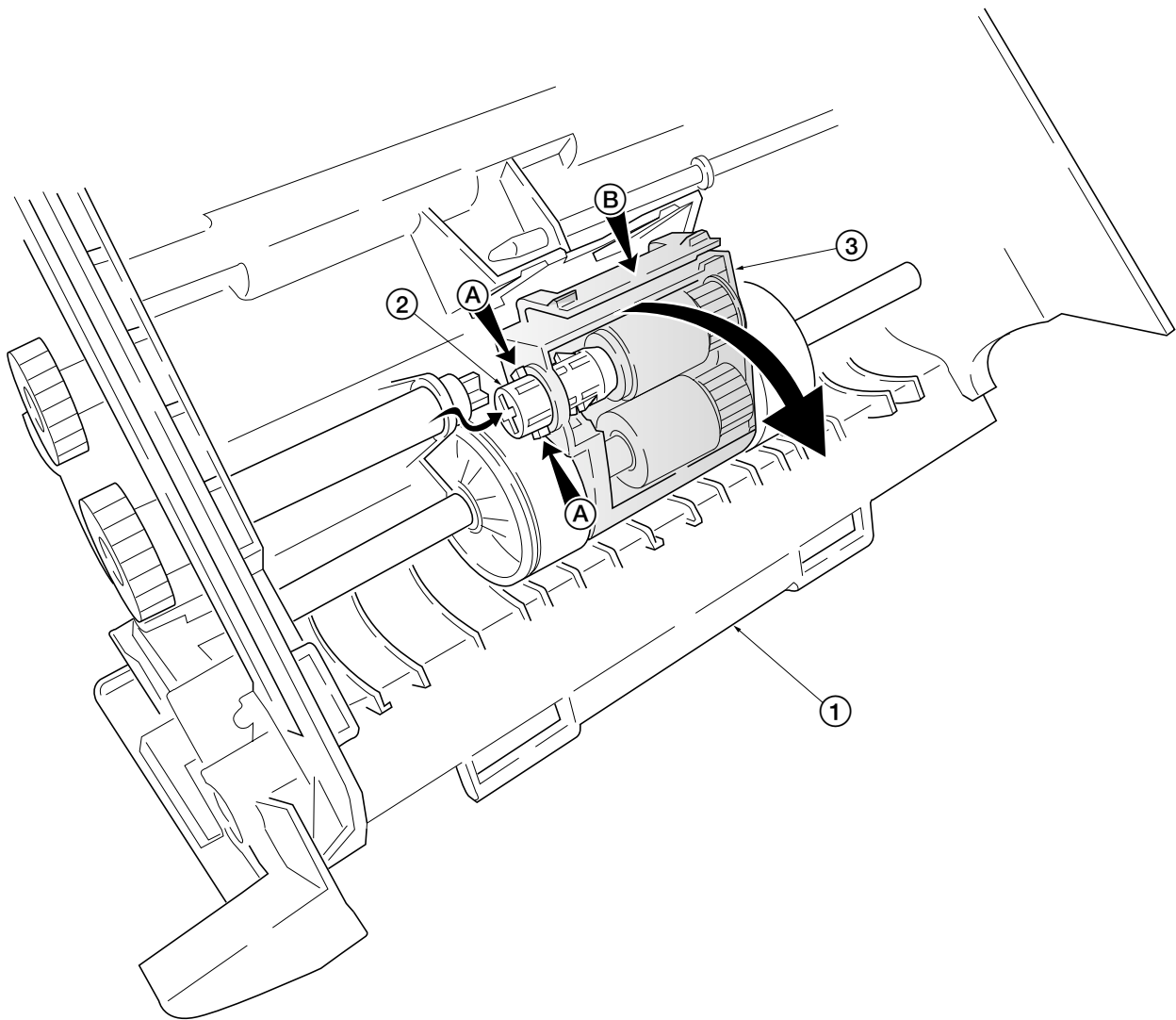

Figure 5-2-10 Removing the feed roller assembly

5. Remove the feed bracket cover (4) while unlatching three snaps (5).
6. Remove the pickup roller (6) and the feed roller (7).

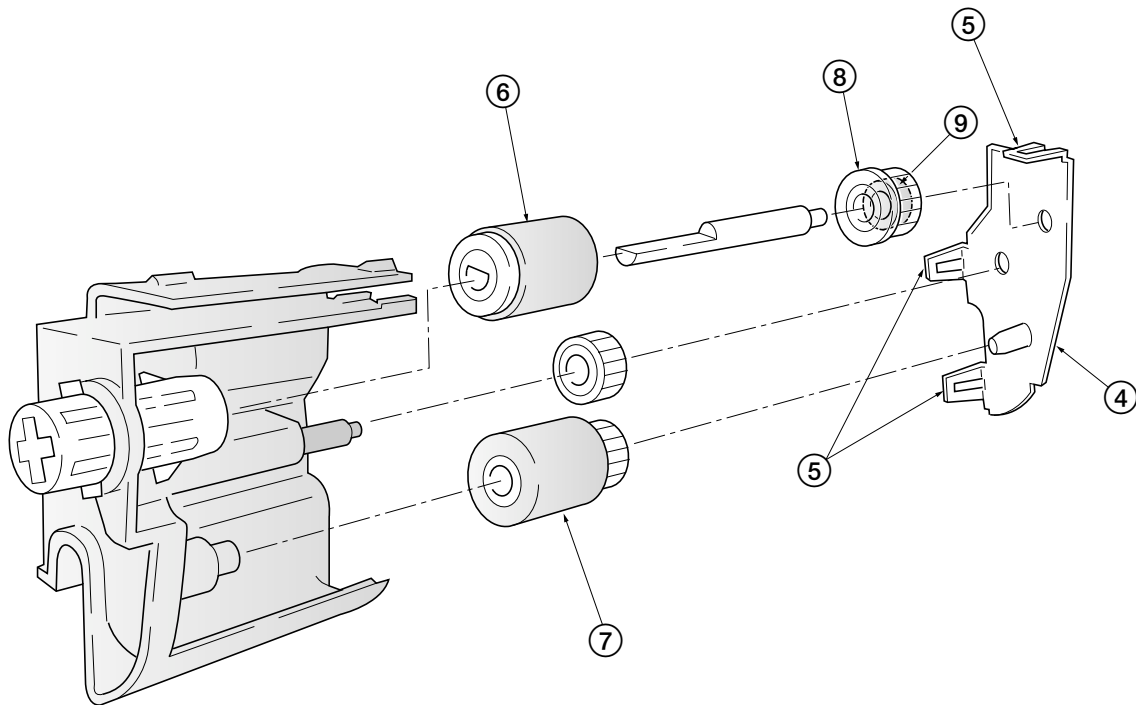

Figure 5-2-11 Remove the pickup roller and feed roller

CAUTION



Pickup gear Z32S (8) is installed on the inside of the one way clutch (9). When refitting pickup gear Z32S (8), face the one way clutch (9) face to the feed bracket cover (4).

5-2-7 Removing the MP paper feed unit

1. Remove the paper feed unit. See page 5-6.
2. Remove the developer. See page 5-4.
3. Remove three connectors ①.
4. Remove the engine relay board ② while unlatching the latches ③.

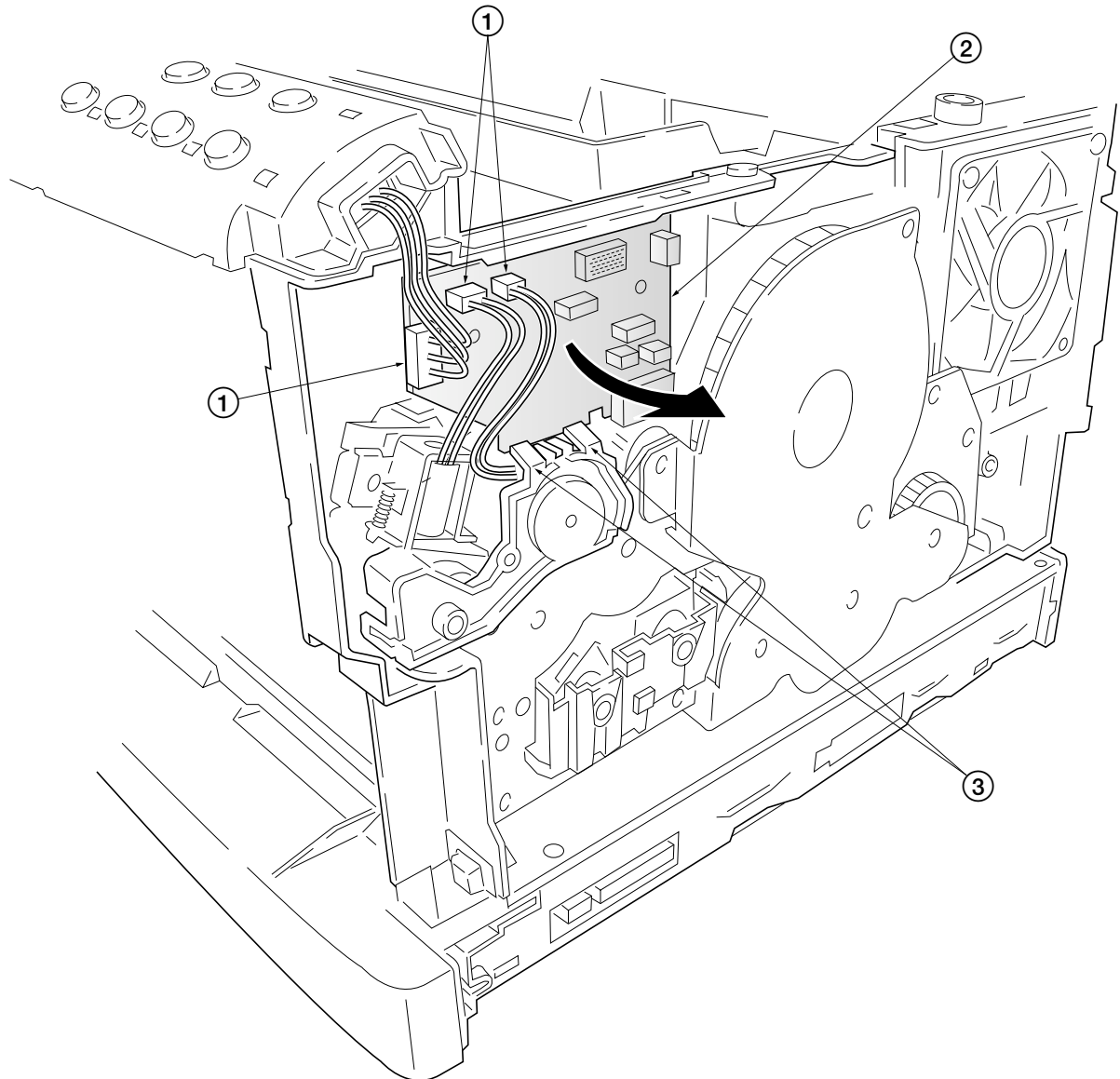

Figure 5-2-12 Removing the engine relay board

5. Pull the MP tray paper feed unit ④ out while unlatching two latches ⑤ off of points ①.

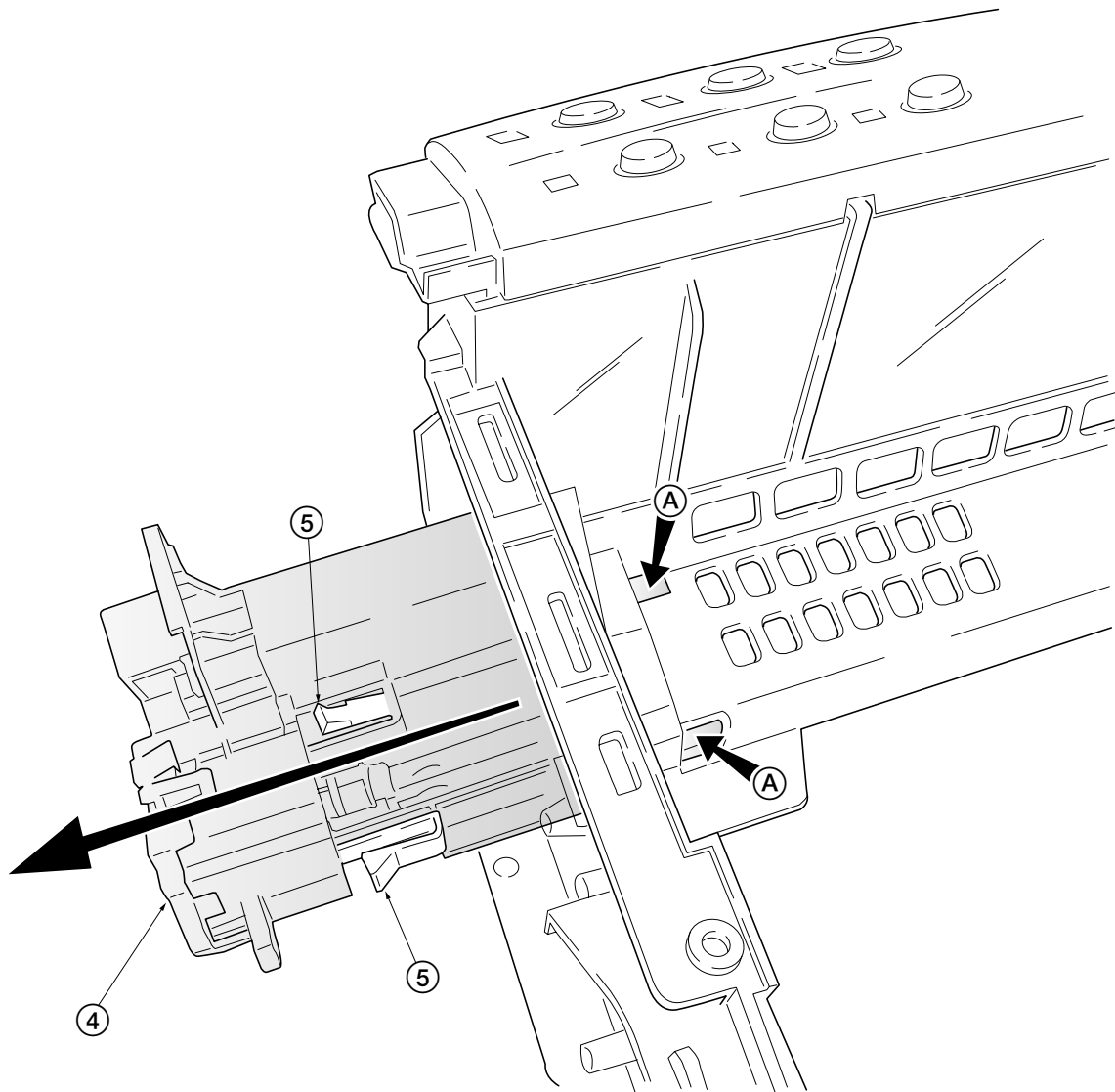

Figure 5-2-13 Removing the MP paper feed unit

5-2-8 Removing the transfer roller

CAUTION



Do not touch the transfer roller ① (sponge) surface. Oil and dust (particles of paper, etc.) on the transfer roller ① can significantly deteriorate the print quality (white spots, etc.).

1. Draw the feed unit from the printer.
2. Remove the paper chute ②.
3. Remove the transfer roller ①.

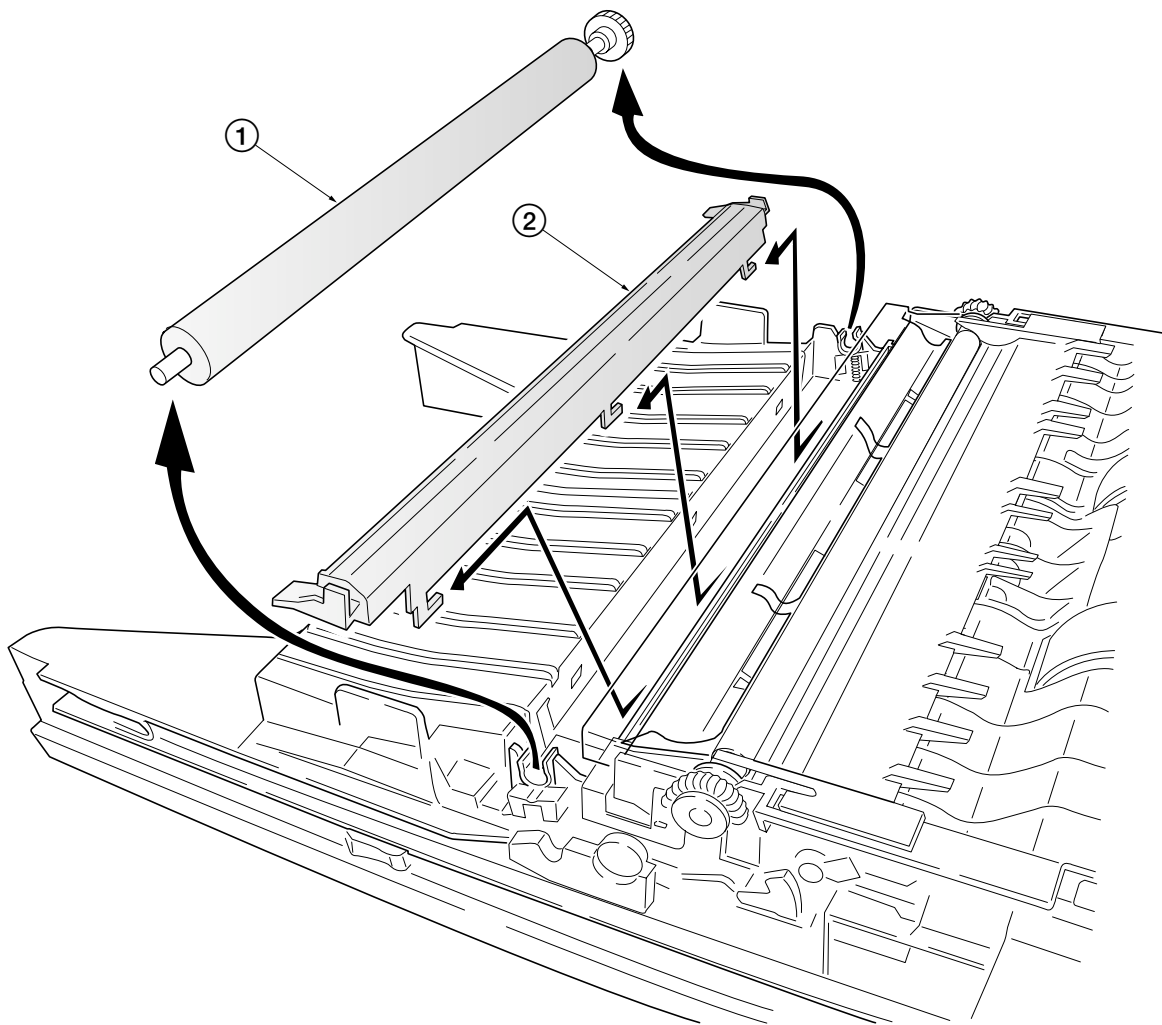

Figure 5-2-14 Removing the transfer roller

5-2-9 Removing the controller unit and the principal circuit boards

(1) Removing and opening the controller unit

1. Remove the top cover/face-down output tray. See page 5-9.
2. Remove the right and left covers. See page 5-10 and 5-11.
3. Remove the four connectors ① from the controller unit ② left side.

CAUTION Draw the connector straight to remove. If you draw the connector while it is slanted, the receptacle may be damaged.

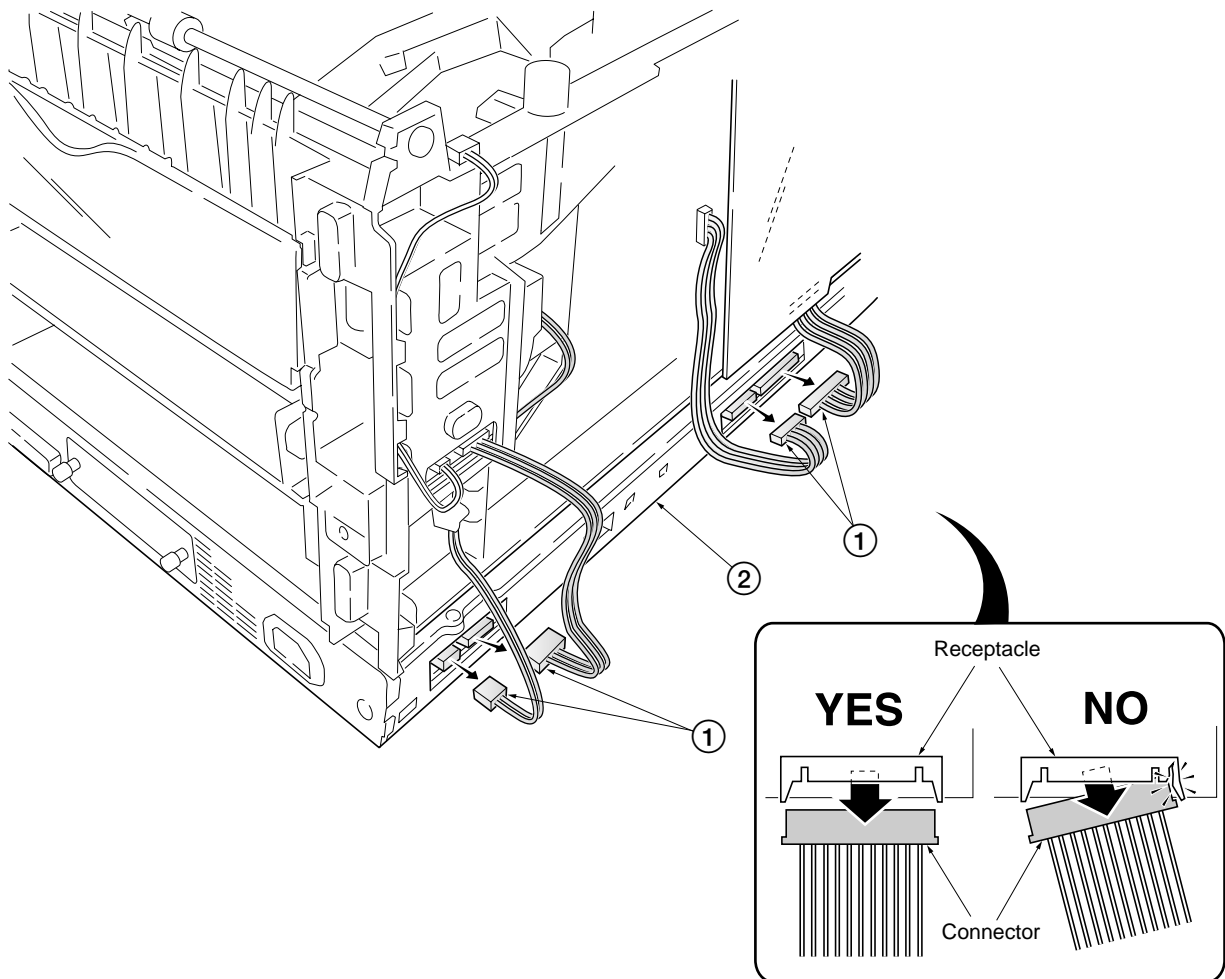

Figure 5-2-15 Removing the connectors from controller unit left side

4. Remove the two connectors ③ from the controller unit ② right side.

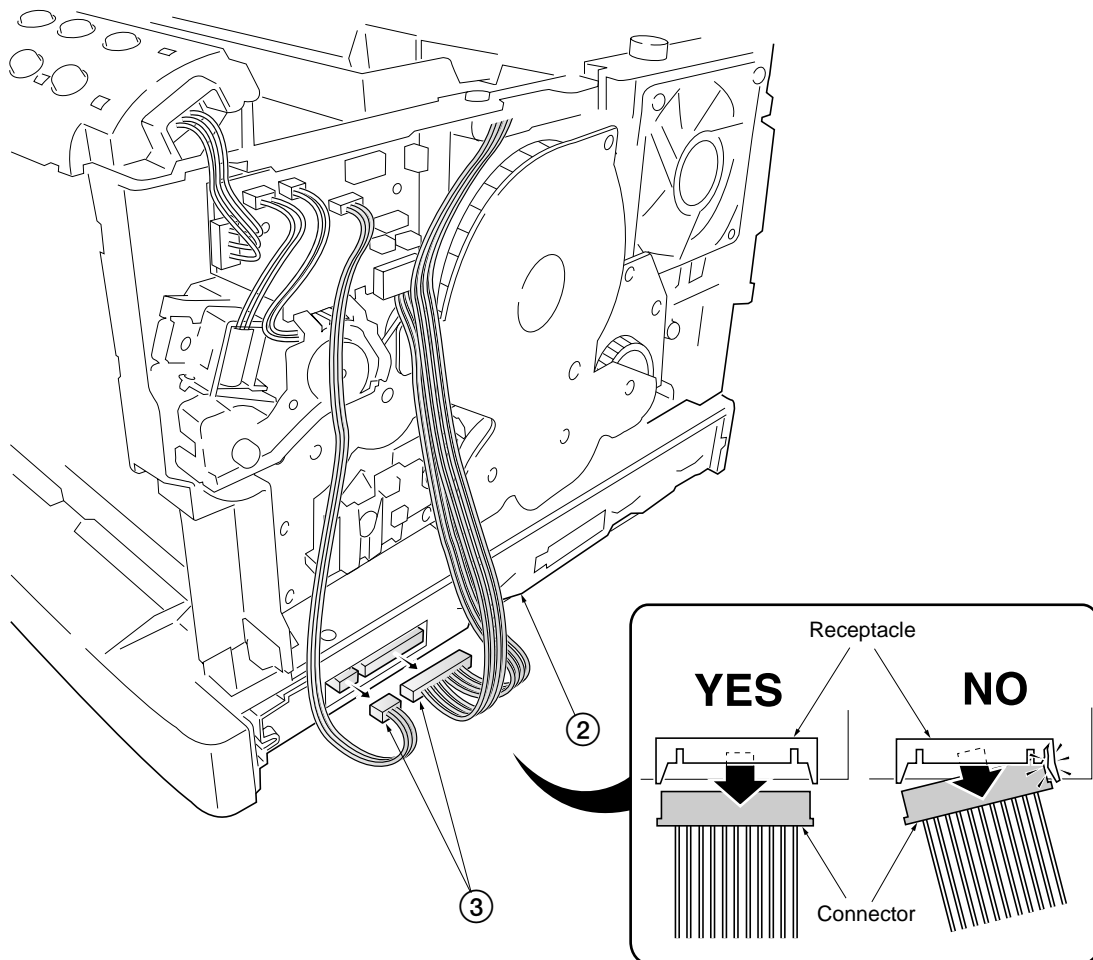

Figure 5-2-16 Removing the connectors from controller unit right side

5. Remove three screws (4).
6. Remove frame unit (5) while releasing the projections from the catches on the frame unit (5).

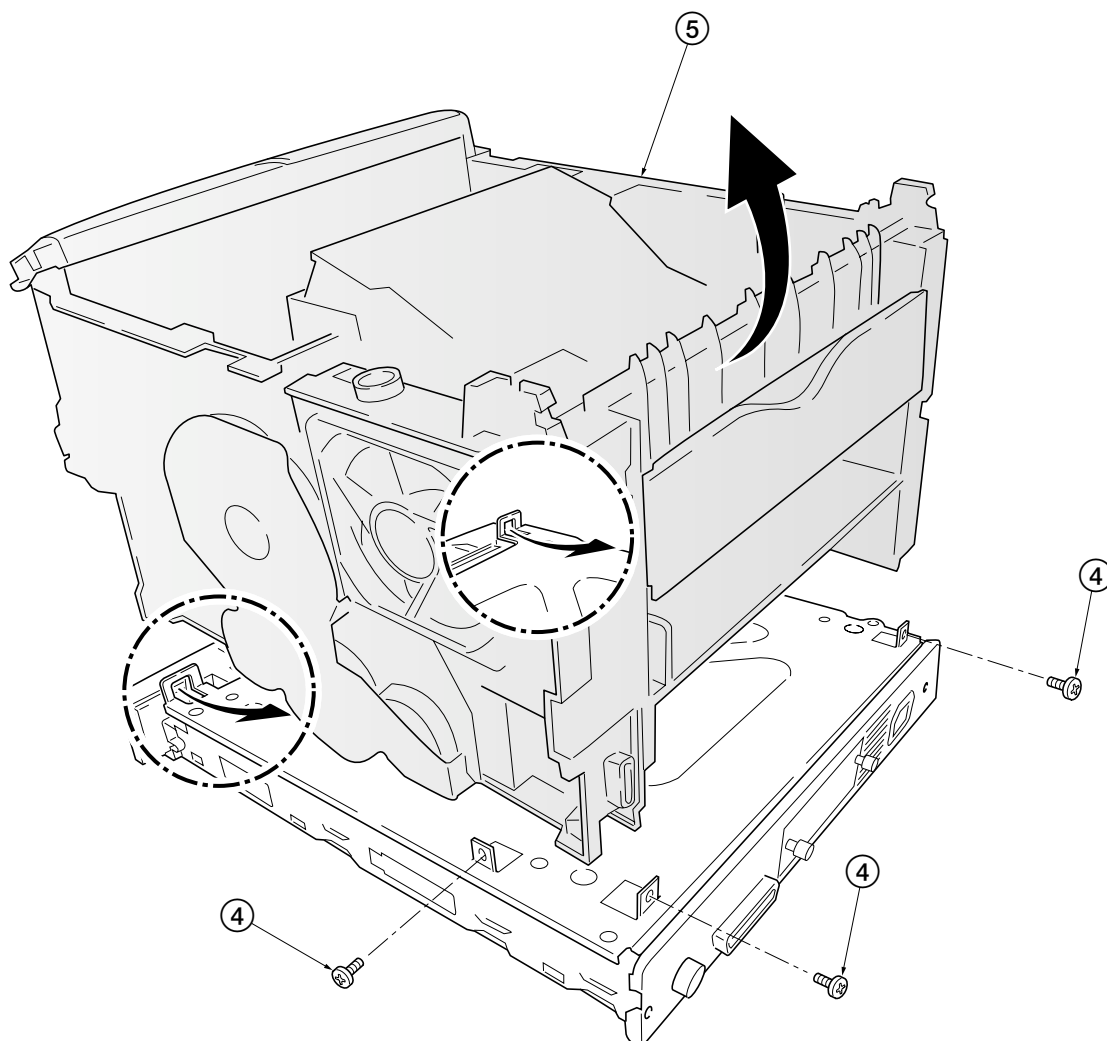

Figure 5-2-17 Removing the controller unit form the frame unit

7. Remove two screws (6).
8. Remove the main board (7).
9. Remove four screws (8).
10. Remove the controller unit lid (9) from the controller unit (2).

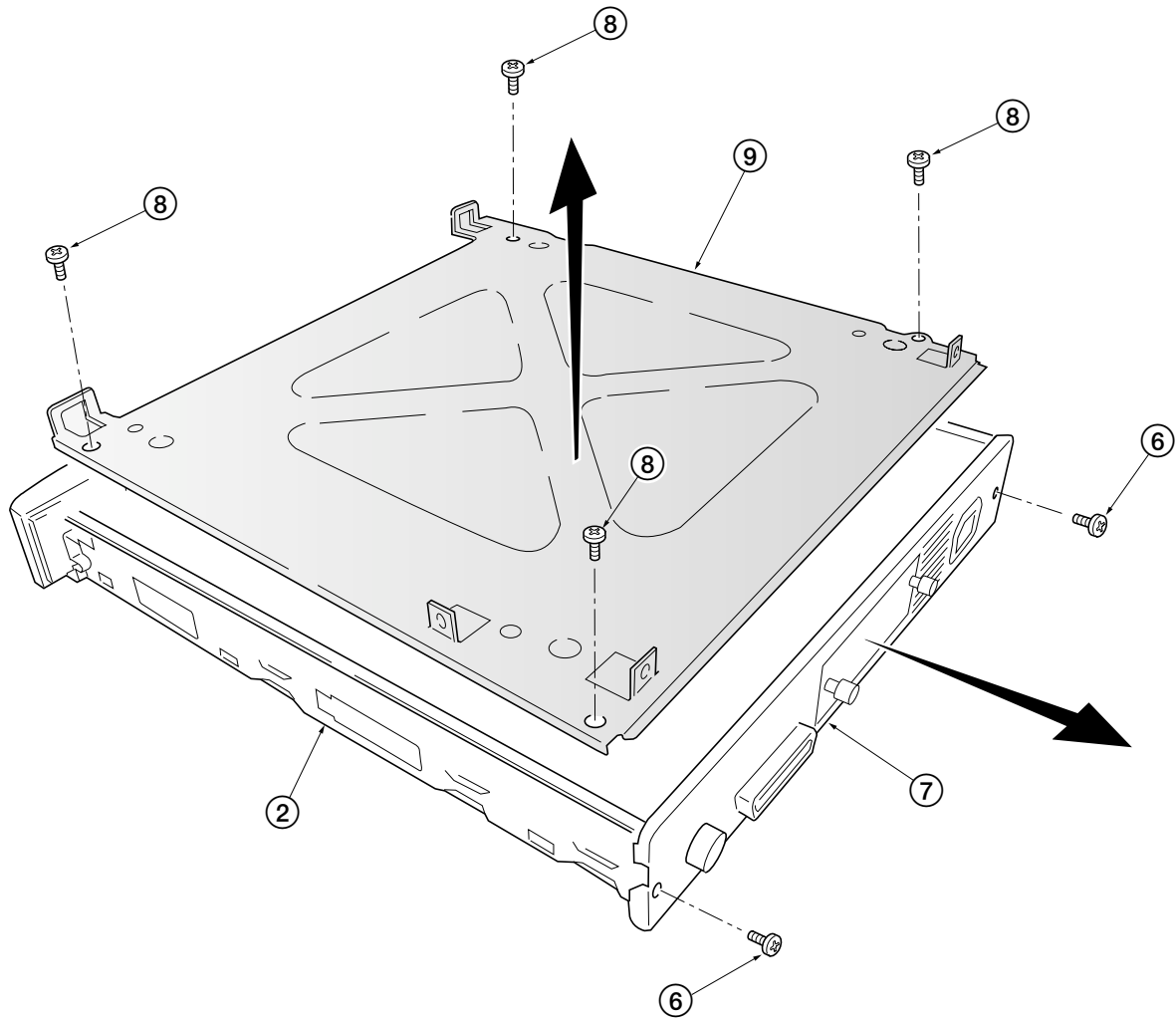

Figure 5-2-18 Opening the controller unit

(2) Removing the engine board and power supply unit

1. Remove and open the controller unit. See pages 5-18.
2. Remove two connectors ① from the engine board ②.
3. Remove five screws ③.
4. Remove the engine board ②.

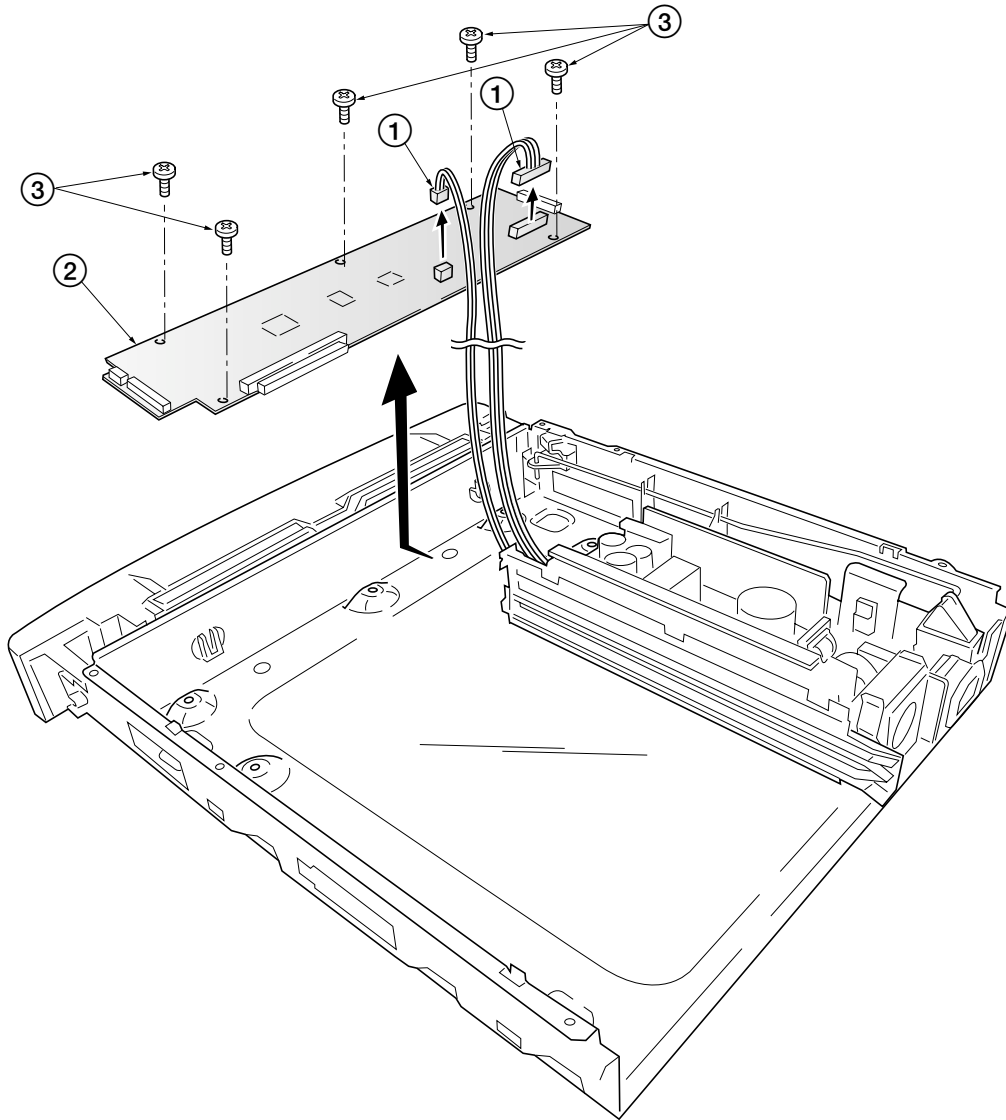

Figure 5-2-19 Removing the engine board

5. Remove the power switch rod (4).
6. Remove three screws (5), grounding wire terminal (6), and lock washer (7).
7. Remove the power supply unit (8) from the power supply unit cover (9).

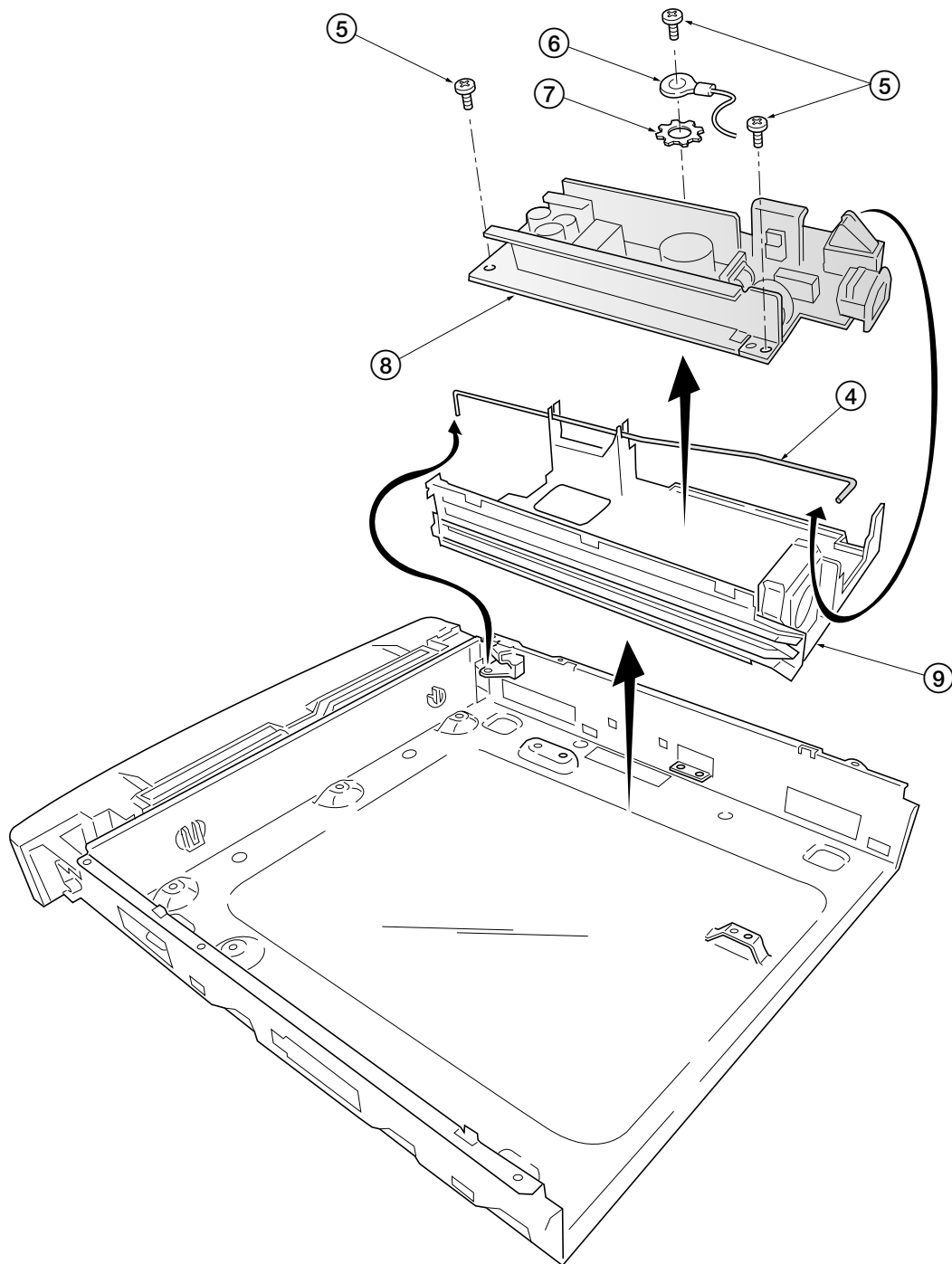

Figure 5-2-20 Removing the power supply unit

(3) Removing the main board

CAUTION



Before removing the main board, the memory card must be removed first. However, do not remove the memory card while power is on. If the memory card is removed (or inserted) while the printer is on, damage could result in the printer's electronics as well as the memory card.

1. Turn the power switch off.
2. Remove the memory card that may be inserted in the memory card slot ① at the left side of the printer.
3. Remove two screws ②.
4. Pull the main board ③ all the way out of the printer.

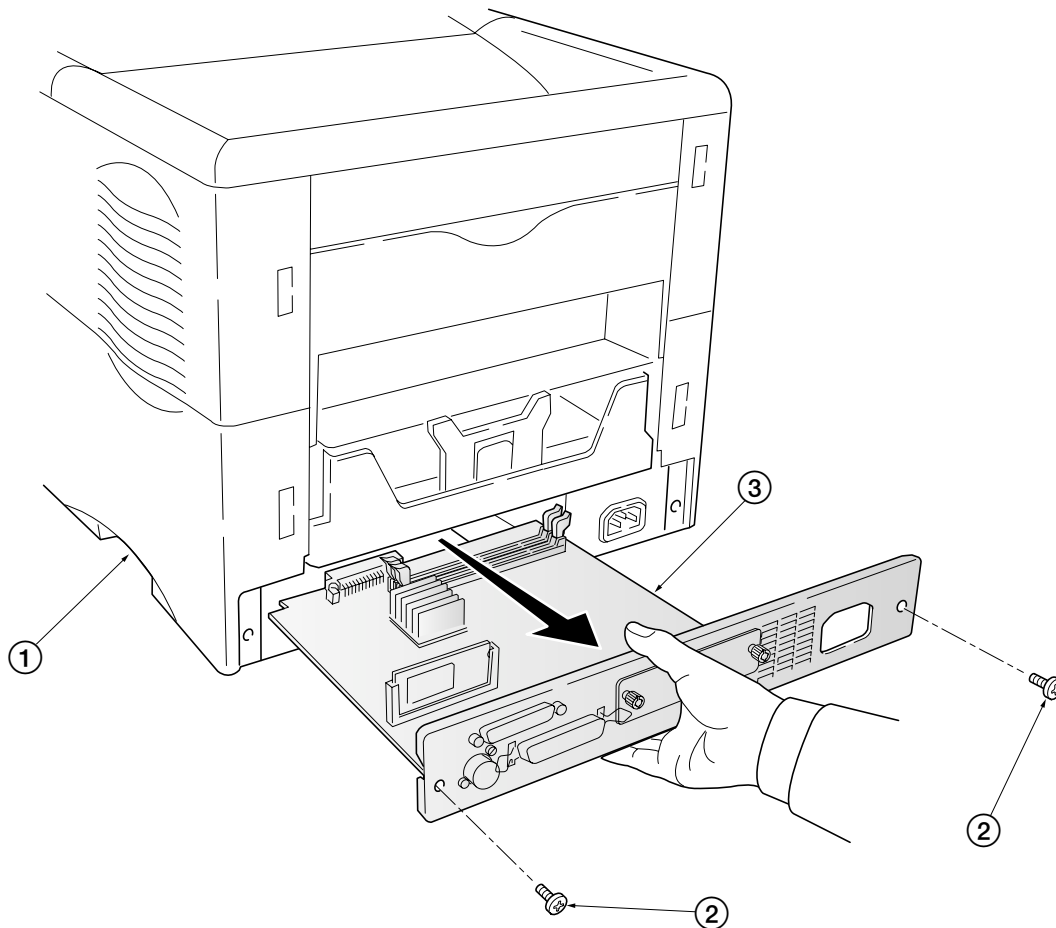

Figure 5-2-21 Removing the main board

(4) Removing the high voltage unit

- 1. Remove the top cover and left covers. See pages 5-9 and 5-11.
- 2. Remove the high voltage unit (1) while unlatching two latches (2).
- 3. Remove two connectors (3), from the high voltage unit. (1).

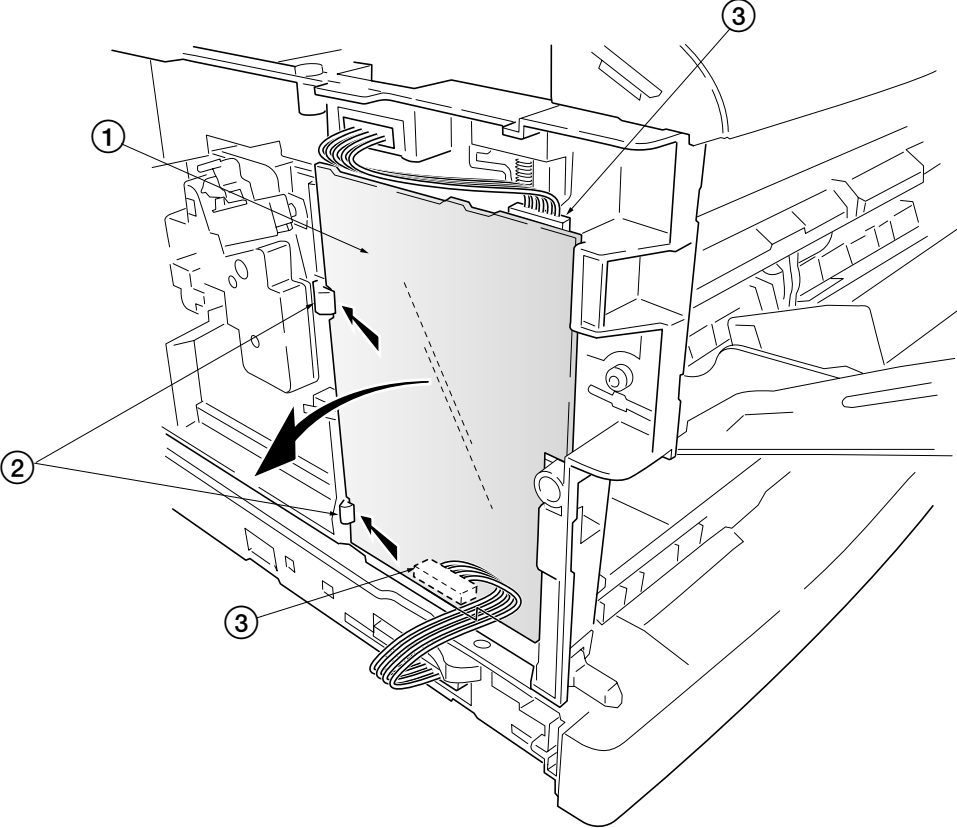

Figure 5-2-22 Removing the high voltage unit

(5) Removing the sensor board

CAUTION Draw the connector straight to remove. If you draw the connector while it is slanted, the receptacle may be damaged.

1. Remove the drum unit. See page 5-12.
2. Remove the high voltage unit. See previous page.
3. Remove two connectors ①.
4. Remove the high voltage unit cover ②.
5. Remove the sensor board ③ while unlatching two latches ④.

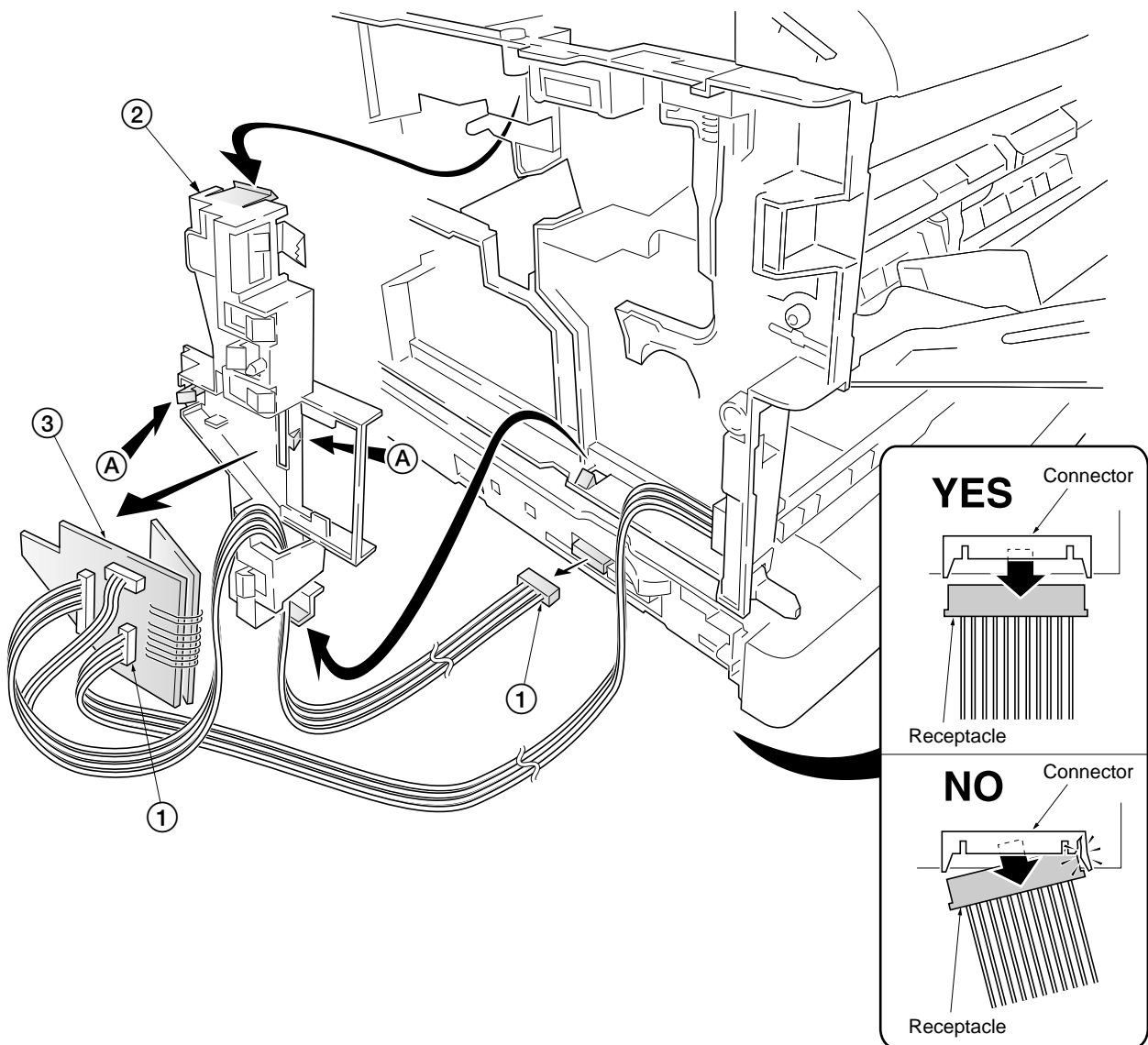

Figure 5-2-23 Removing the sensor board

5-2-10 Removing the drive unit and main motor

CAUTION Draw the connector straight to remove. If you draw the connector while it is slanted, the receptacle may be damaged.

1. Remove the paper cassette and the feed unit. See page 5-6.
2. Remove the top cover/face-down output tray. See page 5-9.
3. Remove the left and right covers. See pages 5-10 and 5-11.
4. Remove two connectors (1).
5. Remove three connectors (2) of the drive unit (3).
6. Remove five screws (4) and the ground wire terminal (5).
7. Remove the drive unit (3) from the frame unit.

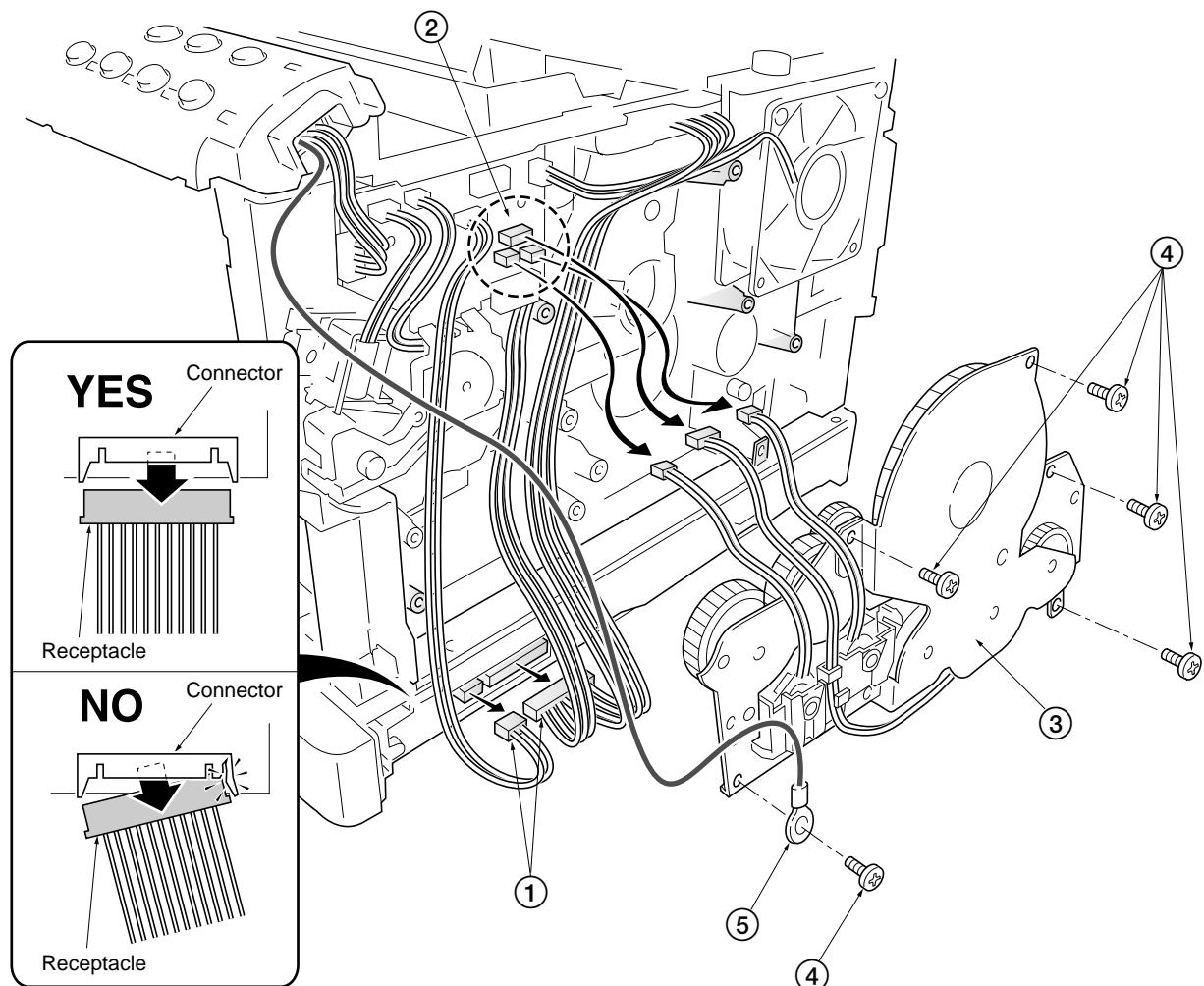

Figure 5-2-24 Removing drive unit

8. Remove four screws (6).
9. Remove the main motor (7) from the drive unit (3).

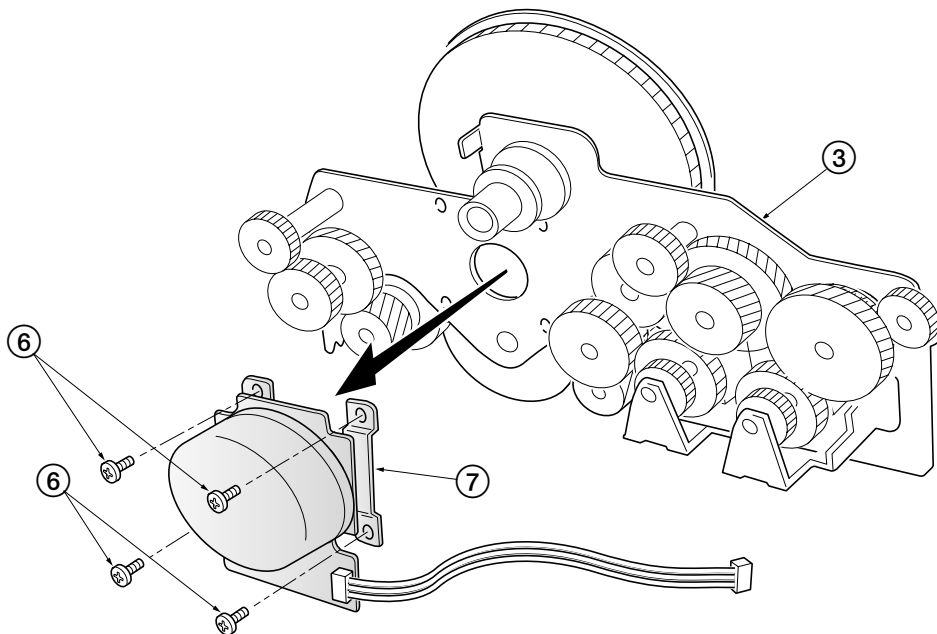

Figure 5-2-25 Removing the main motor

5-2-11 Removing and splitting the fuser unit

WARNING The fuser unit is hot after the printer was running. Wait until it cools down.



1. Remove three connectors (1).
2. Remove two screws (2).
3. Remove the fuser unit (3) from the frame unit.

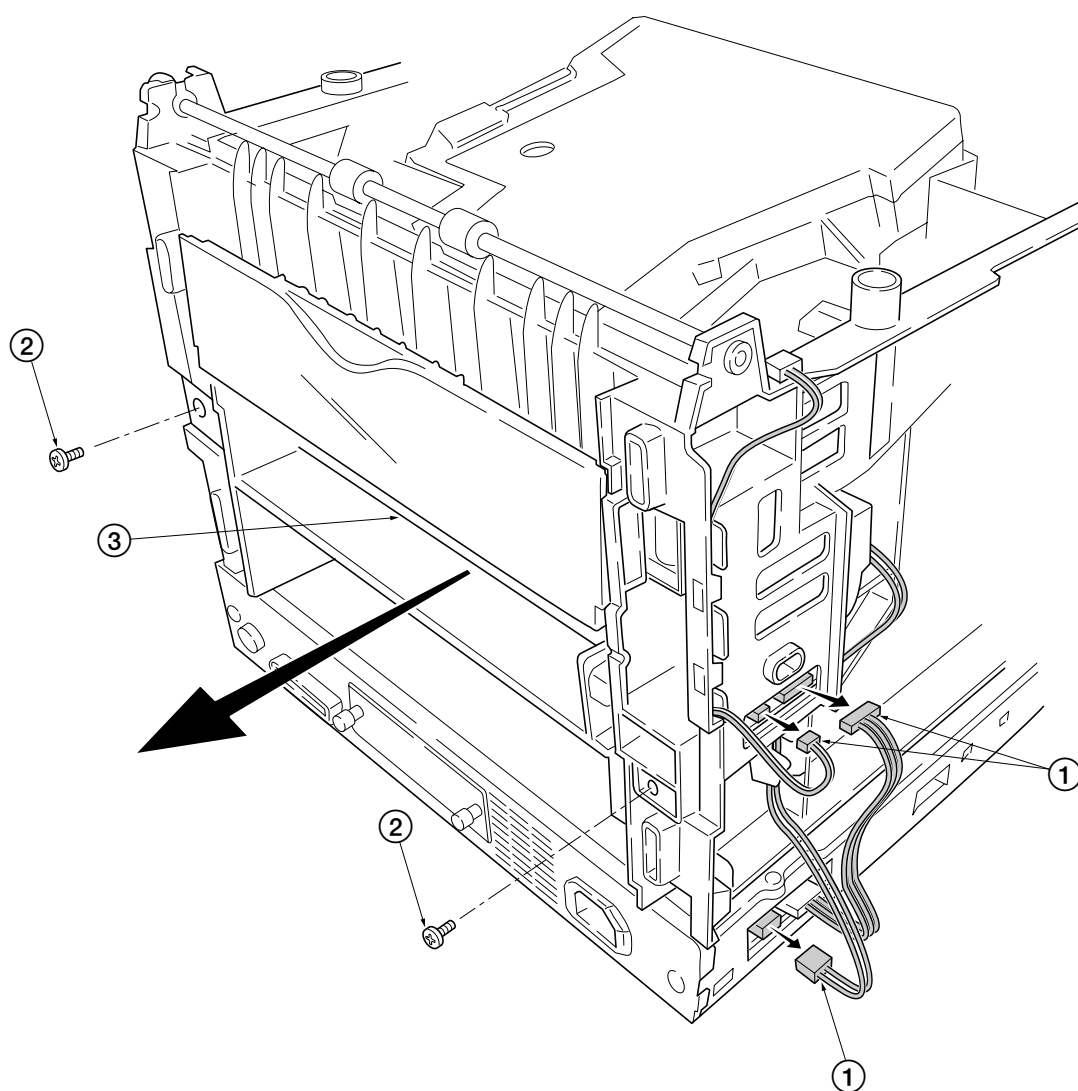

Figure 5-2-26 Removing the fuser unit

4. Remove the rear cover (4) and the spring (5).
5. Remove the solenoid actuator (6).
6. Remove the change guide (7).
7. Remove one connector (8).

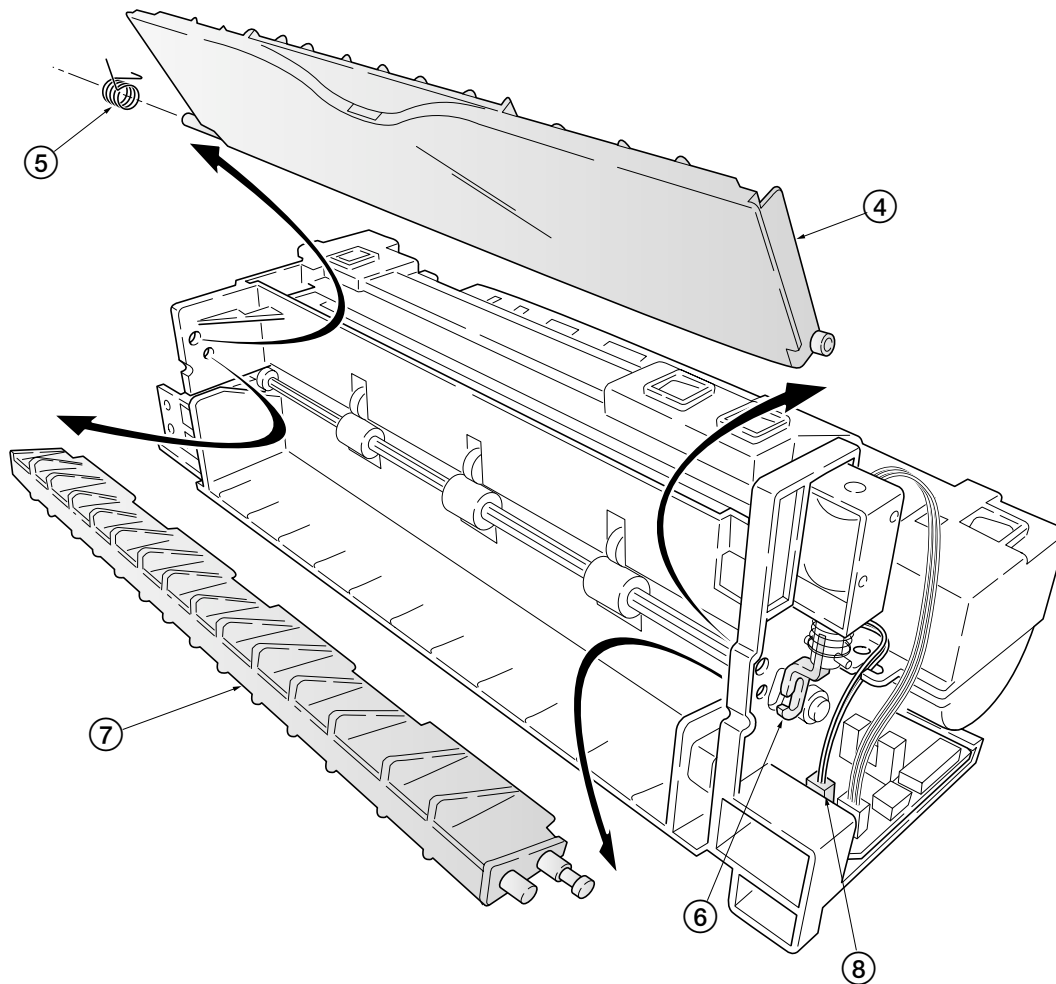

Figure 5-2-27 Removing the rear cover and change guide

8. Remove two screws (9).
9. Split the fuser unit (10).

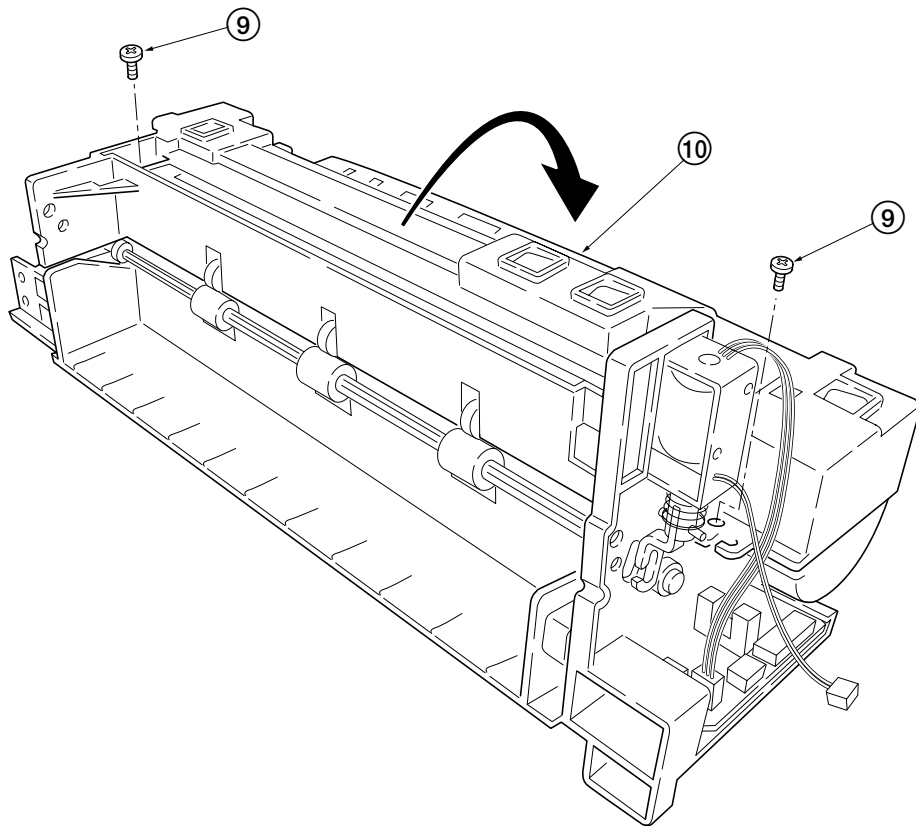

Figure 5-2-28 Splitting the fuser unit

(1) Removing the separators

WARNING The separators are extremely hot immediately after the printer was running. Allow substantial period of time until it cools down.



1. Remove and split the fuser unit. See page 5-29.
2. Remove the upper exit guide (1) while unlatching three latches (2).
3. Remove the exit pulley (3).
4. Hold the separator (4) upright and remove the separator (4) and the separator spring (5).

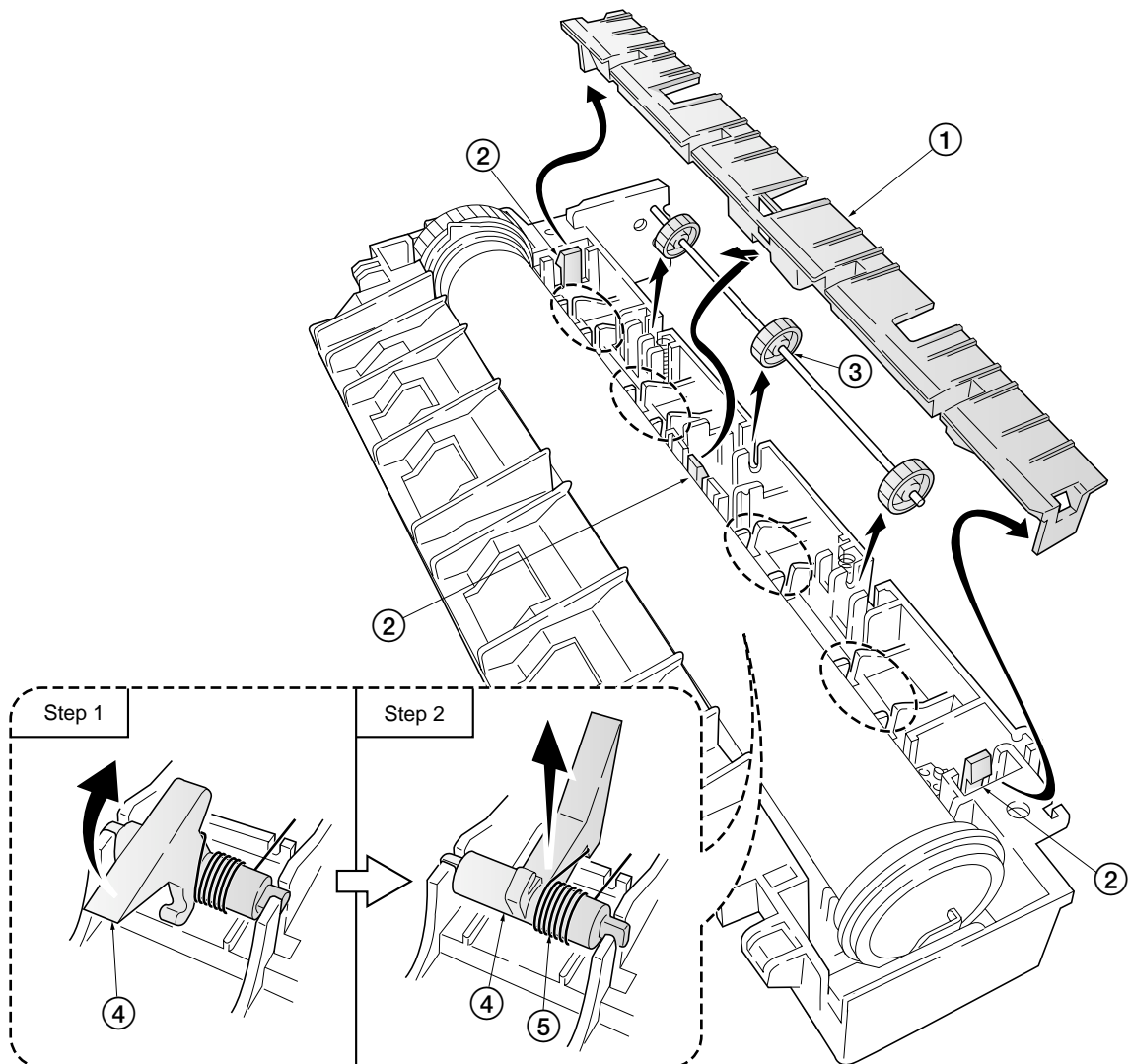

Figure 5-2-29 Removing the separators

(2) Removing the heater lamp

WARNING



The heater lamp is extremely hot immediately after the printer was running. Allow substantial period of time until it cools down.

CAUTION



The heater lamps are fragile. Use extreme care when handling not to drop or break.

Do not directly touch on the heater lamp. Finger prints on the heater lamp's outer surface can prevent proper fusing of toner on paper. When holding the heater lamp, hold the ceramic parts of heater lamp at both ends.

When refitting the heater lamp, direct the wattage making side facing the gear side.

1. Remove and split the fuser unit. See page 5-29.
2. Remove the lamp support (1).
3. Remove one screw (2) then remove the lamp holder (3).
4. Remove the heater lamp (4) from the heat roller (5).

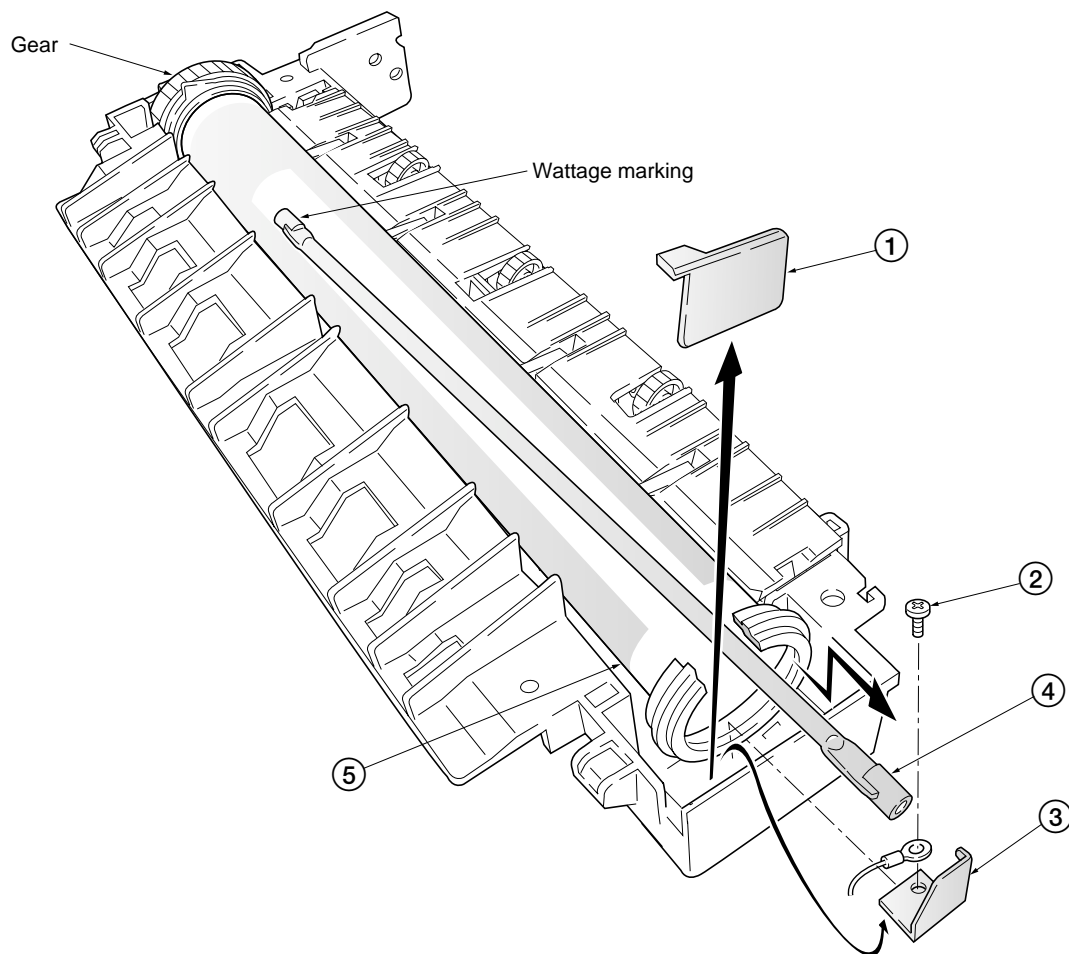

Figure 5-2-30 Removing the heater lamp

(3) Removing the heat roller

WARNING



The heat roller is extremely hot immediately after the printer was running. Allow a substantial period of time until it cools down.

1. Remove and split the fuser unit. See page 5-29.
2. Remove the heater lamp. See the previous page.
3. Remove the separators. See page 5-32.
4. Pull up both heat R bush ① and heat L bush ② at the same time.
5. Remove heat gear Z36^{*1}/Z26^{*2} ③, heat R bush ①, and heat L bush ② from the heat roller ④.

*1: FS-1800/1800N *2: FS-3800/3800N

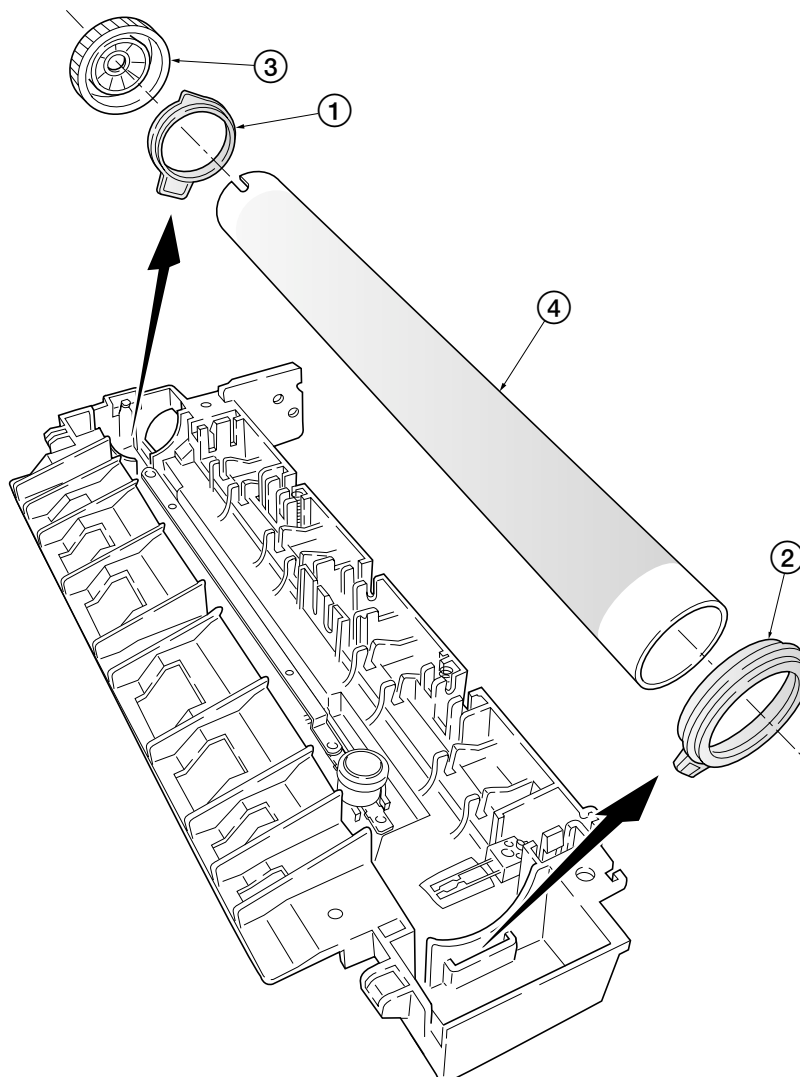

Figure 5-2-31 Removing the heat roller

(4) Removing the thermistor and the thermal cutout

1. Remove and split the fuser unit. See page 5-29.
2. Remove the heater lamp. See page 5-33.
3. Remove the heat roller. See previous page.
4. Remove one screw (1).
5. Remove the thermistor (2).
6. Remove two screws (3) and then remove cord plate (4).
7. Remove one screw (5) and the heater wire terminal (6).
8. Remove the thermal cutout (7).

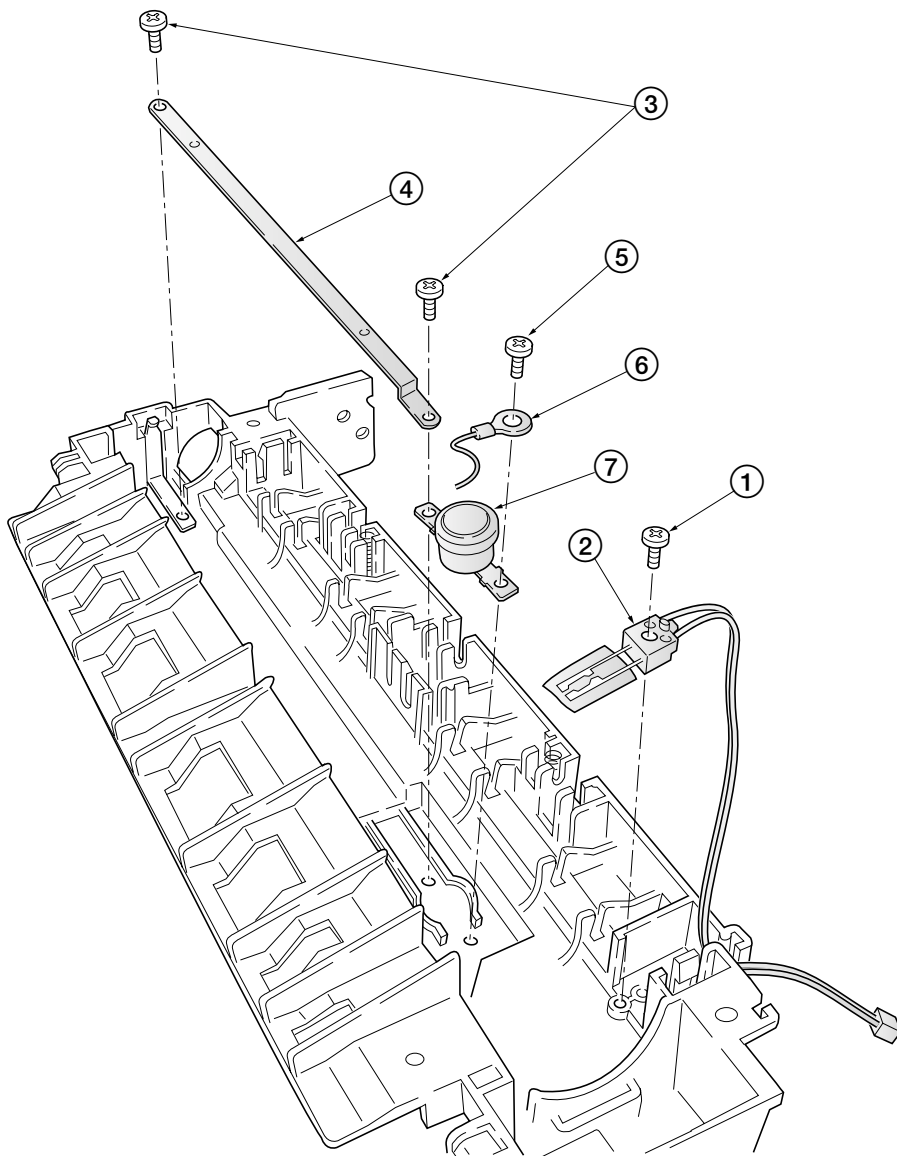

Figure 5-2-32 Removing the thermistor and thermal cutout

(5) Removing the press roller

WARNING The press roller is extremely hot immediately after the printer was running. Allow substantial period of time until it cools down.



1. Remove and split the fuser unit. See page 5-29.
2. Remove the press roller ① from the fuser unit ②.

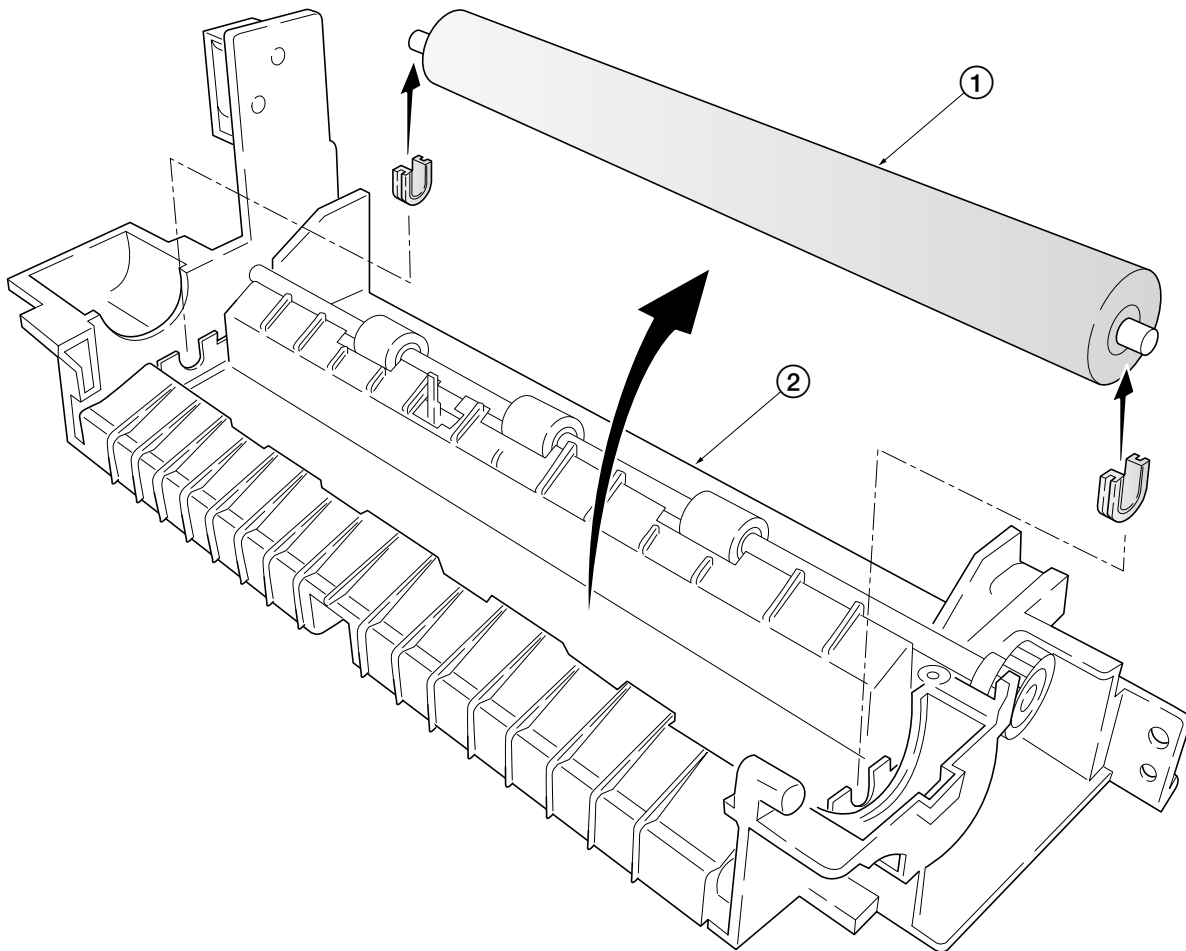
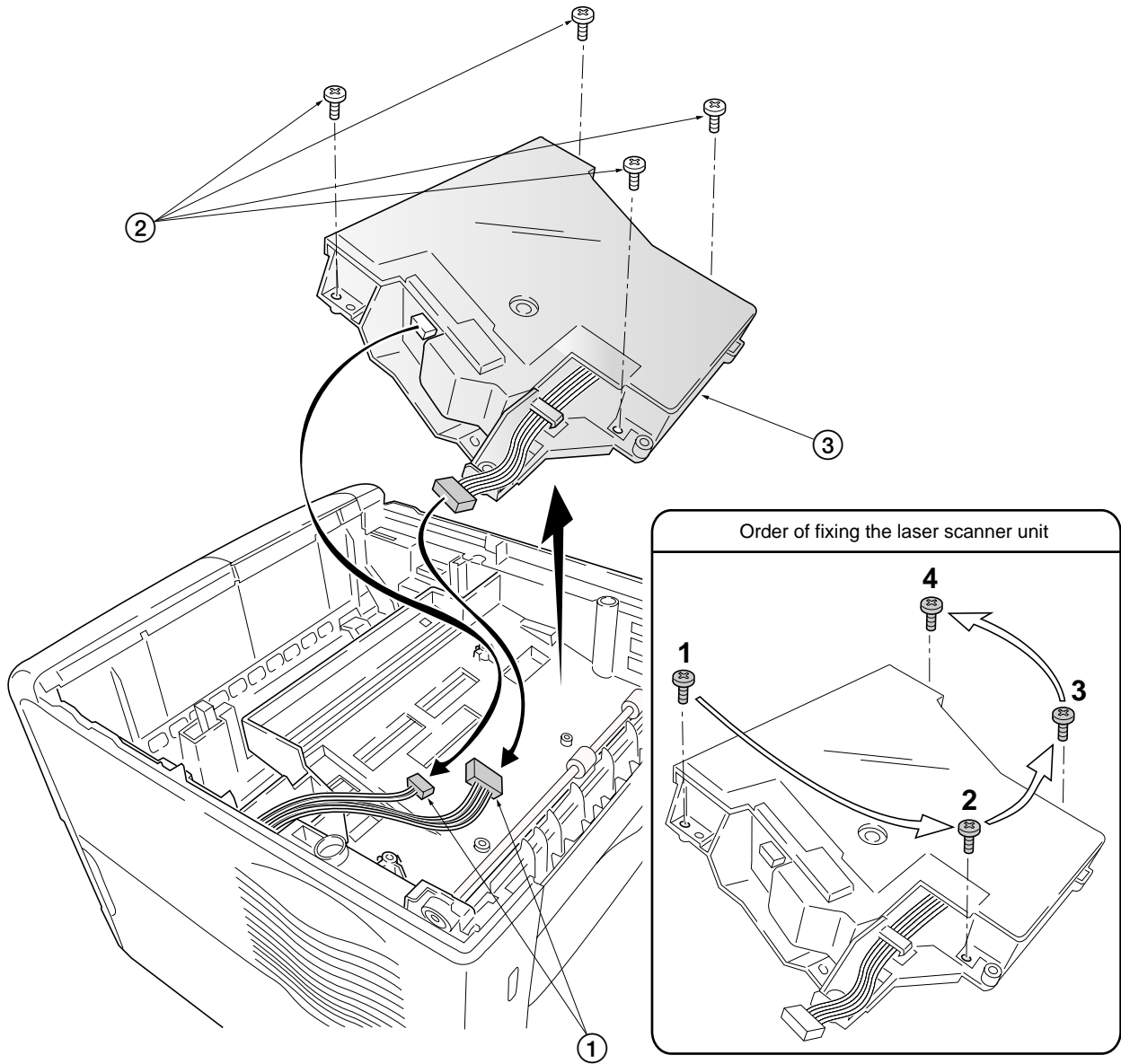

Figure 5-2-33 Removing the press roller

5-2-12 Removing the laser scanner unit

1. Remove the top cover/face-down output tray. See pages 5-9.
2. Remove two connectors (1).
3. Remove four screws (2).
4. Remove the laser scanner unit (3) from the frame unit.



CAUTION When refitting the laser scanner unit, fix the four screws in the order indicated above.

Figure 5-2-34 Removing the laser scanner unit

Chapter 6 **T r o u b l e s h o o t i n g**

Chapter 6 Contents



6-1 Troubleshooting	6-4
6-1-1 General error handling	6-4
(1) Maintenance messages	6-4
(2) Error messages	6-7
6-1-2 Diagnostic (Service error messages)	6-11
(1) A0 —Zero cross signal error	6-12
(2) A2 —Abnormal high temperature error	6-12
(3) B2 —Option paper feeder PF-60 (Top) paper feed motor error	6-13
(4) B3 —Option paper feeder PF-60 (Middle) paper feed motor error	6-13
(5) B4 —Option paper feeder PF-60 (Bottom) paper feed motor error	6-13
(6) C0 —Option paper feeder PF-60 communication error	6-14
(7) C1 —Option duplexer DU-60 communication error	6-14
(8) C2 —Option duplexer DU-60 side registration error	6-14
(9) C4 —Option sorter SO-60 communication error	6-15
(10) CE —Option bulk paper feeder PF-8E motor error	6-16
(11) CF —Option bulk paper stacker HS-8E motor error	6-16
(12) E0 —Communication error	6-16
(13) E1 —Main motor error	6-17
(14) E2 —Laser scanner unit (Polygon motor) error	6-18
(15) E3 —Laser scanner unit (Pin photo diode sensor) error	6-19
(16) E4 —Fuser unit error	6-20
(17) E5 —Eraser lamp error	6-21
(18) E9 —Toner motor error	6-22
(19) ED —Flash ROM error	6-23
(20) F0 —LCD controller board error	6-23
(21) F1 —System DIMM [board] error	6-23
(22) F2 —Main or expanded memory error	6-24
(23) F3 —General failure	6-24
(24) 99 —Toner refreshing mode error	6-24
6-1-3 Other problems	6-25
(1) False “Paper feed unit Open”	6-25
(2) False “Top cover Open”	6-25
(3) False “Side cover Open”	6-26
(4) Defective waste toner bottle detecting	6-26
(5) Defective paper jam detecting	6-27
(6) Defective paper gauge sensing	6-27
(7) Defective paper size detecting	6-27
(8) Defective message displaying (LCD)	6-28
(9) Defective face up/down solenoid operating	6-29

6-1-4 Circuit board terminal voltages	6-30
(1) Engine board	6-30
6-1-5 Assignment of circuit board connector pins	6-36
6-1-6 Print quality problems	6-37
(1) Completely blank printout	6-38
(2) All-black printout	6-39
(3) Dropouts	6-40
(4) Black dots	6-41
(5) Black horizontal streaks	6-41
(6) Black vertical streaks	6-42
(7) Unsharpness	6-43
(8) Gray background	6-44
(9) Dirt on the top edge or back of the paper	6-45
(10) Undulated printing at the left edge (scanning start position)	6-46
Repetitive defects gauge	6-47
6-1-7 Correcting a paper jam	6-48
(1) Jam in the rear cover	6-48
(2) Jam inside the printer	6-49

6-1 Troubleshooting

6-1-1 General error handling





(1) Maintenance messages

Message	Corrective action
Add paper (paper source)	The paper has run out. Supply paper according to the paper source displayed (paper cassette, MP tray, or option paper feeder). Messages indicating the printer status (Ready, Please wait Processing *, Waiting, and FormFeed Time Out *) are displayed alternately. * These messages will not appear if the number of copies is set to 2 or more.
Check waste toner bottle 	The waste toner bottle is not installed. Replace the old waste toner bottle with the new one which is included in the TK-60/TK-60E toner kit. The message will also be shown if the waste toner bottle has become full. The waste toner bottle should be replaced when the message display eventually shows Toner low TK-60. See section <i>Toner container replacement</i> on page 3-5.
Clean printer Press GO	Clean the inside of the printer, according to section 3-1-3 <i>Cleaning the printer</i> on page 3-8. This message will be displayed when replacing the toner container after the message Replace toner TK-60 has been displayed. After cleaning the inside of the printer, press the GO key and the printer will be ready for printing. If Auto Continue is set to On, printing will be automatically resumed after a preset period of time.
Duplexer rear cover open	Open the option duplexer rear cover, then close tightly.
Face-down tray paper full 	The face-down output tray has become full (approximately 250 pages). Remove all printed pages from the face-down output tray. When the printer senses that the face-down output tray is empty again, it will continue printing into the face-down output tray.

 : Alarm buzzer sounds when an error occurs. Press the CANCEL key to stop the alarm buzzer.

Message	Corrective action
<p>Load Cassette # (paper size)/(paper type)*</p> <p>*(paper size) and (paper type) are displayed flashing alternately.</p> <p style="text-align: right;">🔊</p>	<p>Paper whose size matches the size embedded in a print job is empty. Set paper into the paper source as displayed on the operator panel, and press the GO key to restart printing. The paper source number (#) is only displayed when there is an optional paper feeder installed. If you want to print from an alternative paper source press the \wedge key or \vee key to display <i>Use alternative?</i> and you can change to another paper source. Further, you can change the paper source by pressing the GO key.</p> <p>After selecting a paper source and pressing the MENU key, <i>Paper handling ></i> appears. By pressing the > key, the paper type setting menu appears. After setting the correct paper type, press the ENTER key and printing starts.</p>
<p>Load MP tray (paper size)/(paper type)</p> <p>*(paper size) and (paper type) are displayed flashing alternately.</p>	<p>There is no paper cassette (paper size and paper type) that matches the size embedded in a print job. Printing is done from the MP tray. Set paper into the MP tray that matches the paper size and type shown on the display and press the GO key to restart printing. If you want to print from an alternative paper source, press the \wedge or \vee key to display <i>Use alternative?</i> and you can change to another paper source. Further, you can change the paper source by pressing the GO key.</p> <p>After selecting a paper source and pressing the MENU key, <i>Paper Handling ></i> appears. By pressing the > key, the paper type setting menu appears. After setting the correct paper type, press the ENTER key and printing starts.</p>
<p>Missing duplex drawer</p>	<p>The duplex drawer is either not installed or incorrectly inserted. Insert the duplex drawer securely.</p>
<p>Opt. Stacker unit rear cover open</p>	<p>Open the sorter rear cover, then close tightly.</p>
<p>Option interface Error</p>	<p>A failure has occurred with the (option) network interface card. Check the (option) network interface card installed on the printer.</p>

🔊 : Alarm buzzer sounds when an error occurs. Press the **CANCEL** key to stop the alarm buzzer.

Message	Corrective action
Option tray ## paper full 	The sorter tray indicated by # is now full. Remove the paper from the tray.
Paper feed unit Open	Open the paper feed unit, then close tightly.
Paper jam ##### 	Open the top cover or the paper feed unit and correct the paper jam (or paper mis-feeding in the cassette). The location of the paper jam is also indicated in place of the # 's. On-line help messages which are useful for correcting the paper jam will be displayed by pressing the  key. See section 6-1-7 <i>Correcting a Paper Jam</i> on page 6-48.
Remove paper option tray ## 	There is still paper in the option sorter's tray indicated by # when the power was turned on or the sorter's mode was switched. Remove all the paper inside the sorter.
Replace toner Clean printer 	Replace the toner container using a new toner kit. The printer does not operate when this message is displayed. See section <i>Toner container replacement</i> on page 3-5.
Side cover Open	Open the side cover, then close tightly.
Toner low TK-60	Replace the toner container using a new toner kit. See section <i>Toner container replacement</i> on page 3-5.
Top cover Open	Open the top cover, then close tightly.
Warning image adapt	Printing job cannot be done in current resolution because there is not enough memory. Try adding more memory or change resolution.
Warning Low memory	The printer memory is running low due to the number of fonts and macros downloaded. Print a status page to see how much user memory is left, and try deleting unnecessary fonts and macros.

 : Alarm buzzer sounds when an error occurs. Press the CANCEL key to stop the alarm buzzer.

(2) Error messages

Message	Corrective action
Call service personAn:0123456	(Refer to section 6-1-2 <i>Diagnostic (Service error messages)</i> on page 6-11.)
Call service personBn:0123456	(Refer to section 6-1-2 <i>Diagnostic (Service error messages)</i> on page 6-11.)
Call service personCn:0123456	(Refer to section 6-1-2 <i>Diagnostic (Service error messages)</i> on page 6-11.)
Call service personDn:0123456	(Refer to section 6-1-2 <i>Diagnostic (Service error messages)</i> on page 6-11.)
Call service personEn:0123456	(Refer to section 6-1-2 <i>Diagnostic (Service error messages)</i> on page 6-11.)
Call service personFn	(Refer to section 6-1-2 <i>Diagnostic (Service error messages)</i> on page 6-11.)
Call service person99	(Refer to section 6-1-2 <i>Diagnostic (Service error messages)</i> on page 6-11.)
File not found Press GO	VMB: A VMB tray that was specified for output does not contain any jobs, or the VMB tray is not being used. Confirm the VMB tray. If <code>Auto Continue</code> is set to On, printing will be automatically resumed after a preset period of time. Refer to printer's <i>User's Manual</i> .
Format error Memory Card	This message appears when the printer is in the ready state and the memory card (CompactFlash) is not formatted, and therefore cannot be read or written. Refer to printer's <i>User's Manual</i> .
Format error Hard disk	Initialization (formatting) of the hard disk is required. Initialize the hard disk (Microdrive). Refer to printer's <i>User's Manual</i> .
Hard disk error## Press GO	Look at the error code given in place of ## and refer to the corresponding description given below. 01 : Hard disk (Microdrive) format error. If this error recurs even if the power has been turned off and then on, reformat the hard disk. 02 : The disk system is not installed. Recheck the requirements for using the system and the devices. 04 : There is no available hard disk (Microdrive) space. Delete unnecessary files, etc., in order to free up space. 05 : The specified file does not exist in the hard disk (Microdrive). 06 : There is no memory available to the hard disk (Microdrive) system. Increase the available memory.

 : Alarm buzzer sounds when an error occurs. Press the CANCEL key to stop the alarm buzzer.

Message	Corrective action
Hard disk error## Press GO	10 : Formatting is not possible because host data is being spooled on the hard disk (Microdrive). Wait until the hard disk is ready, and then format. 85 : VMB; Alias error (The alias setting was lost, or the VMB tray corresponding to the alias does not exist.) Set alias again. 97 : Code job; The number of permanent code job reached the limit value, and no more can be saved. Either delete some unnecessary jobs, etc., or increase the limit. 99 : A print job for the specified ID does not exist in the hard disk (Microdrive).
I/F occupied	This message is displayed when you attempt to use the printer's operator panel to change the environmental settings on the interface from which data are presently being received.
ID error	The ID entered for a private job, or a stored job is not correct. Check the ID that is set using the printer driver.
Insert the same memory card	You have inserted a wrong memory card (CompactFlash) when the Insert again message was displayed. Remove the wrong memory card from the printer's memory card slot and insert the correct memory card. The printer again reads it from the beginning of the data.
KPDL Error ## Press GO	PostScript error has occurred and current print processing cannot continue. To print out an error report, display >Print KPDL errs from the menu selection system, and select On. Press the GO key to resume printing. You can abandon printing by the CANCEL key. If Auto Continue is set to On, printing will be automatically resumed after a preset period of time. Refer to printer's <i>User's Manual</i> .
Memory card err Insert again	The memory card (CompactFlash) is accidentally removed from the printer's memory card slot during reading. If you continue reading the memory card, insert the same memory card into the slot again. The printer again reads it from the beginning of the data. Note: We recommend that you follow the reading procedure from the beginning to ensure correct reading of the memory card.

🔊: Alarm buzzer sounds when an error occurs. Press the CANCEL key to stop the alarm buzzer.

Message	Corrective action
Memory overflow Press GO	The total amount of data received by the printer exceeds the printer's internal memory. Try adding more memory (expansion DIMM). Press the GO key to resume printing. You can abandon printing by the CANCEL key. If Auto Continue is set to On, printing will be automatically resumed after a preset period of time. Refer to printer's <i>User's Manual</i> .
MemoryCard err## Press GO	This message appears when an error occurred during access to the memory card (CompactFlash) using the PRESCRIBE 2e RWER command or from the printer's operator panel. Look at the error code given in place of ## and refer to the corresponding description given below: 01 : The memory card (CompactFlash) does not meet the requirement. This memory card cannot be used by this printer. Insert a memory card which complies with the requirements. (See section 1-1-2 <i>Available option memory/device</i> on page 1-6.) 02 : The memory card is not installed. Check the requirements for using the memory card. 04 : The capacity of the memory card is insufficient. Clean up files. 05 : Specified file not found on the memory card. 06 : Insufficient printer memory to support a memory card. Expand printer memory.
Paper path error	There is no cassette in the feeder, or the cassette is not inserted properly. When two or more option feeders are installed and the lowest one is selected, the same message will appear if any of the upper feeder cassettes and the printer cassette is improperly installed.
Print overrun Press GO	The data transferred to the printer was too complex to print on a page. Press the GO key to resume printing. (The page may break in some pages.) You can abandon printing by the CANCEL key. Note: After this message has been displayed, Page protect mode will be On. To maintain optimum use of memory during printing, display >Page protect from the operator panel, and re-select Auto. Refer to printer's <i>User's Manual</i> . If Auto Continue is set to On, printing will be automatically resumed after a preset period of time. Refer to printer's <i>User's Manual</i> .

 : Alarm buzzer sounds when an error occurs. Press the **CANCEL** key to stop the alarm buzzer.

Message	Corrective action
RAM disk error ## Press GO	Look at the error code given in place of ## and refer to the corresponding description below. 01 : Abnormal format. Try turning the power off and on again. 02 : RAM DISK mode is Off. Turn RAM DISK mode On. 04 : No disk space. Clean up files. 05 : Specified file not on disk. 06 : No insufficient printer memory to support RAM disk. Expand printer memory.
Virtual mail box fail	The storage area for the VMB is full. Purge accumulated VMB data by printing or deleting them.



: Alarm buzzer sounds when an error occurs. Press the CANCEL key to stop the alarm buzzer.

6-1-2 Diagnostic (Service error messages)

The printer does not operate when a message beginning with A to F and 99 is displayed. The message is categorized as follows:

Message	Meaning
Call service personAn:0123456	Fuser error (n=0, 2). The total number of pages printed follows. Follow the appropriate instructions provided in the following sections.
Call service personBn:0123456	Option paper feeder error (n=2 to 4). The total number of pages printed follows. This message pertains to option paper feeder PF-60. Follow the appropriate instructions provided in the following.
Call service personCn:0123456	Option equipment error (n=0 to 4, 7, E and F). The total number of pages printed follows. This message pertains to paper feeder PF-60, sorter SO-60, and duplexer DU-60. Follow the appropriate instructions provided in the follow sections.
Call service personDn	Engine firmware download error (n=0 to 3). See section <i>3-1-4 Updating the firmware</i> on page 3-15.
Call service personEn:0123456	Mechanical error (n=0 to 5, 9 and D). The total number of pages printed follows. Follow the appropriate instructions provided in the following section.
Call service personFn	Controller error (n=0 to 3). Follow the appropriate instructions provided in the following sections.
Call service person99	Toner refreshing mode error. Follow the appropriate instruction provided in the following sections.

(1) A0 —Zero cross signal error

Meaning	Suggested causes	Corrective action
The ZCROSS signal does not reach the engine board within 3 seconds after power on.	• Defective power supply unit.	Replace power supply unit. See page 5-22.
	• Defective CPU U201 on the engine board.	Replace engine board. See page 5-22.

(2) A2 —Abnomal high temperature error

Meaning	Suggested causes	Corrective action
CPU U201 detected that the HTEMP* signal (Abnormal temperature of more than approximately 220 °C) is low for more than 3 seconds.	• Defective CPU U201 or comparator U205 on the engine board.	Follow the flow chart below.
	• Defective engine board (KP-864).	
	• Defective thermistor.	
	• Defective photo coupler on the power supply unit for the heater lamp.	

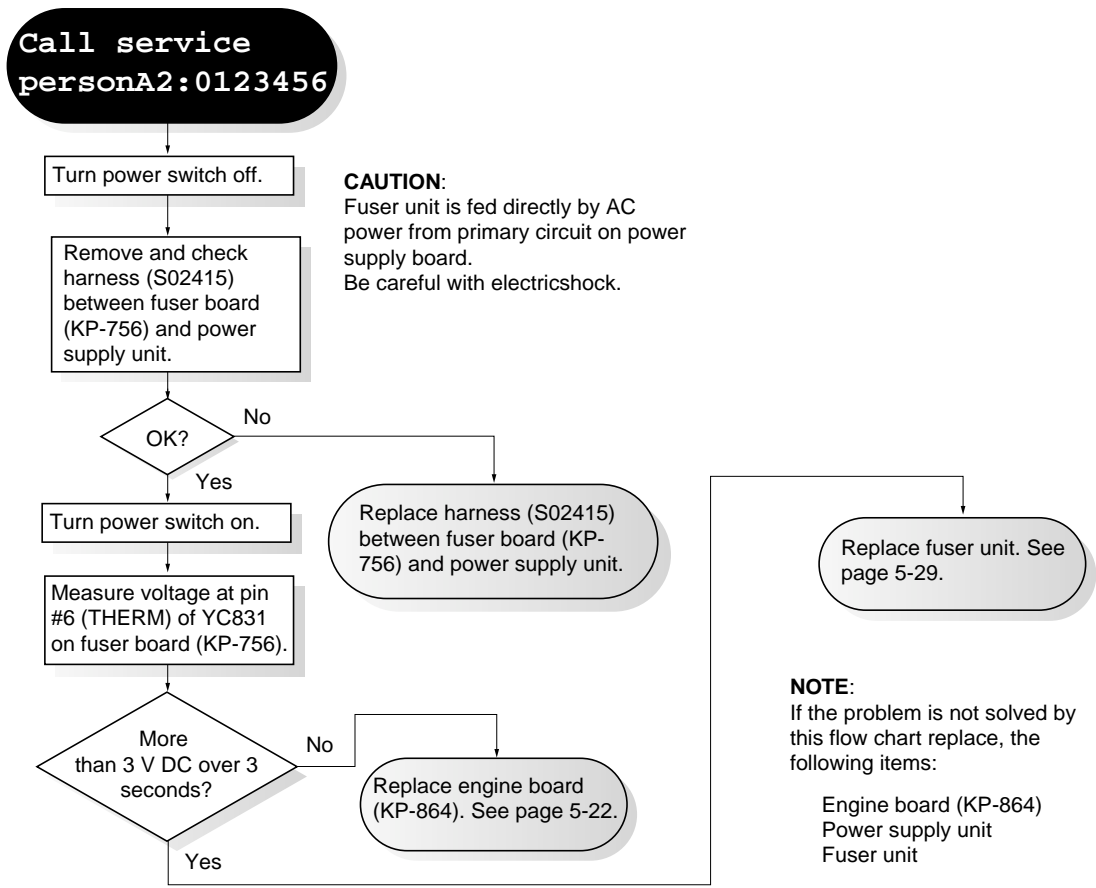

(3) B2 —Option paper feeder PF-60 (Top) paper feed motor error

Meaning	Suggested causes	Corrective action
Paper feed motor error in the top option paper feeder.	• Defective gate array U204 on the engine board (KP-864).	Replace engine board (KP-864). See page 5-22.
	• Defective harness (S02400) between engine board and option unit interface connector.	Replace harness (S02400).
	• Defective paper feeder PF-60.	Refer to option paper feeder PF-60's <i>Service Manual</i> .

(4) B3 —Option paper feeder PF-60 (Middle) paper feed motor error

Meaning	Suggested causes	Corrective action
Paper feed motor error in the middle option paper feeder.	• Defective gate array U204 on the engine board (KP-864).	Replace engine board (KP-864). See page 5-22.
	• Defective harness (S02400) between engine board and option unit interface connector.	Replace harness (S02400).
	• Defective option paper feeder PF-60.	Refer to option paper feeder PF-60's <i>Service Manual</i> .

(5) B4 —Option paper feeder PF-60 (Bottom) paper feed motor error

Meaning	Suggested causes	Corrective action
Paper feed motor error in the bottom option paper feeder.	• Defective gate array U204 on the engine board (KP-864).	Replace engine board (KP-864). See page 5-22.
	• Defective harness (S02400) between engine board and option unit interface connector.	Replace harness (S02400).
	• Defective paper feeder PF-60.	Refer to option paper feeder PF-60's <i>Service Manual</i> .

(6) C0 —Option paper feeder PF-60 communication error

Meaning	Suggested causes	Corrective action
Communication error between engine board and option paper feeder PF-60.	• Defective gate array U204 on the engine board (KP-864).	Replace engine board (KP-864). See page 5-22.
	• Blown-out fuse (F202) on the engine board.	
	• Improper installation between printer and option paper feeder.	Follow installation instruction carefully again.
	• Defective harness (S02400) between engine board and option unit interface connector.	Replace harness (S02400).
	• Improper connector insertion.	Remedy.
	• Defective option paper feeder PF-60.	Refer to option paper feeder PF-60's <i>Service Manual</i> .

*1: FS-1800/1800N *2: FS-3800/3800N

(7) C1 —Option duplexer DU-60 communication error

Meaning	Suggested causes	Corrective action
Communication error between engine board and option duplexer DU-60.	• Defective gate array U204 on the engine board (KP-864).	Replace engine board (KP-864). See page 5-22.
	• Blown-out fuse (F202) on the engine board.	
	• Improper installation between printer and option duplexers.	Follow installation instruction carefully again.
	• Defective harness (S02400) between engine board and option unit interface connector.	Replace harness (S02400).
	• Improper connector insertion.	Remedy.
	• Defective option duplexer DU-60.	Refer to option duplexer DU-60's <i>Service Manual</i> .

(8) C2 —Option duplexer DU-60 side registration error

Meaning	Suggested causes	Corrective action
Side registration home position error of option duplexer DU-60.	• Defective gate array U204 on the engine board (KP-864).	Replace engine board (KP-864). See page 5-22.
	• Improper installation between printer and option duplexers, or each option unit.	Follow installation instruction carefully again.
	• Defective harness (S02400) between engine board and option unit interface connector.	Replace harness (S02400).
	• Improper connector insertion.	Remedy.
	• Defective option duplexers DU-60.	Refer to option duplexers DU-60's <i>Service Manual</i> .

(9) C4 —Option sorter SO-60 communication error

Meaning	Suggested causes	Corrective action
Communication error between engine board and option sorter SO-60.	• Defective gate array U204 on the engine board (KP-864).	Replace engine board (KP-864). See page 5-22.
	• Blown-out fuse (F202) on the engine board.	
	• Improper installation between printer and option sorters.	Follow installation instruction carefully again.
	• Improper connector insertion.	
	• Defective main board (KP-777 ^{*1} /KP-858 ^{*2}).	Replace main board (KP-777 ^{*1} /KP-858 ^{*2}). See page 5-22.
• Defective option sorter SO-60.	Refer to option sorter SO-60's <i>Service Manual</i> .	

*1: FS-1800/1800N *2: FS-3800/3800N

(10) CE —Option bulk paper feeder PF-8E motor error

Meaning	Suggested causes	Corrective action
Motor error in the option bulk paper feeder PF-8E.	• Defective harness (S02400) between engine board and option unit interface connector.	Replace engine board (KP-864). See page 5-22.
	• Defective option bulk paper feeder.	Replace harness (S02400).

(11) CF —Option bulk paper stacker HS-8E motor error

Meaning	Suggested causes	Corrective action
Motor error in the option bulk paper stacker HS-8E.	• Defective harness (S02400) between engine board and option unit interface connector.	Replace engine board (KP-864). See page 5-22.
	• Defective option bulk paper stacker HS-8E.	Replace harness (S02400).

(12) E0 —Communication error

Meaning	Suggested causes	Corrective action
Communication between the engine board and the main board is failed.	• Defective gate array (U02) on the main board.	Replace the main board (KP-777* ¹ /KP-858* ²). See page 5-24.
	• Connector failure between the engine board (KP-864) and main board (KP-777* ¹ /KP-858* ²).	Verify connector connections.
	• Overrun in the engine system, deactivating the program flash ROM (U202) on the engine board (KP-864).	Replace the engine board (KP-864). See page 5-22.

*1: FS-1800/1800N *2: FS-3800/3800N

(13) E1 —Main motor error

Meaning	Suggested causes	Corrective action
The main motor is overloaded.	• Overcurrent in the main motor circuitry due to an excessive torque.	Follow the flow chart below.
	• Connector insertion error.	
	• Defective gate array U204 on the engine board (KP-864).	
	• Defective harness between engine board and engine relay board (KP-760).	
	• Defective harness between engine relay board (KP-760) and main motor.	

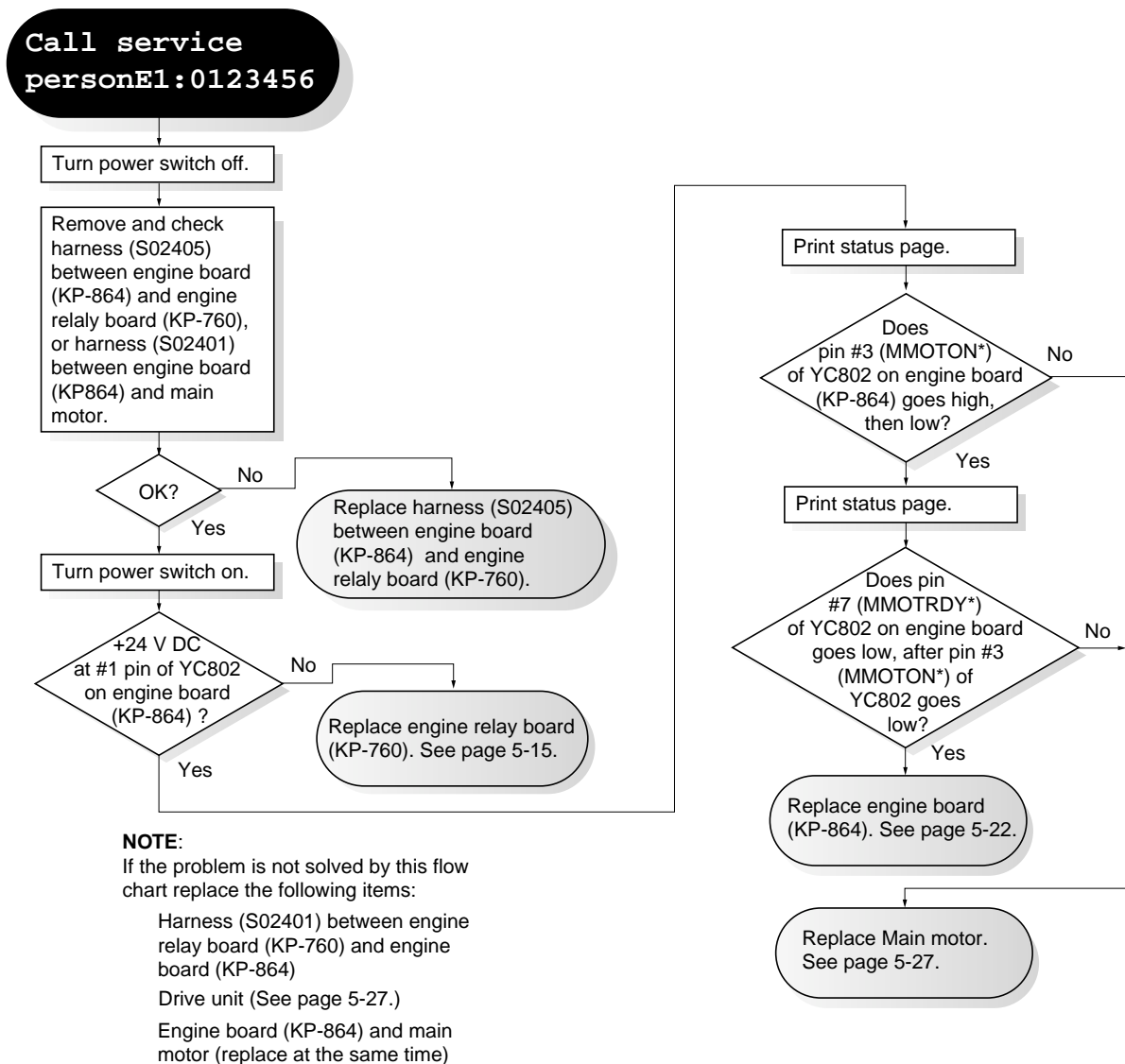

(14) E2—Laser scanner unit (Polygon motor) error

Meaning	Suggested causes	Corrective action
POLRDY* does not go low within 20 seconds after POLON* goes low (When starting) or within 16 seconds after REGPAP signal goes high (during printing).	<ul style="list-style-type: none"> Defective gate array U204 on the engine board. Defective polygon motor. Improper connector insertion. Defective harness between laser scanner unit and engine board. 	Follow the flow chart below.

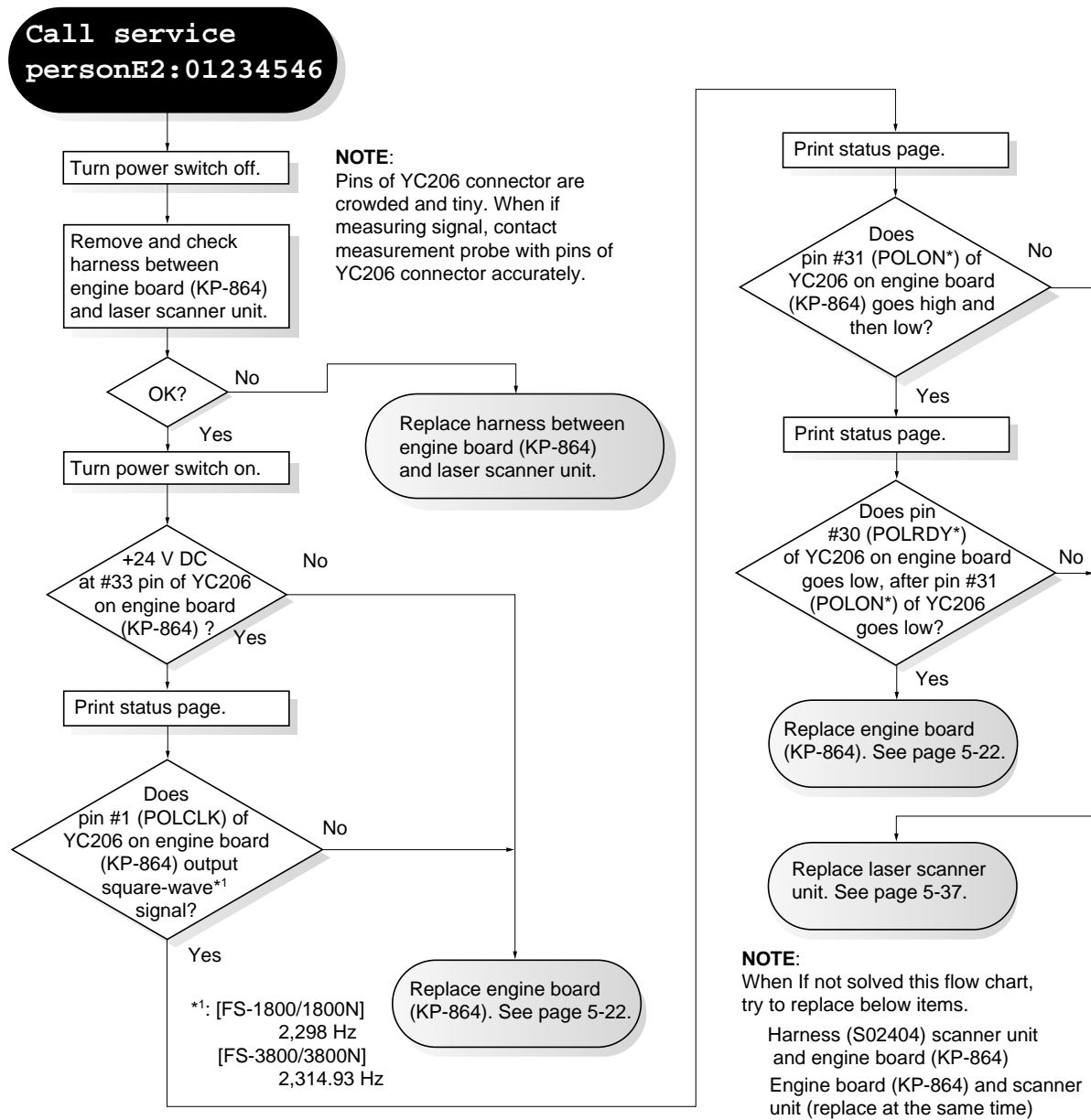

(15) E3—Laser scanner unit (Pin photo diode sensor) error

Meaning	Suggested causes	Corrective action
Laser beam detection failed. The pin photo diode sensor [board] (KP-746) does not deliver a horizontal synchronous signal (PD*).	<ul style="list-style-type: none"> No laser beam due to the laser diode defect (PD*). Soiled or defective pin photo diode sensor. Defective gate array U204 of engine board. Improper connector insertion. Defective harness between engine board and laser scanner unit. 	Follow the flow chart below.

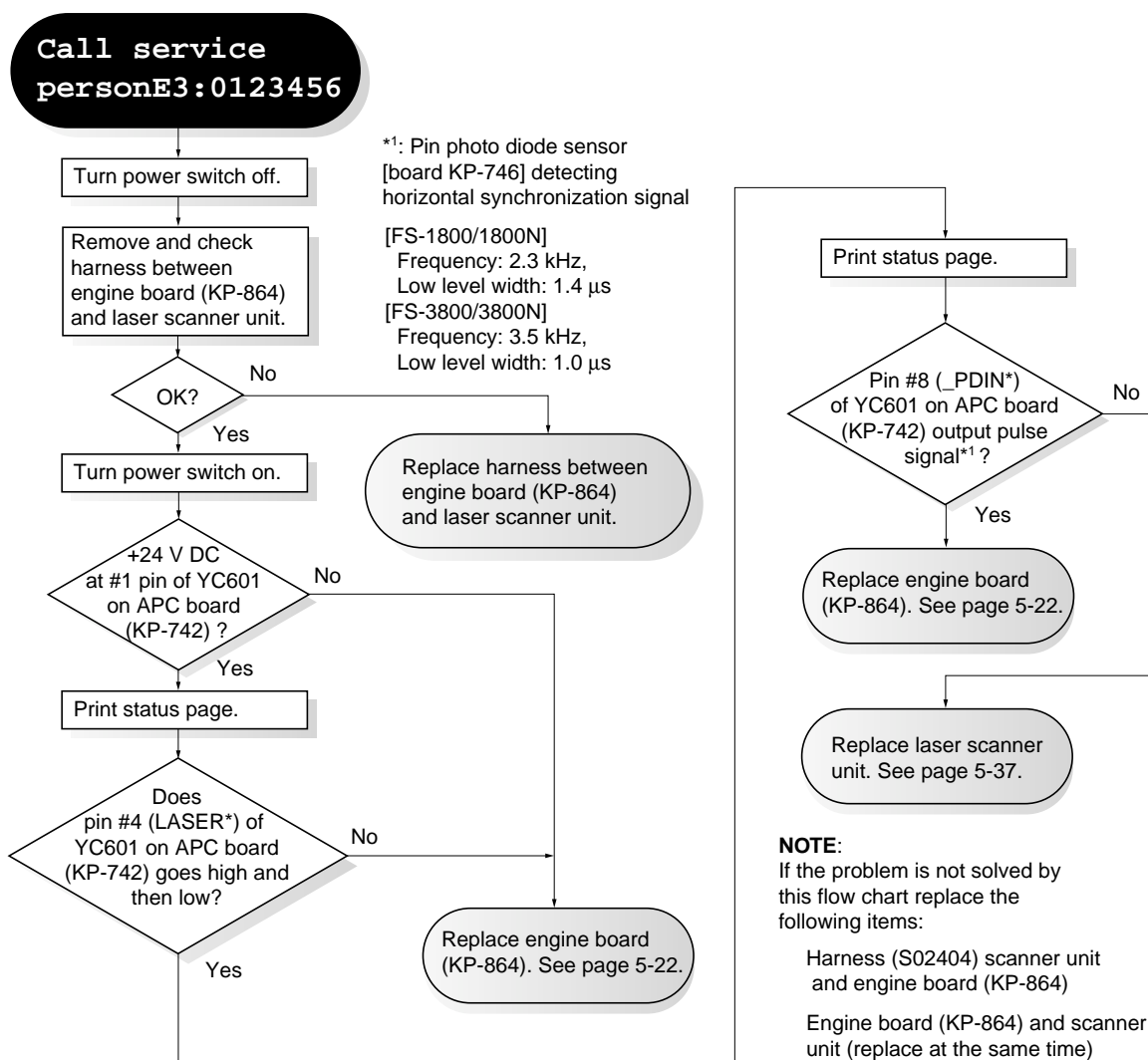

(16) E4 —Fuser unit error

Meaning	Suggested causes	Corrective action
HTEMP* remains high for longer than 4 ^{*1} /2 ^{*2} seconds since the heater lamp is on. The heater lamp continues to be turn on for longer than 60 ^{*1} /30 ^{*2} seconds.	<ul style="list-style-type: none"> • Blown-out thermistor. • Blown-out heater lamp. • Defective CPU U201 or comparator U205 on the engine board. • Improper connector insertion. • Defective power supply unit. • Defective harness between fuser unit and power supply unit. 	Follow the flow chart below.

*1: FS-1800/1800N *2: FS-3800/3800N

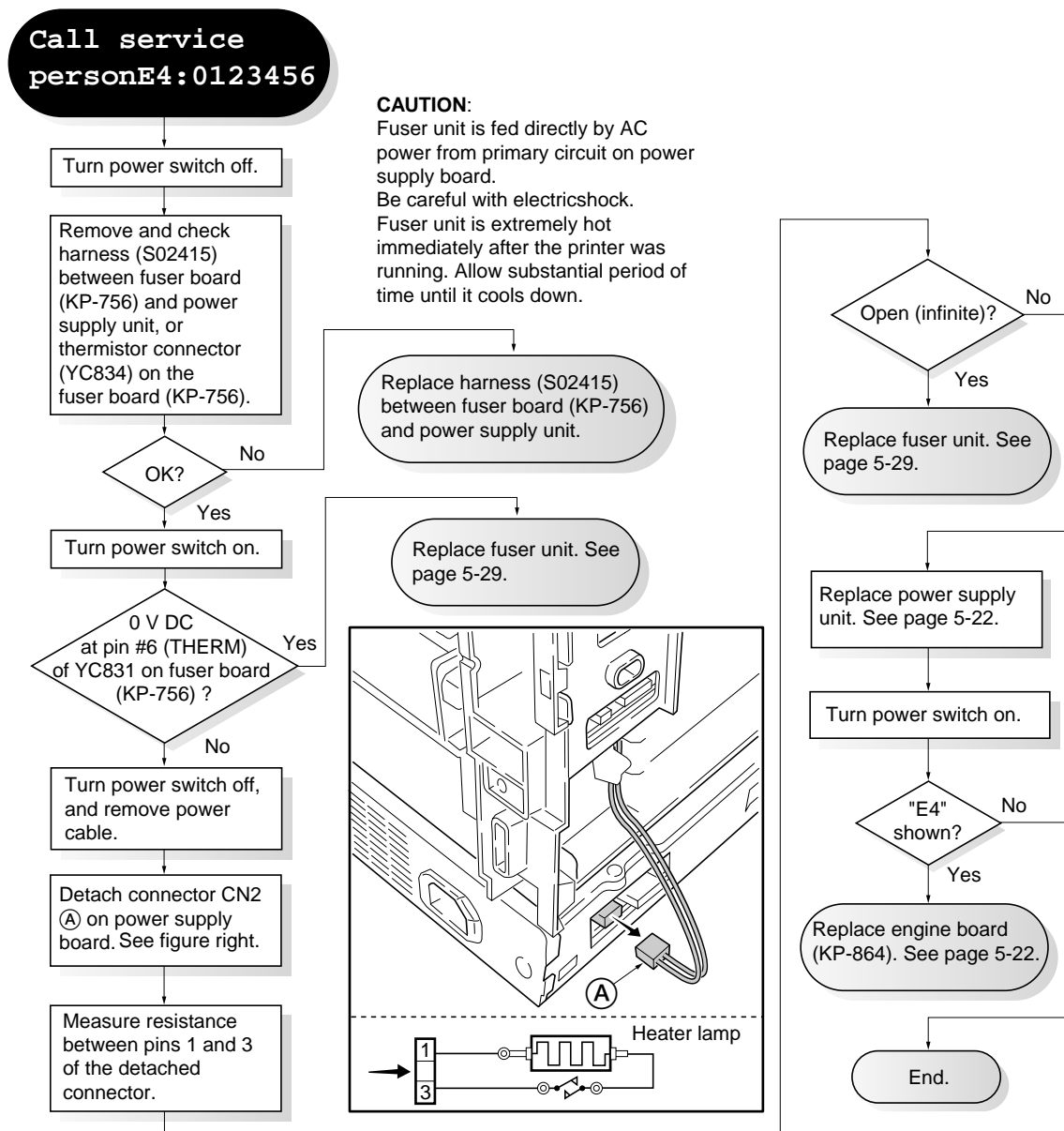

(17) E5—Eraser lamp error

Meaning	Suggested causes	Corrective action
The ERADEAD* signal (delivered from the eraser lamp blown-out detection circuit on the engine board) goes low continuously more than 1 second, while eraser lamp is on.	<ul style="list-style-type: none"> Blown-out eraser lamp [board KP-762]. Defective CPU U201 on the engine board. Improper connector insertion to the eraser lamp [board KP-762]. 	Follow the flow chart below.

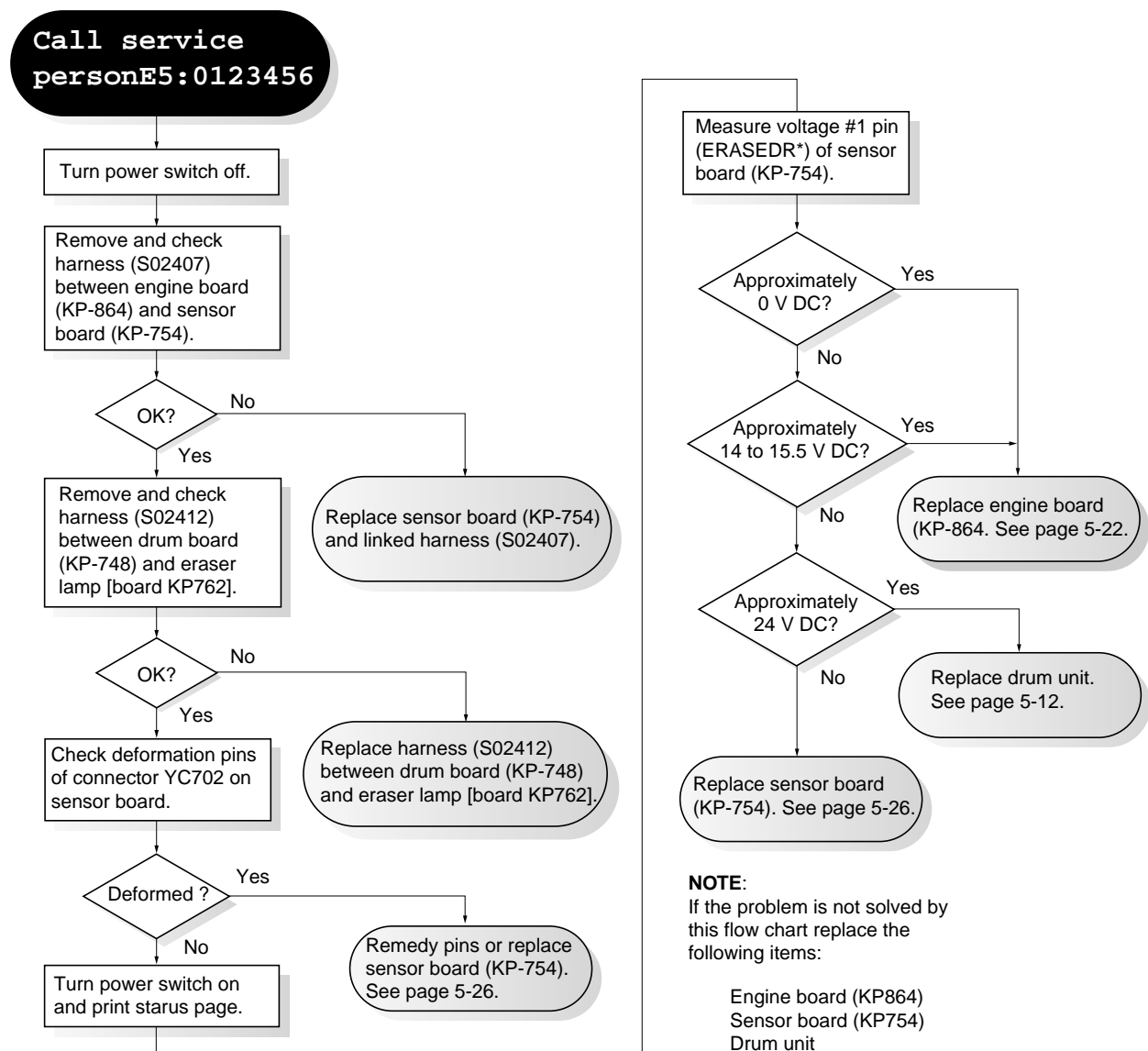

(18) E9 —Toner motor error

Meaning	Suggested causes	Corrective action
Toner motor is overloaded. TNMOC is detected by sampling every other 100 ms in 2 seconds since the main and toner motors are activated following the	<ul style="list-style-type: none"> • Overcurrent in the toner motor circuitry due to an excessive torque, caused by hardened toner. 	Follow the flow chart below.
Replace toner	<ul style="list-style-type: none"> • Defective gate array U204 on the engine board. 	
Clean printer message after	<ul style="list-style-type: none"> • Improper connector insertion. 	
the Toner low	<ul style="list-style-type: none"> • Defective harness between developer and high voltage unit. 	
TK-60 is detected.	<ul style="list-style-type: none"> • Defective harness between high voltage unit and engine board. 	

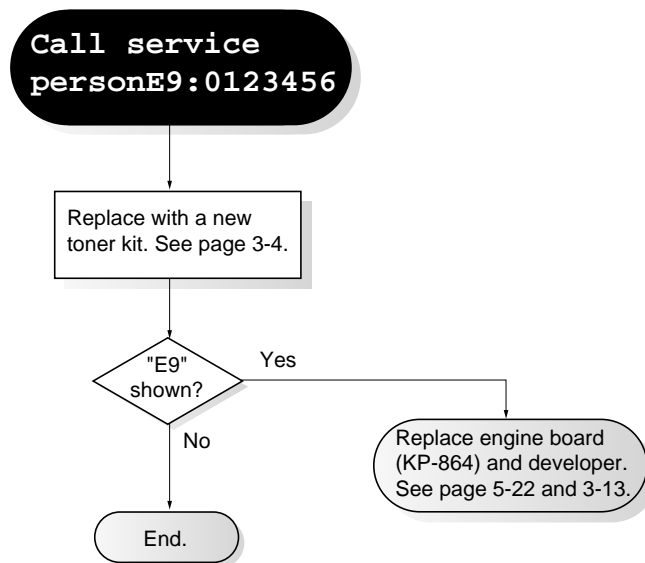

NOTE:

If the problem is not solved by this flow chart, replace the following items:

- High voltage unit
- Harness (S02416) [Between developer and high voltage unit]
- Harness (S02416) [Between engine board and high voltage unit]

(19) ED —Flash ROM error

Meaning	Suggested causes	Corrective action
CPU U201 of engine board could not write data failed to flash ROM U202. Write sequence to flash ROM is not successful. Verify error. (Written data does not match the original data.)	<ul style="list-style-type: none"> Defective CPU U201 or gate array U204 or flash ROM U202 on the engine board (KP-864). 	Replace engine board (KP-864).

(20) F0 —LCD controller board error

Meaning	Suggested causes	Corrective action
Communication is failed between the LCD controller board (KP-738) and the main board.	<ul style="list-style-type: none"> Defective system DIMM [board KP-710^{*1}/KP-689^{*2}]. 	Replace system DIMM [board KP-710 ^{*1} /KP-689 ^{*2}] or main board (KP-777 ^{*1} /KP-858 ^{*2}).
	<ul style="list-style-type: none"> Defective main board (KP-777^{*1}/KP-858^{*2}). 	Replace LCD controller board (KP-738).
	<ul style="list-style-type: none"> LCD controller board (KP-738). 	

*1 : FS-1800/1800N *2 : FS-3800/3800N

(21) F1 —System DIMM [board] error

Meaning	Suggested causes	Corrective action
Checksum failed with system DIMM [board KP-710 ^{*1} /KP-689 ^{*2}] on the main board.	<ul style="list-style-type: none"> Defective system DIMM [board KP-710^{*1}/KP-689^{*2}]. 	Replace system DIMM [board KP-710 ^{*1} /KP-689 ^{*2}] or main board (KP-777 ^{*1} /KP-858 ^{*2}).
	<ul style="list-style-type: none"> Improper system DIMM [board KP-710^{*1}/KP-689^{*2}] insertion to system DIMM slot on the main board (KP-777^{*1}/KP-858^{*2}). 	Reinsert the system DIMM [board KP-710 ^{*1} /KP-689 ^{*2}].

*1 : FS-1800/1800N *2 : FS-3800/3800N

(22) F2 —Main or expanded memory error

Meaning	Suggested causes	Corrective action
Checksum failed with main memory (RAM) on the main board or expanded memory (DIMM).	• Defective system main memory (RAM) on the main board (KP-777* ¹ /KP-858* ²).	Replace main board (KP-777* ¹ /KP-858* ²).
	• Defective main board (KP-777* ¹ /KP-858* ²).	Replace expanding
	• Defective expanding memory (DIMM) on the main board (KP-777* ¹ /KP-858* ²).	memory (DIMM).

*¹ : FS-1800/1800N *² : FS-3800/3800N

(23) F3 —General failure

Meaning	Suggested causes	Corrective action
Miscellaneous failure with the main board, other than F0, F1 and F2, above.	• Defective main board (KP-777* ¹ /KP-858* ²).	Replace main board (KP-777* ¹ /KP-858* ²).

*¹ : FS-1800/1800N *² : FS-3800/3800N

(24) 99 —Toner refreshing mode error

Meaning	Suggested causes	Corrective action
Toner refreshing mode error.	• Defective high voltage unit.	Replace high voltage unit. See page 5-25. Refer to section <i>Toner refreshing mode</i> on page 3-22.

6-1-3 Other problems

(1) False "Paper feed unit Open"

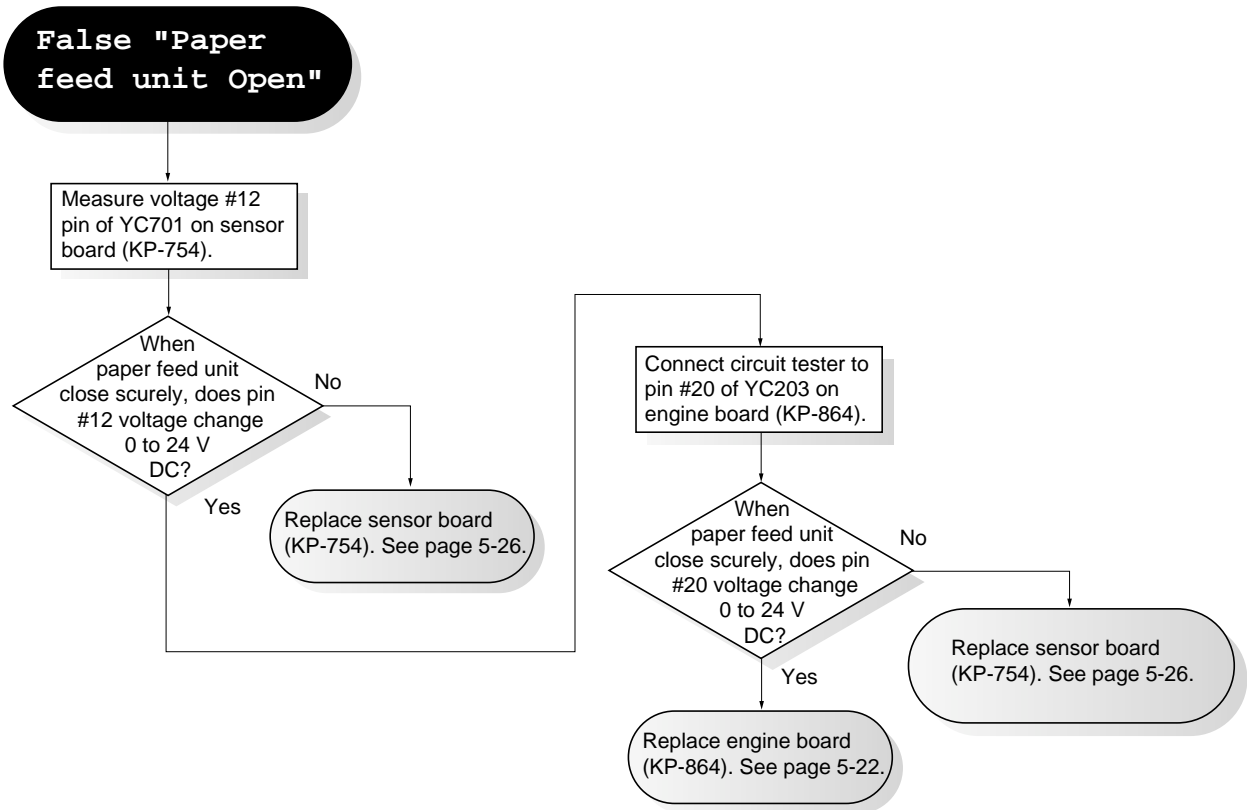

(2) False "Top cover Open"

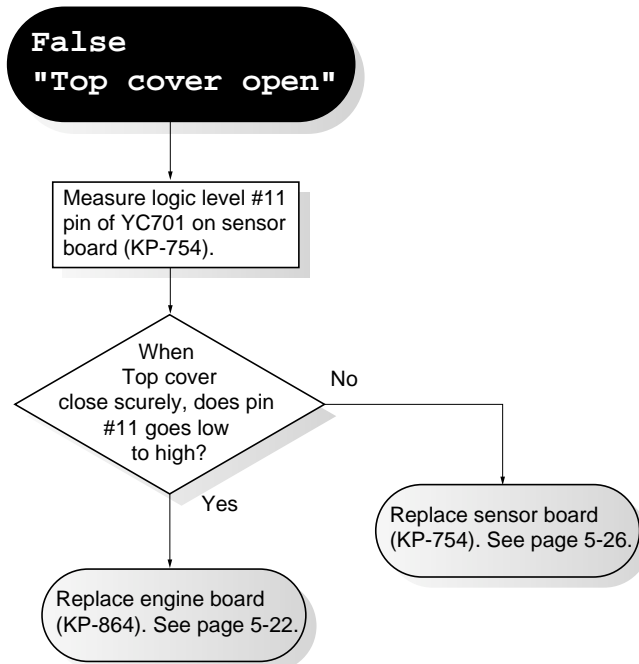

(3) False "Side cover Open"

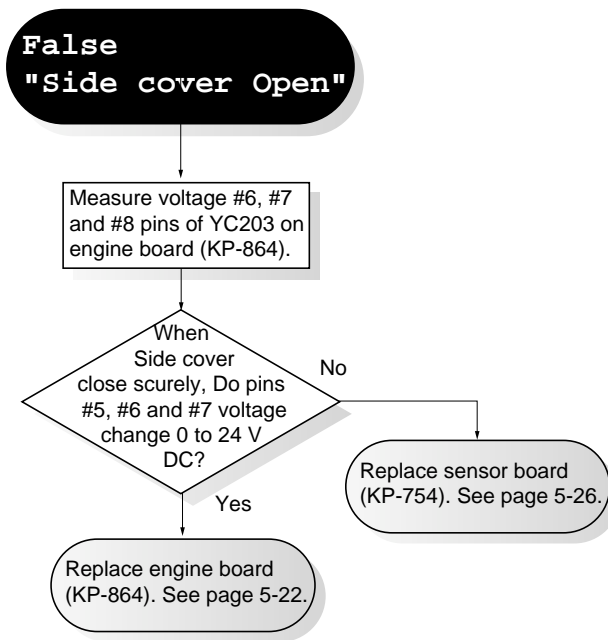

(4) Defective waste toner bottle detecting

Problem	Suggested causes	Corrective action
Although new waste toner bottle is installed, Check waste toner bottle is displayed.	<ul style="list-style-type: none"> Defective waste toner full sensor [board] (KP-766) or waste toner sensor (receiver). Deformed pins of connector (YC702) on the sensor board (KP-574). 	Replace drum unit. See page 5-12. Check and straighten pins of connector (YC702) on the sensor board (KP-574).
Although waste toner bottle is not installed, Ready is displayed.	<ul style="list-style-type: none"> Defective engine board (KP-864). 	Replace engine board (KP-864).

(5) Defective paper jam detecting

Problem	Suggested causes	Corrective action
Paper jam frequently occurs.	<ul style="list-style-type: none"> • Surface of the registration sensor (PH701) is dirty with paper particles. 	Clean with cloth.
False paper jam message display.	<ul style="list-style-type: none"> • Actuators of registration sensor (PH701) or exit sensor does not operate smoothly. 	Repair or replace.
	<ul style="list-style-type: none"> • Defective sensor board (KP-574), fuser board (KP-756) or engine board (KP-864). 	Replace sensor board (KP-574), fuser board (KP-756), or engine board (KP-864). See page 5-26 and 5-22.
	<ul style="list-style-type: none"> • A piece of paper torn from a sheet is caught around actuator of registration sensor or exit sensor. 	Check visually and remove it, if any.

(6) Defective paper gauge sensing

Problem	Suggested causes	Corrective action
False paper gauge indication.	<ul style="list-style-type: none"> • Surface of the paper gauge sensor 1 (PH702) and 2 (PH703) on the sensor board (KP-574) are dirty with paper particles. 	Clean with cloth.
	<ul style="list-style-type: none"> • A piece of paper torn from a sheet is caught around paper gauge sensor 1 (PH702) and 2 (PH703) on the paper sensor board (KP-574). 	Check visually and remove it, if any.
	<ul style="list-style-type: none"> • Reflecting mirror has come off the actuator of paper gauge sensor 1 (PH702) and 2 (PH703). 	Check visually and remove it, if any.
	<ul style="list-style-type: none"> • Defective paper gauge sensor 1 (PH702) and 2 (PH703) on the sensor board (KP-574). 	Replace sensor board (KP-574). See page 5-26.
	<ul style="list-style-type: none"> • Defective engine board (KP-864). 	Replace engine board (KP-864). See page 5-22.

(7) Defective paper size detecting

Problem	Suggested causes	Corrective action
False paper size message display.	<ul style="list-style-type: none"> • Defective paper size switch. 	Replace paper size switch.
	<ul style="list-style-type: none"> • Defective sensor board (KP-574). 	Replace sensor board (KP-574). See page 5-26.
	<ul style="list-style-type: none"> • Defective engine board (KP-864). 	Replace engine board (KP-864). See page 5-22.

(8) Defective message displaying (LCD)

Problem	Suggested causes	Corrective action
No message appears on the message display (LCD), though the message background is faintly illuminated.. (Power is supplied to the LCD controller board [KP-738] .)	• Defective main board (system DIMM board [KP-710* ¹ /KP-689* ²]).	Replace main board (system DIMM [board]).
	• Defective LCD controller board (KP-738).	Replace LCD controller board (KP-738).
	• Defective engine board (KP-864).	Replace engine board (KP-864).
	• Improper connection of harness (S02402) between LCD controller board (KP-738) and engine relay board (KP-760).	Reinsert the connector.
	• Improper connection of harness (S02405) between engine board (KP-864) and engine relay board (KP-760).	Reinsert the connector.
	• Defective main board (system DIMM [board KP-710* ¹ /KP-689* ²]).	Replace main board (system DIMM [board]).
No message appears on the message display (LCD), even though the message background does not illuminate faintly. (The power is not supplied to the LCD controller board [KP-738].)	• Defective LCD controller board (KP-738).	Replace LCD controller board (KP-738).
	• Defective engine board (KP-864).	Replace engine board (KP-864).
	• Improper connection of harness (S02402) between LCD controller board (KP-738) and engine relay board (KP-760).	Reinsert the connector.
	• Improper connection of harness (S02405) between engine board (KP-864) and engine relay board (KP-760).	Reinsert the connector.
	• Broken power cord.	Replace the power cord.
	• The power cord is not plugged in properly.	Check the contact between the printer's AC inlet and the outlet.
	• No electricity at the power outlet.	Measure the AC power voltage at the outlet.
	• Defective power supply unit.	Replace the power supply unit. See page 5-22.

*1 : FS-1800/1800N *2 : FS-3800/3800N

(9) Defective face up/down solenoid operating

Problem	Suggested causes	Corrective action
Change guide does not operate in the fuser unit.	<ul style="list-style-type: none"><li data-bbox="504 262 1091 387">• Improper insertion of the face up/down solenoid connector into fuser board (KP-756).<li data-bbox="504 396 1091 521">• Broken face up/down solenoid coil or blown-out fuse (ICP831) on the fuser board (KP-756).	Reinsert the connector. Remove and then check for continuity across the face up/down solenoid connector terminals; pin #1 and pin #2, pin #3 and pin #2. Remove and check for continuity of fuser board (KP-756) connectors terminals; across the pin #2 of connector (YC832) and pin #2 of connector (YC831). If none, replace the face up/down solenoid and fuser board (KP-756) at the same time. Or replace fuser unit. See page 5-29.

6-1-4 Circuit board terminal voltages

(1) Engine board

Connector	Pin#	Signal	I/O	Voltage	Function
YC201	A1	GND	-	-	Signal ground
	B1	GND	-	-	Signal ground
	A2	+5V1	I	5 V DC	Power supply for main board
	B2	+5V1	I	5 V DC	Power supply for main board
	A3	+5V1	I	5 V DC	Power supply for main board
	B3	SIOUT	O	3.3 V/0 V DC	Serial data output signal
	A4	SDIR	O	3.3 V/0 V DC	Serial line direction signal
	B4	SCLKN	O	3.3 V/0 V DC (Pulse)	Serial clock signal
	A5	EGIR	O	3.3 V/0 V DC	Engine interrupt request signal Interrupt/Not Interrupt
	B5	SBSY*	O	0 V/3.3 V DC	Serial line busy signal, Busy/Not busy
	A6	VDFON1	O	0 V/3.3 V DC	Forced video data output signal, On/Off
	B6	SOIN	I	3.3 V/0 V DC	Serial data input signal
	A7	VSREQ*	O	0 V/3.3 V DC	Vertical synchronized request signal Request/Not request
	B7	SYSRES*	O	0 V/3.3 V DC	System reset signal, Reset/Not reset
	A8	GND	-	-	Signal ground
	B8	PDOUT*	O	0 V/3.3 V DC (Pulse)	Pin photo diode sensor [board], Laser beam detecting signal
	A9	GND	-	-	Signal ground
	B9	GND	-	-	Signal ground
	A10	GND	-	-	Signal ground
	B10	VDO+	I	1.02 to 1.38 V DC	LVDS video data signal (positive)
	A11	GND	-	-	Signal ground
	B11	VDO-	I	1.38 to 1.02 V DC	LVDS video data signal (negative)
	A12	FPDIR	O	3.3 V/0 V DC	Communication direction signal with LCD controller board
	B12	GND	-	-	Signal ground
A13	+3.3V1	O	3.3 V DC	Power supply for LCD controller board	
B13	FPCLK	O	3.3 V/0 V DC (Pulse)	Communication data clock signal with LCD controller board	
A14	GND	-	-	Signal ground	
B14	FPDATA	I/O	3.3 V/0 V DC (Pulse)	Communication data signal with LCD controller board	

Connector	Pin#	Signal	I/O	Voltage	Function
YC201	A15	20PSEL5	O	5 V/0 V DC	Option unit identifying signal 5
	B15	GND	-	-	Signal ground
	A16	20PSEL3	O	5 V/0 V DC	Option unit identifying signal 3
	B16	20PSEL4	O	5 V/0 V DC	Option unit identifying signal 4
	A17	GND	-	-	Signal ground
	B17	20PTRIG*	O	0 V/5 V DC	Reserved
	A18	20PSDO	O	5 V/0 V DC (Pulse)	Serial communication output signal
	B18	20PRDY*	I	0 V/5 V DC	Option unit ready signal, Ready, Not ready
	A19	20PSCLK	O	0 V/5 V DC (Pulse)	Serial communication clock signal with option unit
	B19	20PSDI	I	5 V/0 V DC (Pulse)	Serial communication input signal
	A20	OP24V	O	24 V DC	Power supply for option unit
	B20	OP5V	O	5 V DC	Power supply for option unit
YC202	1	+24V2	I	24 V DC	Power supply
	2	FDPFUL*	I	0 V/5 V DC	Paper full sensor, Paper full/Not full
	3	FUDR	O	0 V/24 V DC	Face up/down solenoid, Change to face down, On/Off
	4	FDDR	O	0 V/24 V DC	Face up/down solenoid, Change to face up, On/Off
	5	THERM	I	Analog	Thermistor detecting heat roller temperature signal
	6	EXITPAP*	I	0 V/5 V DC	Exit sensor, Paper Detected/Not detected
	7	+5V1	I	5 V DC	Power supply
	8	GND	-	-	Signal ground
	9	+24V2	I	24 V DC	Power supply
	10	SLEEP*	O	0 V/5 V DC	Energy saving mode, On/Off
	11	ZCROSS	I	5 V/0 V DC (pulse)	Zero cross signal
	12	HEATON*	O	0 V/5 V DC	Heater lamp, On/Off

Connector	Pin#	Signal	I/O	Voltage	Function
YC202	13	+5V1	I	5 V DC	Power supply
	14	+5V1	I	5 V DC	Power supply
	15	+5V1	I	5 V DC	Power supply
	16	+5V1	I	5 V DC	Power supply
	17	GND	-	-	Signal ground
	18	GND	-	-	Signal ground
	19	GND	-	-	Power ground
	20	GND	-	-	Power ground
	21	+24V1	I	24 V DC	Power supply
	22	+24V1	I	24 V DC	Power supply
	23	+24V1	I	24 V DC	Power supply
	24	+24V1	I	24 V DC	Power supply
YC203	1	+24V1	O	24 V DC	Power supply to sensor board
	2	+24V1	O	24 V DC	Power supply to sensor board
	3	+24V1	O	24 V DC	Power supply to sensor board
	4	GND	-	-	Not used
	5	GND	-	-	Not used
	6	+24V2	I	24 V DC	Power supply
	7	+24V2	I	24 V DC	Power supply
	8	+24V2	I	24 V DC	Power supply
	9	ERASEDR	O	0 V/14.7 V DC	Eraser lamp [board], Turn On/Off
	10	WTNLED*	O	0 V/4.3 V DC	Waste toner full sensor [board] (light emitting), Turn On/Off
	11	TNRFUL*	O	0 V/4.1 V DC	Waste toner full sensor (light receiving), Toner full Detected/Not detected (Signal validates during WTNLED* signal output.)
	12	-		- -	Reserved
	13	+5V2	O	5 V/0V DC	Power supply to sensor board, Printer status Ready/Sleep
	14	GND	-	-	Signal ground
	15	EEDIO	I/O	5 V/0 V DC (pulse)	EEPROM (Drum board) data signal
	16	EECLK	O	5 V/0 V DC (pulse)	EEPROM (Drum board) clock signal
	17	REGPAP*	I	0 V/5 V DC	Registration sensor, Paper Detected/Not detected
	18	PVOLAN1	I	0 V/5 V DC	Paper gauge sensor 1, On/Off
	19	TCOVOP	I	0 V/5 V DC	Top cover switch, On/Off

Connector	Pin#	Signal	I/O	Voltage	Function
YC203	20	FCOVOP*	I	24 V/0 V DC	Top cover/paper feed unit interlock switch, On/Off
	21	CSIZE	I	Analog	Paper size switch detecting signal
	22	PVOLAN2	I	0 V/5 V DC	Paper gauge sensor 2, On/Off
YC204	1	TRVSEL2*	O	0 V/24 V DC	Transfer bias output voltage control signal 2
	2	TRVSEL1*	O	0 V/24 V DC	Transfer bias output voltage control signal 1
	3	+5V1	O	5 V DC	Power supply for high voltage board
	4	TRVSEL3*	O	0 V/24 V DC	Transfer bias output voltage control signal 3
	5	TNEMP*	I	0 V/5 V DC	Toner sensor, Toner empty/Not empty
	6	TRCON*	O	0 V/24 V DC	Transfer bias, Output On/Off
	7	TONSCAN	O	5 V/0 V DC (Pulse)	Toner sensor, Toner detecting clock signal
	8	HVCLK	O	5 V/0 V DC (Pulse)	Developing bias output clock signal
	9	GND	-	-	Power ground
	10	MCHON*	O	0 V/24 V DC	Main charger, Output On/Off
	11	HUNIT*	I	5 V/0 V DC	Option feeder, Installed/Not installed
	12	RTRCHON*	O	0 V/24 V DC	Transfer bias output, Reverse On/Off
	13	HANDS*	I	0 V/5 V DC	MP tray paper sensor, Paper Detected/Not detected
	14	DLPTYPE	I	Analog	Developer identifying signal
	15	+5V2	O	5 V DC	Power supply for high voltage board
	16	TMOTDR	O	24 V/0 V DC	Toner motor, Drive/Stop
	17	CONTYPE	I	5 V DC (0 V/5 V DC)	Toner container identifying signal (MICR model only)
	18	+24V2	O	24 V DC	Power supply for high voltage board
YC205	1	OP24V	O	24 V DC	Power supply for option unit
	2	GND	-	-	Signal ground
	3	OP5V	O	5 V DC	Power supply for option unit
	4	-	-	-	Reserved
	5	OPSCLK	-	5 V/0 V DC (Pulse)	Serial communication clock signal

Connector	Pin#	Signal	I/O	Voltage	Function
YC205	6	OPSEL0	O	0 V/5 V DC	Option unit identify signal 0
	7	OPSDI	I	5 V/0 V DC	Serial communication data signal with option unit
	8	OPSEL1	O	0 V/5 V DC	Option unit identifying signal 1
	9	OPSDO	O	5 V/0 V DC	Serial communication data signal with option unit
	10	OPSEL2	O	0 V/5 V DC	Option unit identifying signal 2
	11	OPRDY*	I	0 V/5 V DC	Option unit, Ready/Not ready
	12	GND	-	-	Signal ground
YC206	1	+24V2	O	24 V DC	Power supply for engine relay board
	2	+3.3V1	O	3.3 V DC	Power supply for LCD controller board
	3	MPFSOL*	O	0 V/24 V DC	MP tray feed solenoid, On/Off
	4	FPDATA	I/O	3.3 V/0 V DC	LCD controller board data signal
	5	MIDDR*	O	0 V/24 V DC	Middle feed clutch, On/Off
	6	FPDIR	I	3.3 V/0 V DC	LCD controller board
	7	+24V2	O	24 V DC	Power supply for engine relay board
	8	FPCLK	I	3.3 V/0 V DC (Pulse)	Communication data clock signal
	9	GND	-	-	Power/Signal ground
	10	GND	-	-	Power/Signal ground
	11	FEDDR*	O	0 V/24 V DC	Feed clutch, On/Off
	12	FPRST*	O	3.3 V/0 V DC	LCD controller board reset signal
	13	+24V2	O	24 V DC	Power supply for engine relay board
	14	FANDR	O	24 V/15 to 16 V/0 VDC	Cooling fan motor, Speed control High/Low/Stop
	15	REGDR*	O	0 V/24 V DC	Registration clutch, On/Off
	16	MMOTON*	O	0 V/5 V DC	Main motor, Drive/Stop
	17	GND	-	-	Power/Signal ground
	18	MMOTRDY*	O	0 V/5 V DC	Main motor, Ready/Not ready
	19	+5V3	O	5 V DC	Power supply for laser scanner unit
	20	SAMPLE1*	O	0 V/5 V DC (Pulse)	Laser power data sample and hold control signal Data Sampling/Not sampling
	21	POWCONT	O	0 V/5 V DC	Laser power level control signal, High/Low
	22	LASER*	O	0 V/5 V DC	Laser power output signal, Enable/Disable

Connector	Pin#	Signal	I/O	Voltage	Function
YC206	23	VDO+	O	1.02 to 1.38 V DC	LVDS video data signal (positive)
	24	VDO-	O	1.38 to 1.02 V DC	LVDS video data signal (negative)
	25	GND	-	-	Power/Signal ground
	26	+5V3	O	5 V DC	Power supply for laser scanner unit step-downed from 24 V DC (+24V2)
	27	PDIN*	I	0 V/5 V DC	Pin photo diode sensor detecting signal
	28	GND	-	-	Power/Signal ground
	29	POLCLK	O	0 V/5 V DC (Pulse)	Polygon motor rotation speed control clock signal
	30	POLRDY*	I	0 V/5 V DC	Polygon motor start-up ready signal, Ready/Not ready
	31	POLON*	O	0 V/5 V DC	Polygon motor drive signal, Drive/Stop
	32	GND	-	-	Power/Signal ground
	33	+24V2	O	24 V DC	Power supply for laser scanner unit
	34	GND	-	-	Power/Signal ground
	YC209	1	AIRTEMP	I	Analog
2		+5V1	O	5 V DC	Power supply for engine relay board
3		WETCK1	O	0 V/5 V DC (Pulse)	Temperature/humidity sensor drive clock signal 1
4		WETCK2	O	0 V/5 V DC (Pulse)	Temperature/humidity sensor drive clock signal 2

6-1-5 Assignment of circuit board connector pins

When measuring voltage or signal of circuit board installed in the printer, refer to the pin assignment figure below. For further information of each pins and other circuit board, refer to section Appendix A *Wiring diagram* on page A-20.

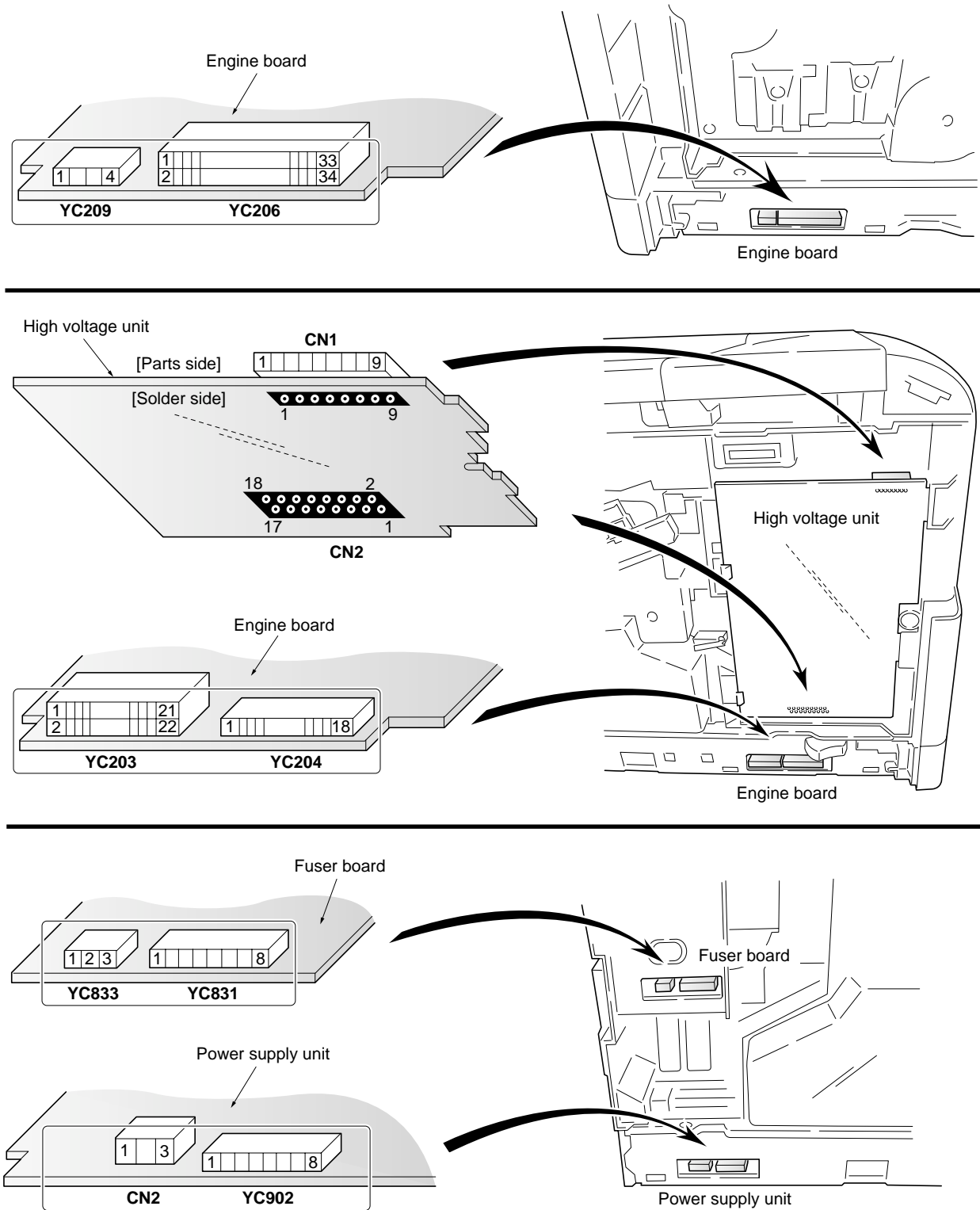

Figure 6-1-1 Assignment of circuit board connector pins

6-1-6 Print quality problems

Print quality problems range from uneven tone to completely blank output. The troubleshooting procedure for each type of problem is given below.

(1) Completely blank printout

See page 6-38.

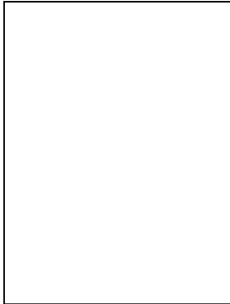

(2) All-black printout

See page 6-39.

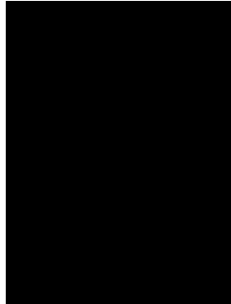

(3) Dropouts

See page 6-40.

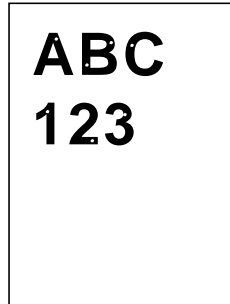

(4) Black dots

See page 6-41.

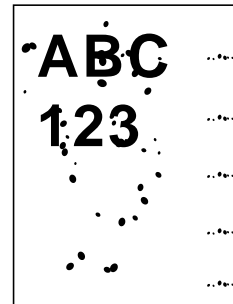

(5) Black horizontal streaks

See page 6-41.

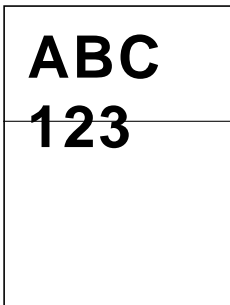

(6) Black vertical streaks

See page 6-42.

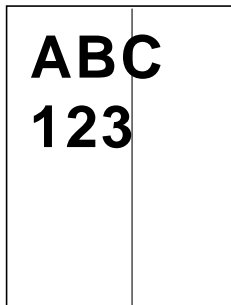

(7) Unsharpness

See page 6-43.

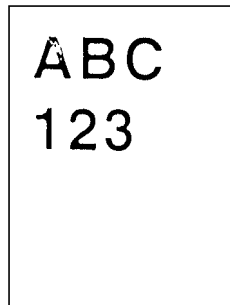

(8) Gray background

See page 6-44.

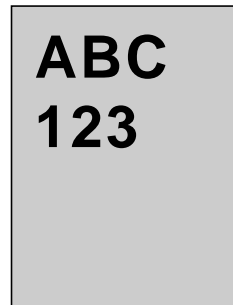

(9) Dirt on the top edge or back of the paper

See page 6-45.

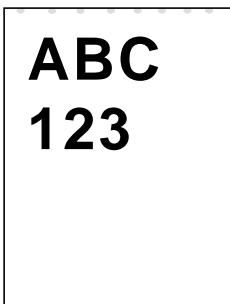

(10) Undulated printing at the left edge (scanning start position)

See page 6-46.

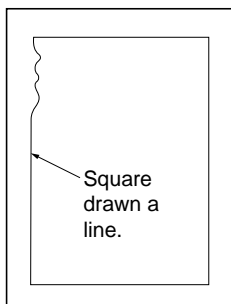

(1) Completely blank printout

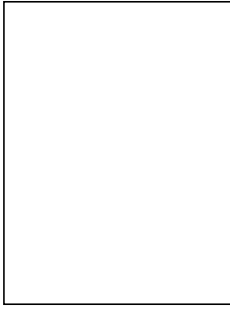

Check the developer.

- Check that the developer is inserted correctly. See page 5-4.
- Check that the toner on the magnet roller surface. See page 5-4.

Check the transfer bias potential.

- Check the transfer bias output on the high voltage unit. This requires removal of the left cover and the test equipment. Replace the high voltage unit if high voltage potential is not available on the board. See page 5-25.

Check the laser scanner unit.

- The scanner components within the scanner may be disordered. Replace the laser scanner unit. See page 5-37.

(2) All-black printout

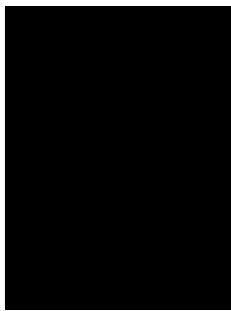

Check the main charger unit

- Open the printer side cover and check that the drum unit is correctly seated. Check for poor contact of the main charger terminal between the main charger unit and the drum unit.

Check the drum bias.

- Make sure the bias from the high voltage unit correctly arrives at the drum unit.

Check high voltage potential at the high voltage unit.

- Check the high voltage output on the high voltage unit. Replace the high voltage unit if high voltage potential is not available on the board.

(3) Dropouts

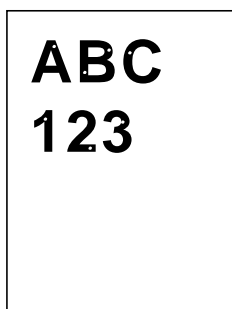

Note the spacing of the defects. Refer to *Repetitive defects gauge*. See page 6-47.

- If the defects occur at regular intervals of 39 mm, the problem may be the damaged developing roller (in the developer). Replace the developer. See page 3-13.
- If the defects occur at regular intervals of 94 mm, the problem may be the damaged drum (in the drum unit). Replace the drum unit. See page 5-12.
- If the defects occur at regular intervals of $72^{*1}/94^{*2}$ mm (heat roller) or 79 mm (press roller), the problem may be the damaged fuser unit. Replace the press roller or heat roller. See page 5-34 or 5-36. *1: FS-1800/1800N *2: FS-3800/3800N

Check paper property.

- Paper with rugged surface or dump tends to cause dropouts. Replace paper with the one that satisfies the paper specifications.

Check the transfer roller installation.

- The transfer roller must be supported by the bushes at the both ends. Clean the bush to remove oil and debris. Replace the transfer roller if necessary. See page 5-17.

Check the transfer bias potential.

- Check the transfer bias output on the high voltage unit. This requires removal of the left cover and the test equipment. Replace the high voltage unit if high voltage potential is not available on the board. See page 5-25.

(4) Black dots

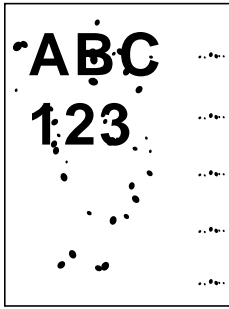

Note the spacing of the defects. Use the *Repetitive defects gauge*. See page 6-47.

- If the defects occur at regular intervals of 94 mm, the problem may be the damaged drum (in the drum unit). Replace the drum unit. See page 5-12.
- If the defects occur at random intervals, the toner may be leaking from the developer and drum unit. Replace the developer and drum unit. See page 5-4 and 5-12.

(5) Black horizontal streaks

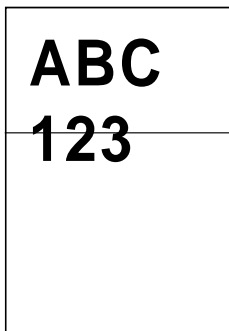

Check the drum unit's ground.

- The drum axle in the drum unit and its counter part, the grounding tab in the printer, must be in a good contact. If necessary, apply a small amount of electro-conductive grease onto the tab.

The drum may be defective.

- Replace the drum unit. See page 5-12.

(6) Black vertical streaks

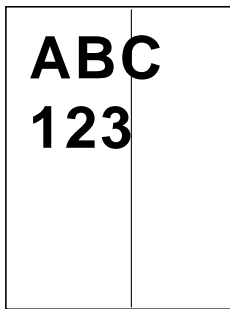

Contaminated main charger wire.

- Clean the main charger wire by pulling the green colored cleaning knob in and out several times. See page 3-9.

Check the drum surface for a streak of toner laying lengthwise.

- A streak of toner remaining on drum after printing means that the cleaning blade (in the drum unit) is not working properly. Replace the drum unit. See page 5-12.

Defective magnet roller (in the developer).

- Replace the developer. See page 5-4.

(7) Unsharpness

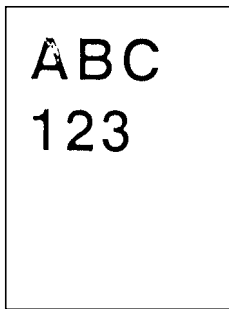

Check paper for property.

- Paper with rugged surface or dump tends to cause unsharp printing. Replace paper with the one that satisfies the paper specifications.

Check the transfer roller installation.

- The transfer roller must be supported by the bushes at the both ends. Clean the bush to remove oil and debris. Replace the transfer roller if necessary. See page 5-17.

Check the transfer bias potential.

- Check the transfer bias output on the high voltage unit. This requires removal of the left cover and the test equipment. Replace the high voltage unit if high voltage potential is not available on the board. See page 5-25.

Check *EcoPrint* setting.

- The *EcoPrint* mode can provides faint, unsharp printing because it acts to conserve toner for draft printing purpose. For normal printing, turn the *EcoPrint* mode off by using the operator panel. For details refer to the printer's *User's Manual*.

(8) Gray background

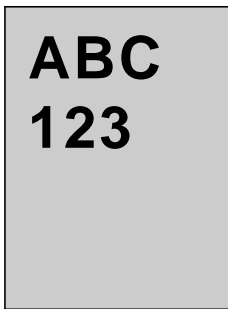

Check the print density setting.

- The print density may be set too high. Try adjusting the print density using the *Remote operation panel* utility. For details refer to the printer's *User's Manual*.

Check the surface potential of the drum (in the drum unit).

- The drum potential should be approximately 230 ± 15 V. This may vary depending on production lots. Measurement is possible only by using the jig and tool specifically designed for this purpose. The drum unit will have to be replaced if it bears values far out of the allowable range.

Check the grid.

- Clean the grid by grid cleaner. See page 3-9.

The developing roller (in the developer) may be defective.

- If a developer which is known to work normally is available for check, replace the current developer in the printer with the normal one. If the symptom disappears, replace the developer with a new one. See page 5-4.

(9) Dirt on the top edge or back of the paper

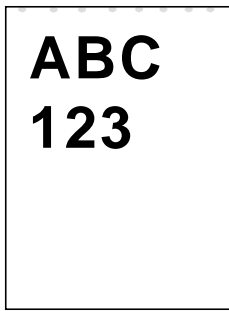

Check toner contamination in various parts.

- Dirty edges and back of the paper can be caused by toner accumulated on such parts as the paper chute, paper transportation paths, the bottom of the drum and developer, and the fuser unit inlet. Clean these areas and parts to remove toner.

Check the transfer roller.

- If the transfer roller is contaminated with toner, clean the transfer roller using a vacuum cleaner; or by continuously printing a low-density page until the symptom has faded away.

(10) Undulated printing at the left edge (scanning start position)

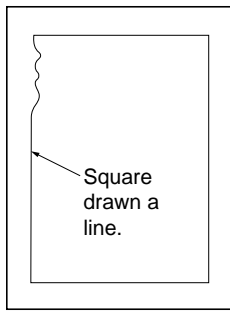

Replace the laser scanner unit.

- Defective polygon motor in the laser scanner unit. Replace the laser scanner unit. See page 5-37.

Replace the engine board.

- Defective engine controller circuit in the engine board (KP-864). Replace the engine board (KP-864). See page 5-22.

Repetitive defects gauge

Use the following measurements for checking repetitive occurrences on the printed page. This will help locating the roller, etc., which has the cause for these defects. See the above section for details.

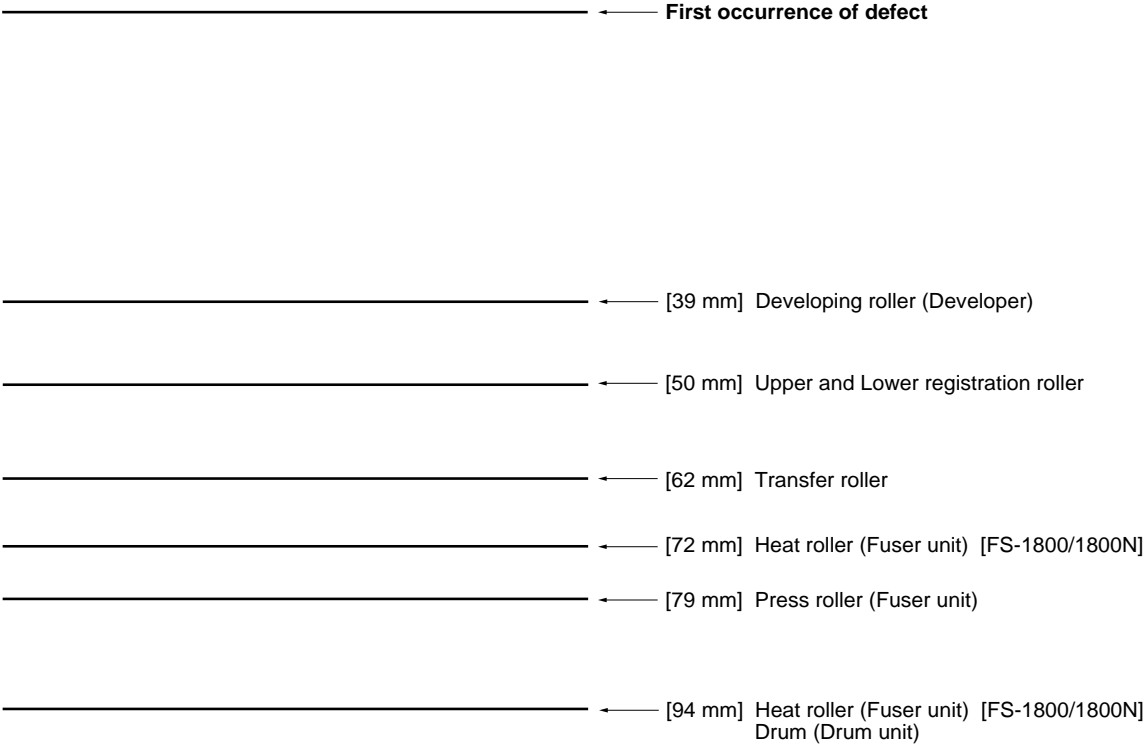

Figure 6-1-2 Repetitive defects gauge

6-1-7 Correcting a paper jam

If a paper jam occurs while you are printing, remove the jammed paper as described below. After you have removed the jammed paper, open and close the top cover or the paper feed unit.

While the paper jam message is displayed, press the **?** key. A on-line help message appears.

(1) Jam in the rear cover

1. While pulling the paper feed unit release lever **①**, pull out the paper feed unit **②**.

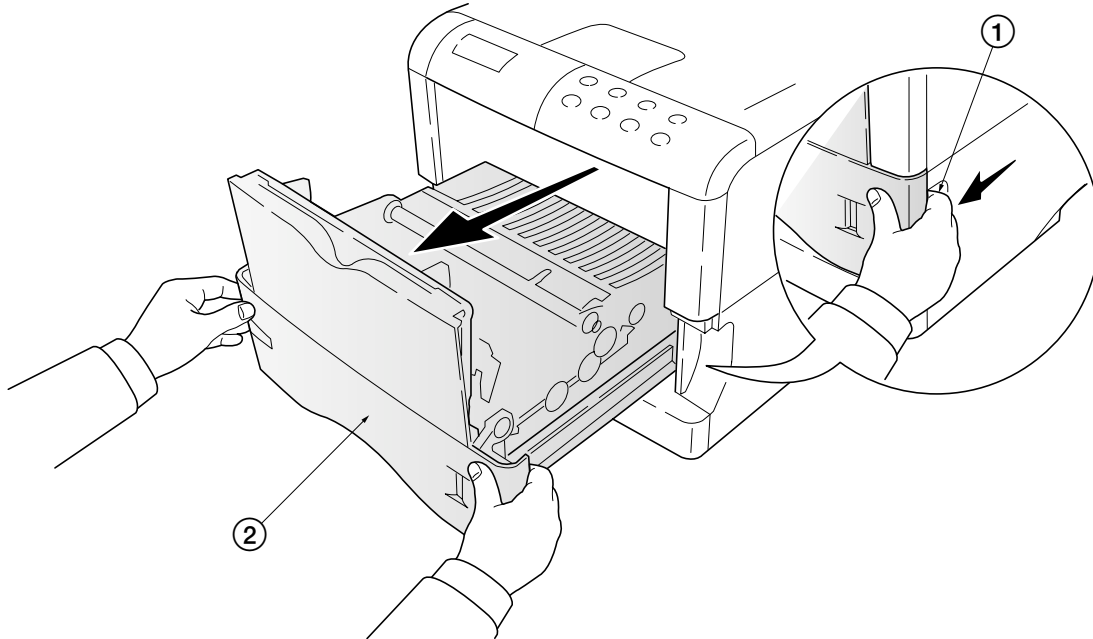

Figure 6-1-3 Drawing the paper feed unit

2. Open the rear cover **③** and remove the jammed paper as shown in the figure.

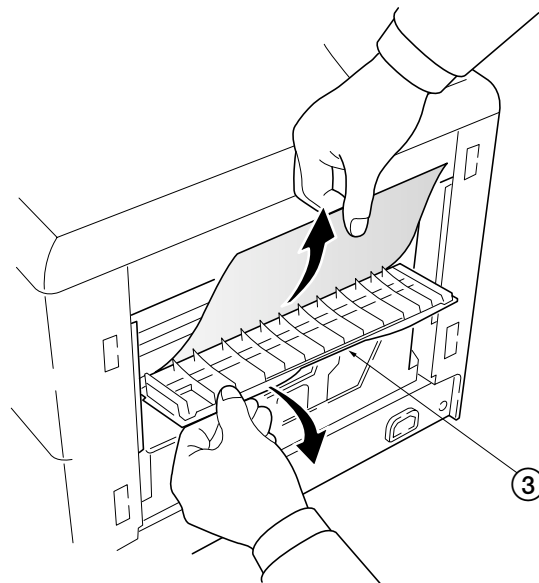

Figure 6-1-4 Jam in the rear cover

(2) Jam inside the printer

1. While pulling the paper feed unit release lever, pull out the paper feed unit (See previous page).
2. If paper is jammed before the registration roller, remove it as shown figure 6-1-5. If paper jammed under the registration roller, remove it as shown in figure 6-1-6.

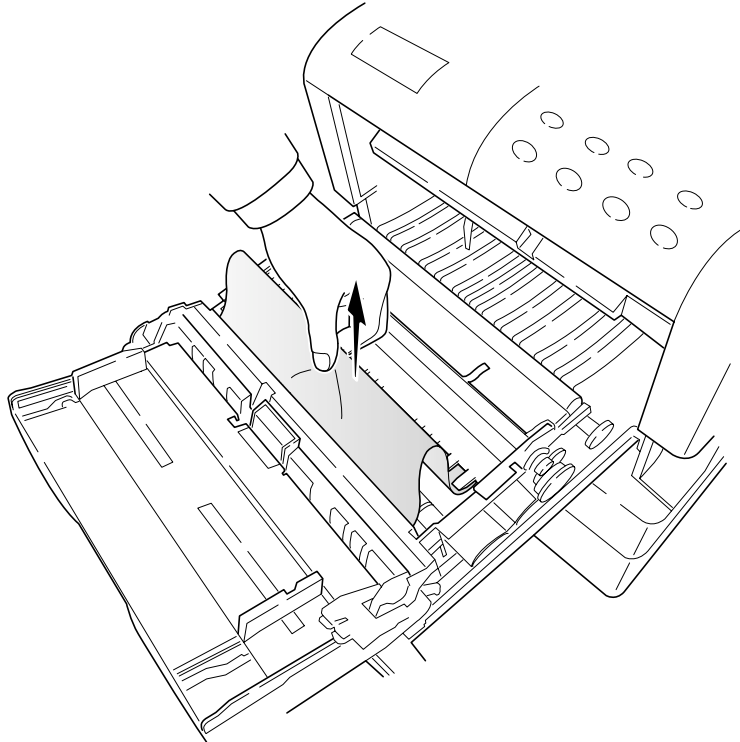

Figure 6-1-5 Jam in the printer (1)

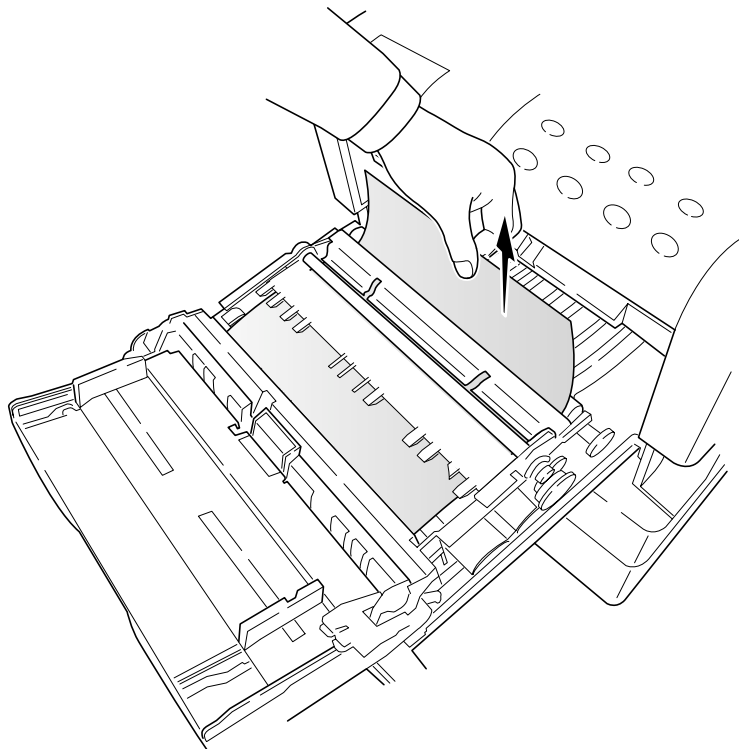

Figure 6-1-6 Jam in the printer (2)

Appendix A D i a g r a m s

Appendix A Contents

Timing charts	A-4
Cassette feeding, A4 size, face-down tray output.....	A-4
Cassette feeding, Letter size, face-down tray output.....	A-5
Cassette feeding, Legal size, face-down tray output.....	A-6
MP tray feeding, Letter size, face-down tray output.....	A-7
MP tray feeding, Legal size, face-down tray output.....	A-8
Wiring diagram	A-9
Schematic diagrams	A-10
Engine board 1/8.....	A-10
Engine board 2/8.....	A-11
Engine board 3/8.....	A-12
Engine board 4/8.....	A-13
Engine board 5/8.....	A-14
Engine board 6/8.....	A-15
Engine board 7/8.....	A-16
Engine board 8/8.....	A-17
Main board (TK-777) 1/12.....	A-18
Main board (TK-777) 2/12.....	A-19
Main board (TK-777) 3/12.....	A-20
Main board (TK-777) 4/12.....	A-21
Main board (TK-777) 5/12.....	A-22
Main board (TK-777) 6/12.....	A-23
Main board (TK-777) 7/12.....	A-24
Main board (TK-777) 8/12.....	A-25
Main board (TK-777) 9/12.....	A-26
Main board (TK-777) 10/12.....	A-27
Main board (TK-777) 11/12.....	A-28
Main board (TK-777) 12/12.....	A-29
Main board (TK-858) 1/12.....	A-30
Main board (TK-858) 2/12.....	A-31
Main board (TK-858) 3/12.....	A-32
Main board (TK-858) 4/12.....	A-33
Main board (TK-858) 5/12.....	A-34
Main board (TK-858) 6/12.....	A-35
Main board (TK-858) 7/12.....	A-36
Main board (TK-858) 8/12.....	A-37
Main board (TK-858) 9/12.....	A-38
Main board (TK-858) 10/12.....	A-39
Main board (TK-858) 11/12.....	A-40
Main board (TK-858) 12/12.....	A-41

Power supply unit (120 V AC model, Sanken®)	A-42
Power supply unit (220 - 240 V AC model, Sanken®)	A-43
Power supply unit (220 - 240 V AC model, Sharp®)	A-44

Timing charts

Cassette feeding, A4 size, face-down tray output

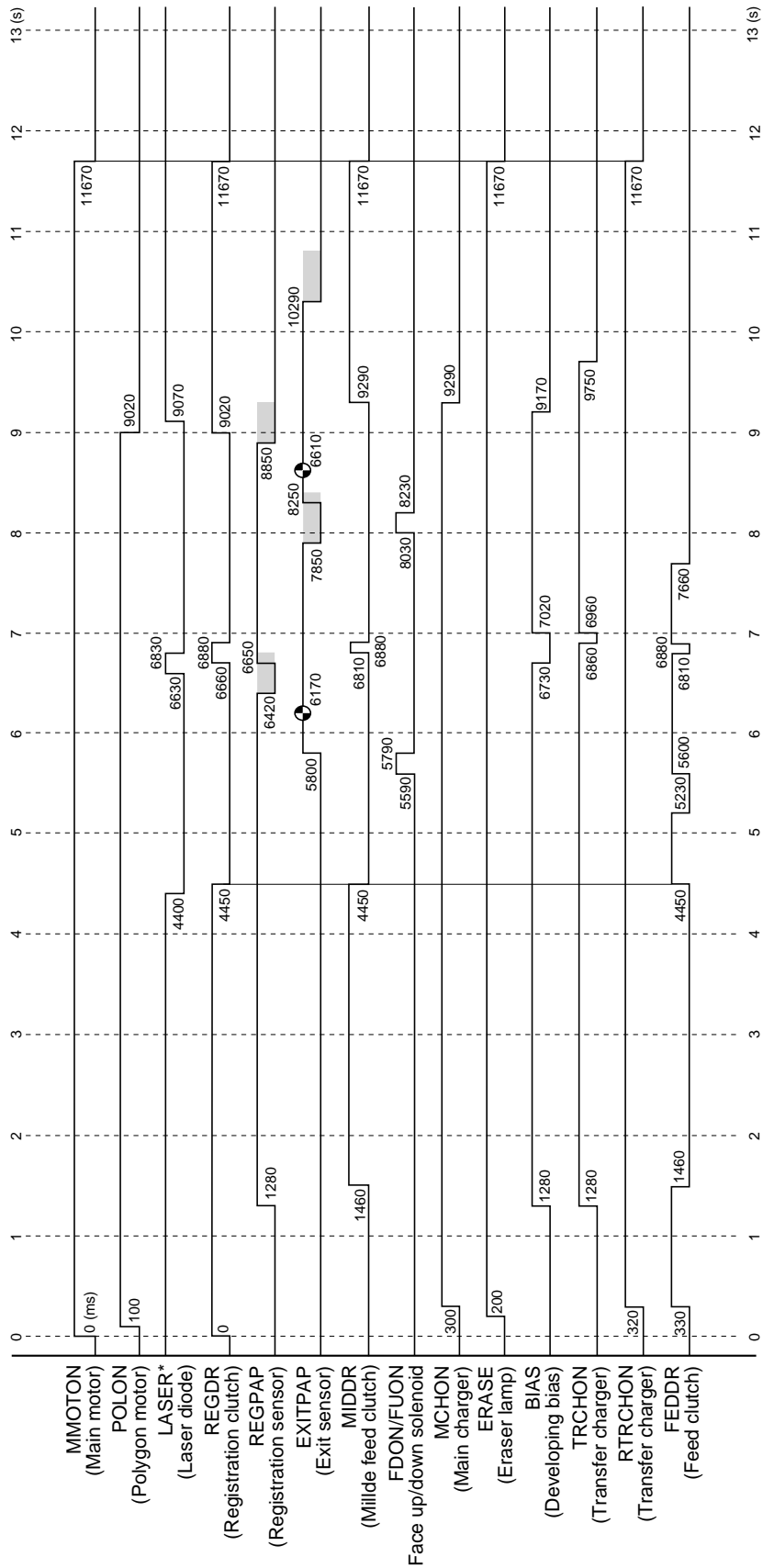

Drum speed: 147 mm/s
 Paper feeding speed: 147 mm/s
 ● : Detecting no presence of paper at this time indicates paper jam.
 ■ : Detecting presence of paper in this period of time indicates paper jam.

Cassette feeding, Legal size, face-down tray output

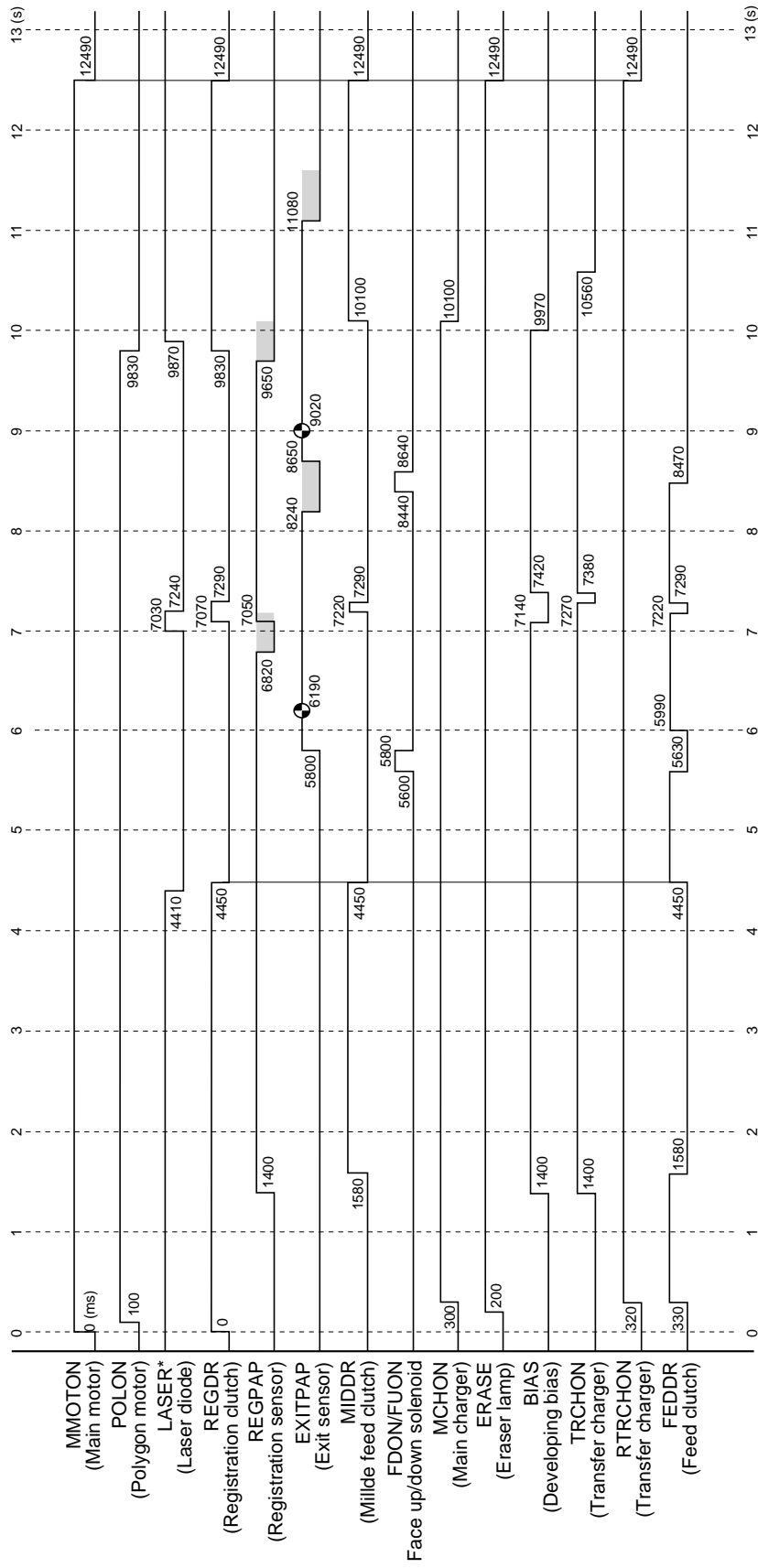

Drum speed: 147 mm/s
 Paper feeding speed: 147 mm/s

● : Detecting no presence of paper at this time indicates paper jam.

■ : Detecting presence of paper in this period of time indicates paper jam.

MP tray feeding, Letter size, face-down tray output

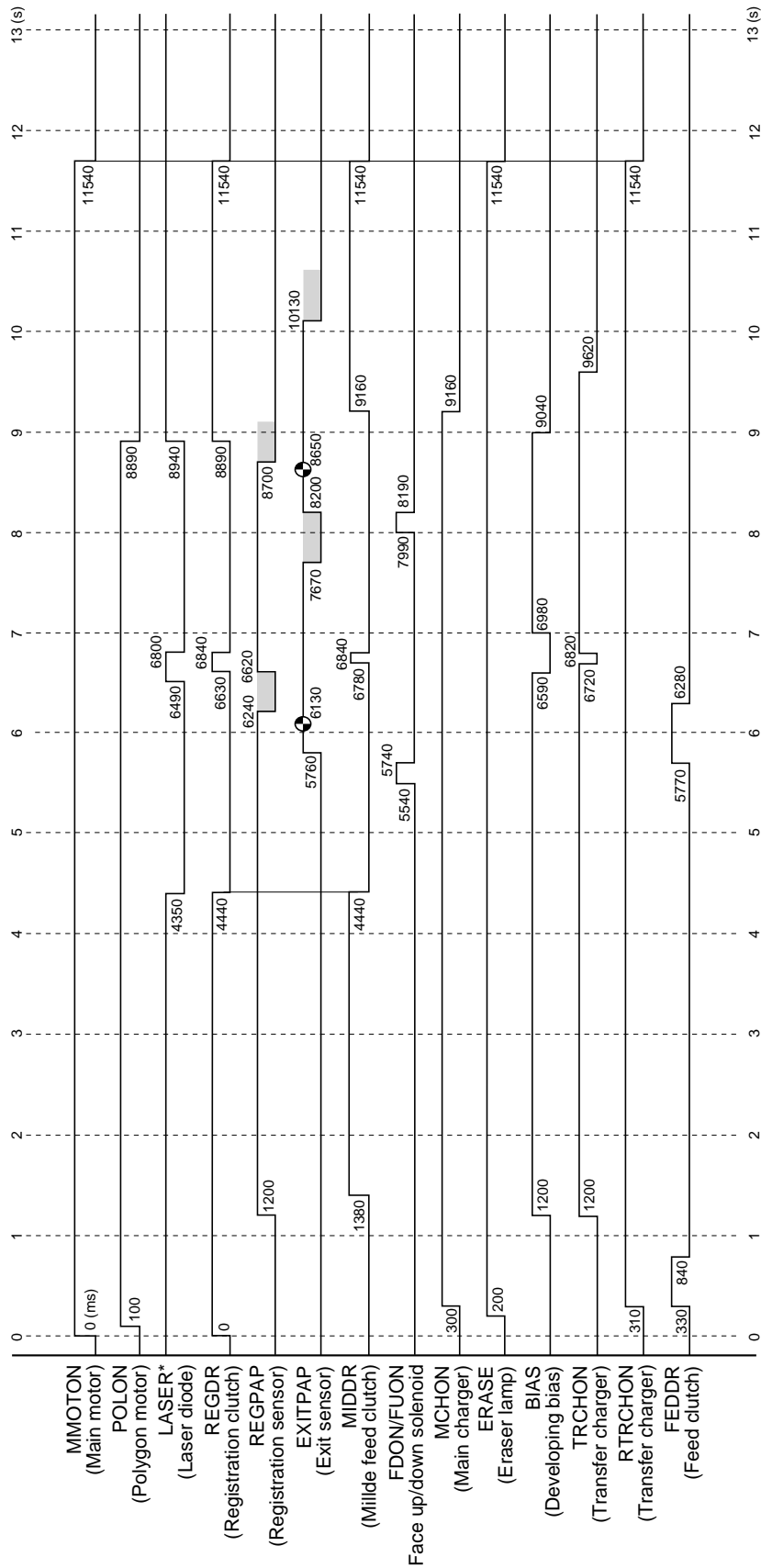

Drum speed: 147 mm/s
 Paper feeding speed: 147 mm/s
 ● : Detecting no presence of paper at this time indicates paper jam.
 ■ : Detecting presence of paper in this period of time indicates paper jam.

MP tray feeding, Legal size, face-down tray output

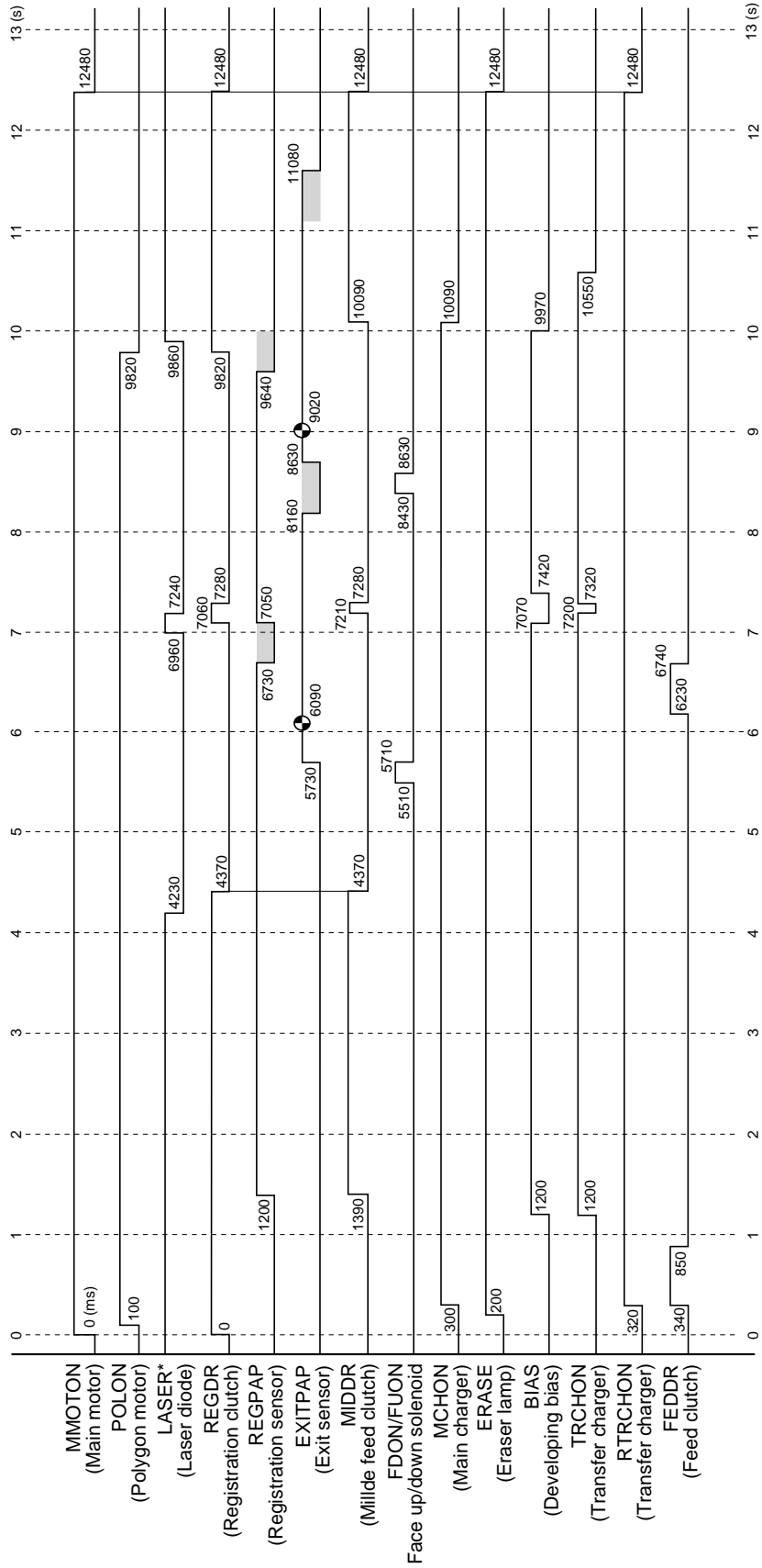

Drum speed: 147 mm/s
 Paper feeding speed: 147 mm/s
 ● : Detecting no presence of paper at this time indicates paper jam.
 ■ : Detecting presence of paper in this period of time indicates paper jam.

Wiring diagram

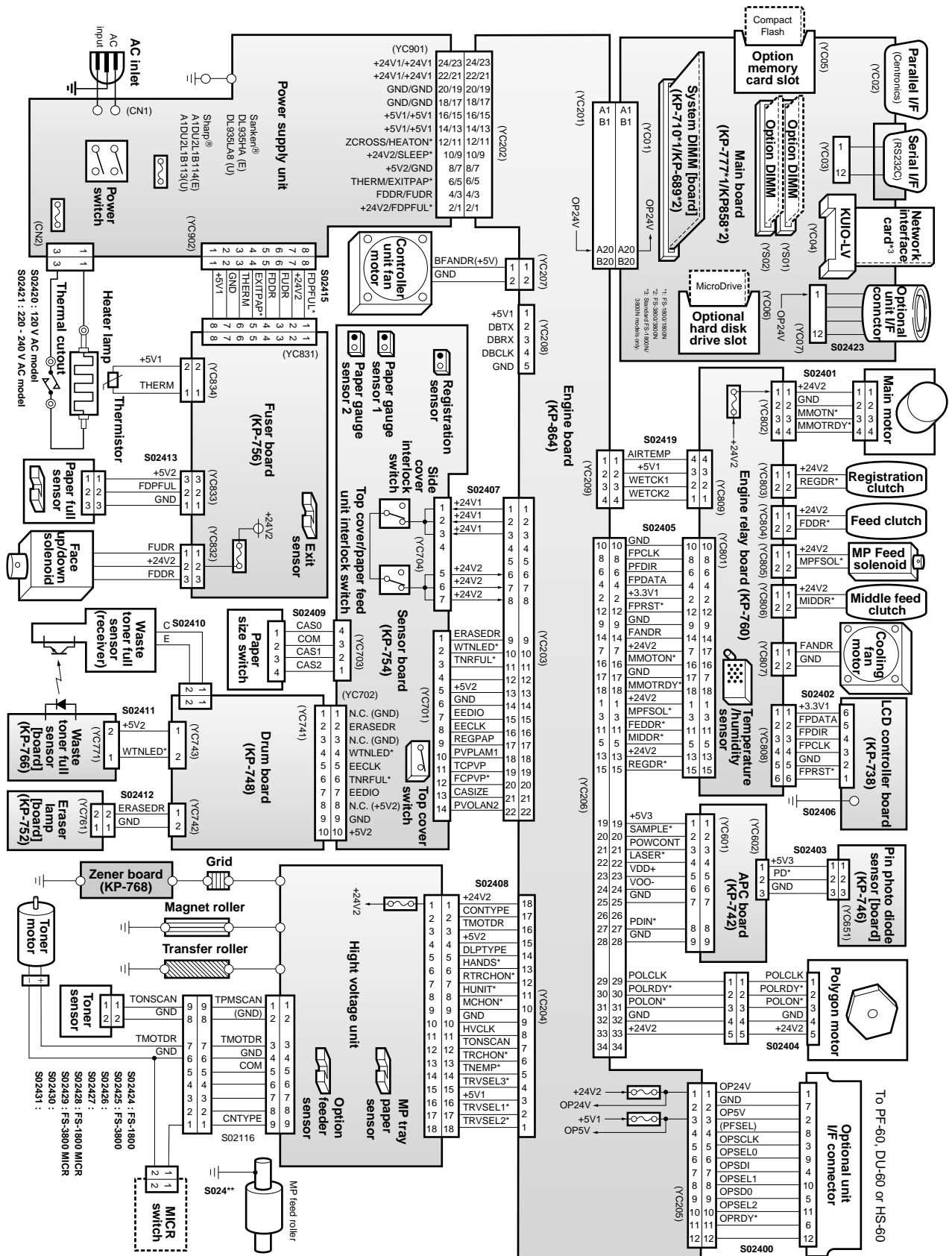

Engine board 2/8

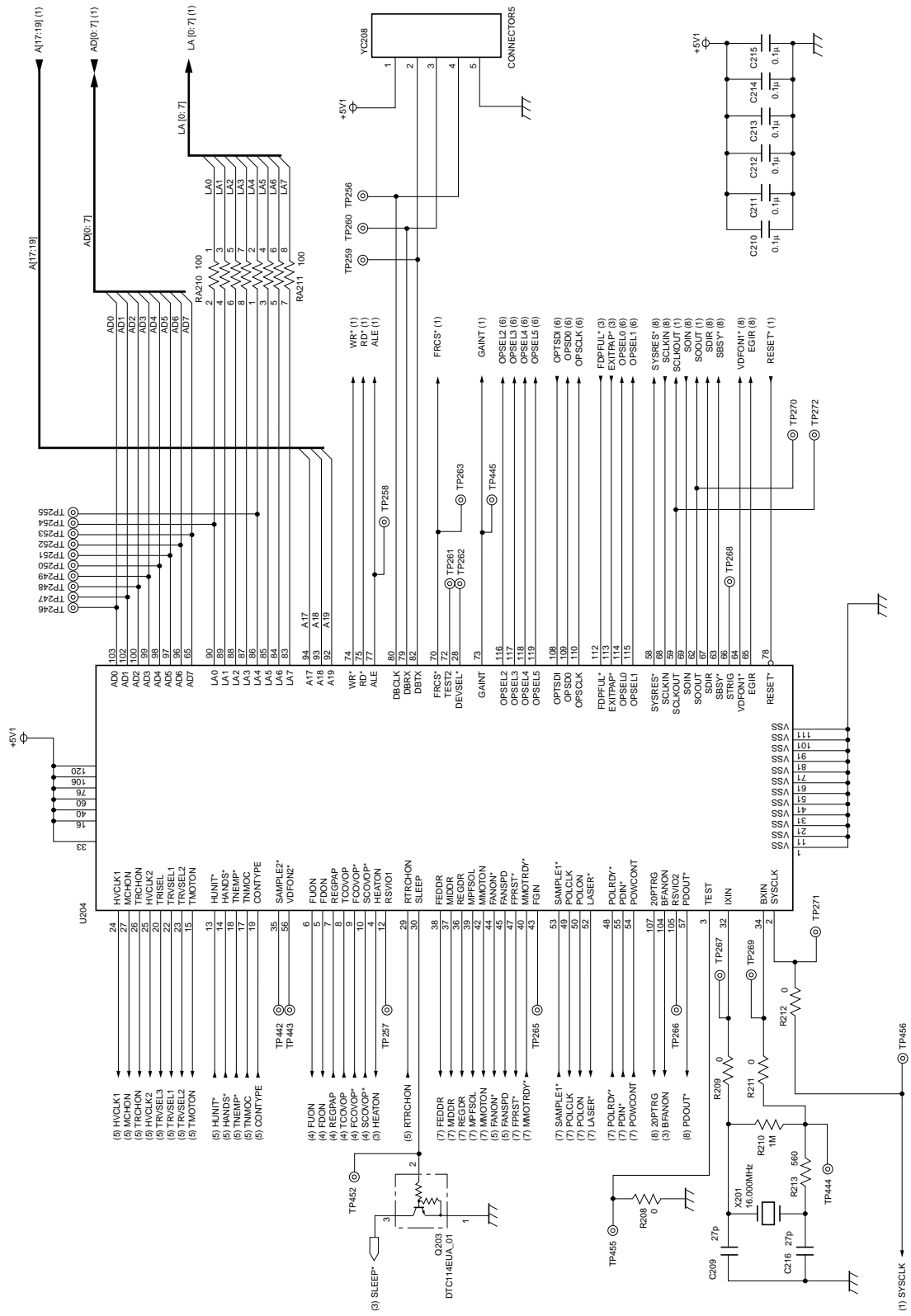

Engine board 3/8

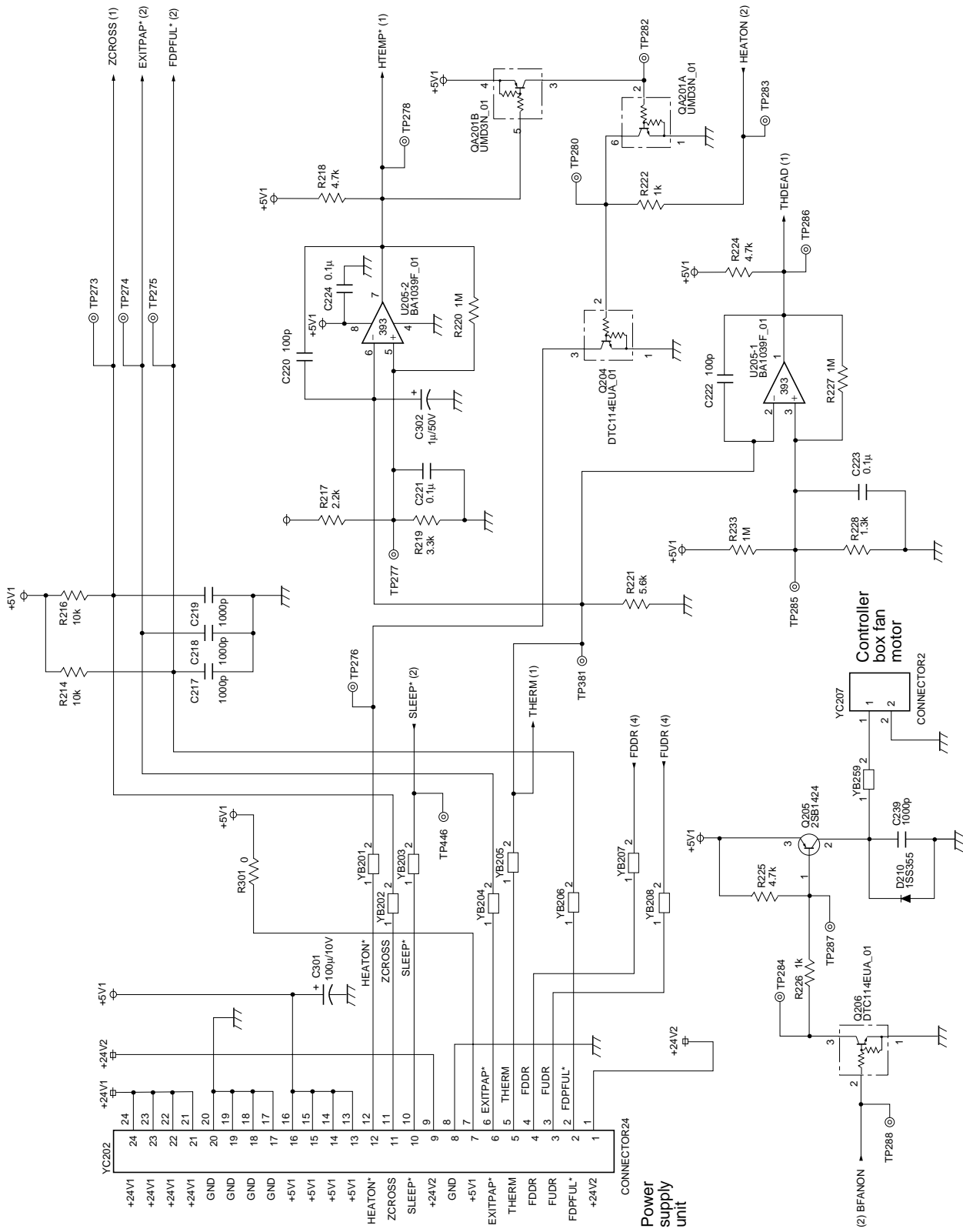

Engine board 4/8

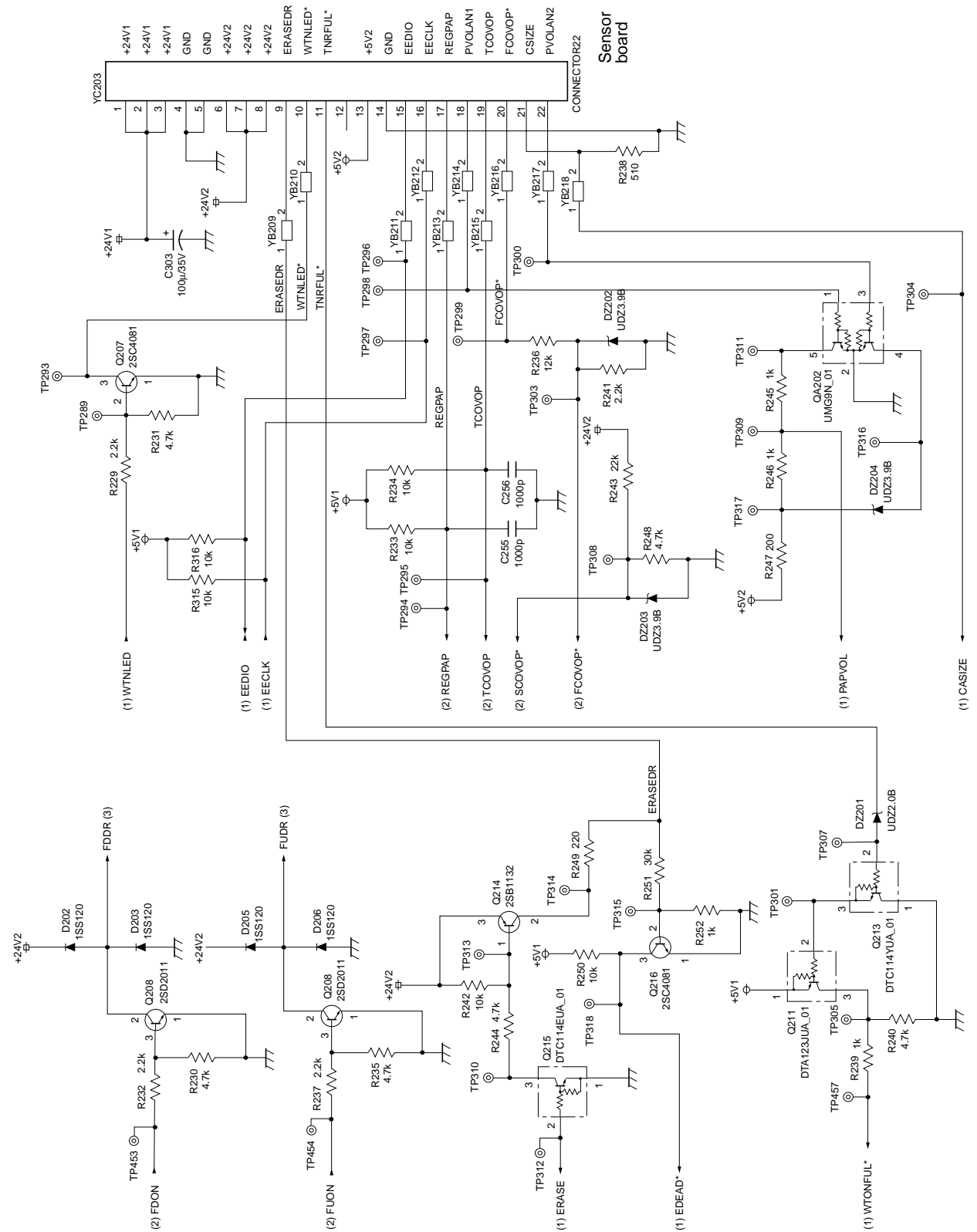

Engine board 5/8

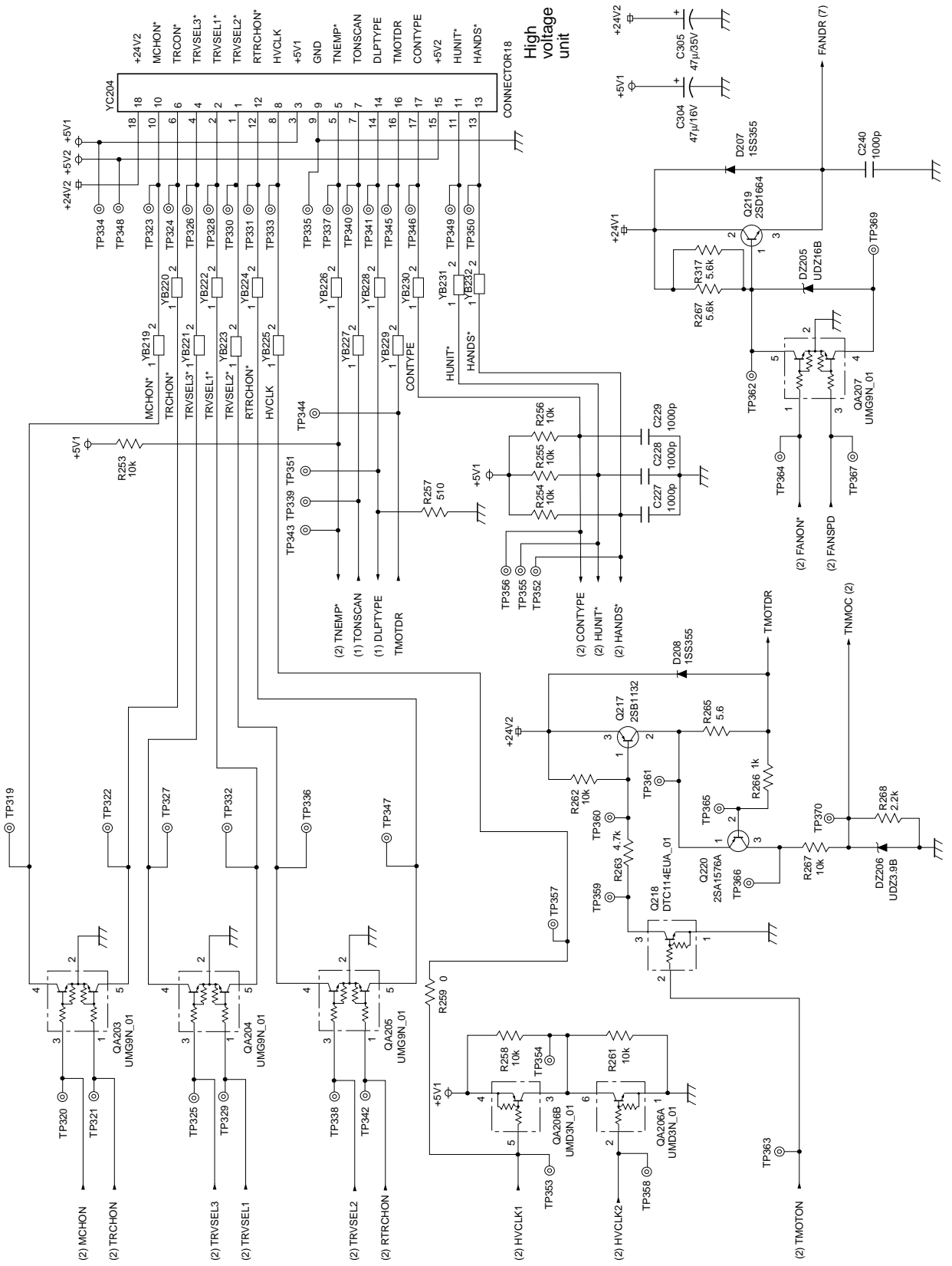

Engine board 6/8

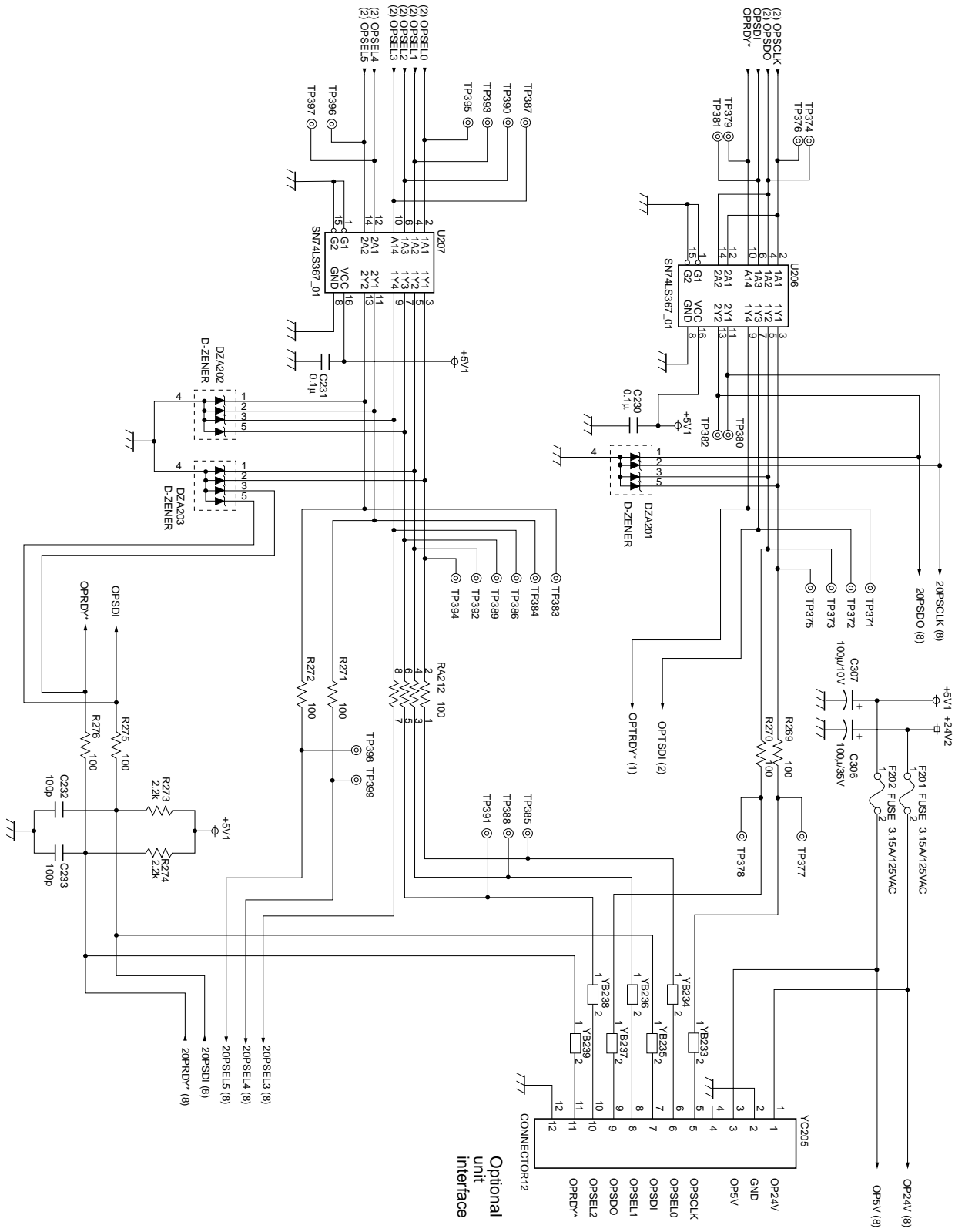

Engine board 7/8

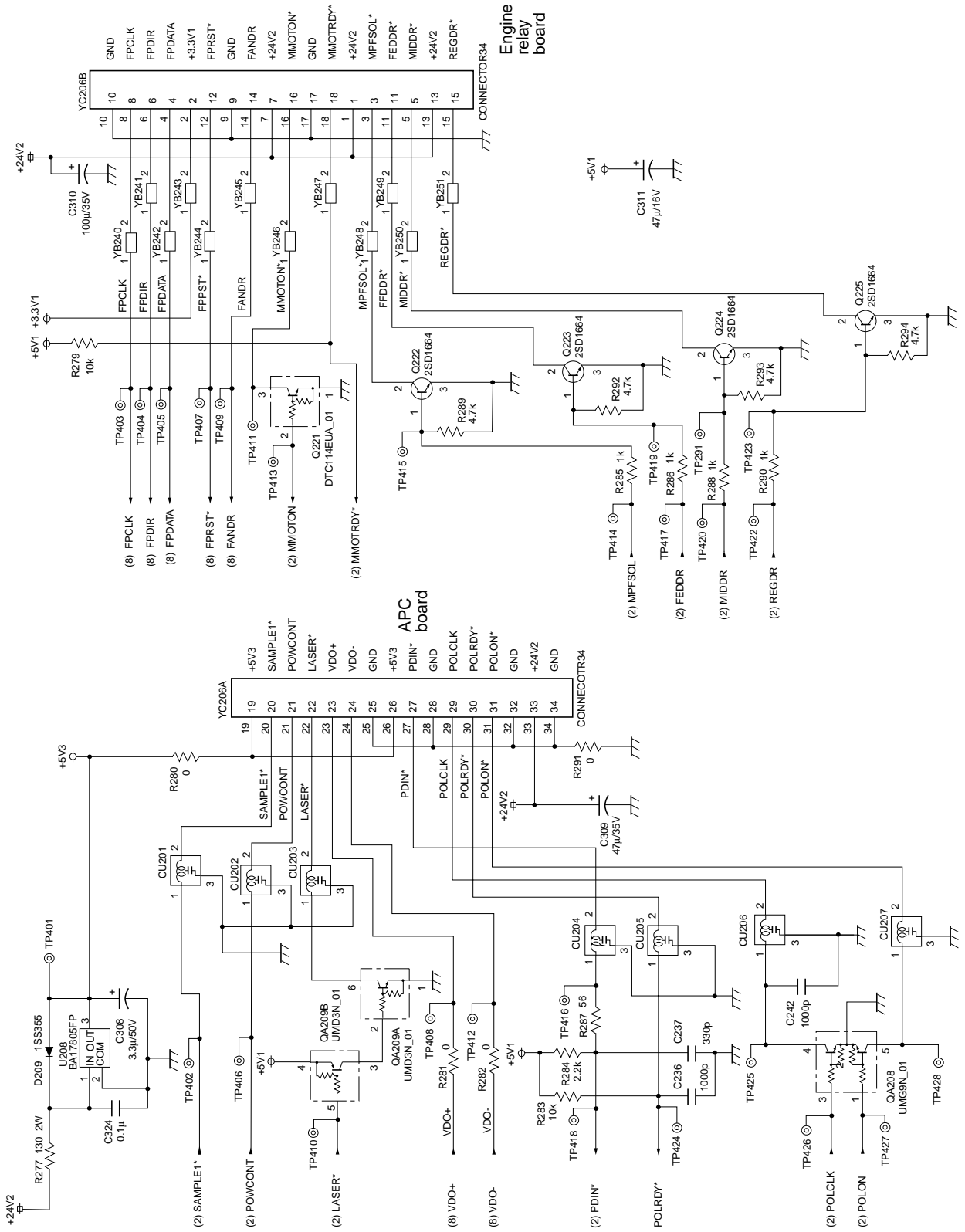

Main board (TK-777) 1/12

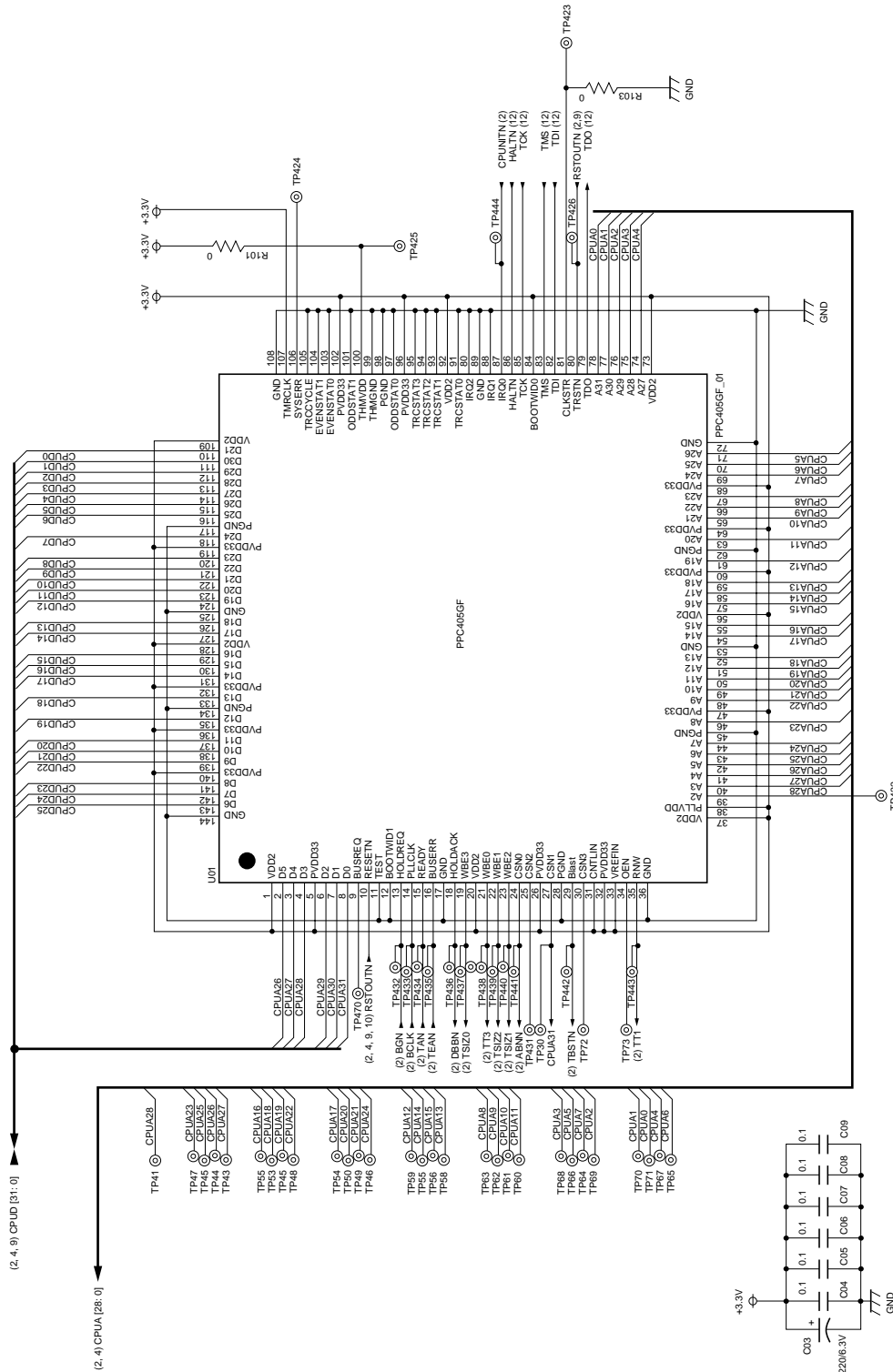

Main board (TK-777) 2/12

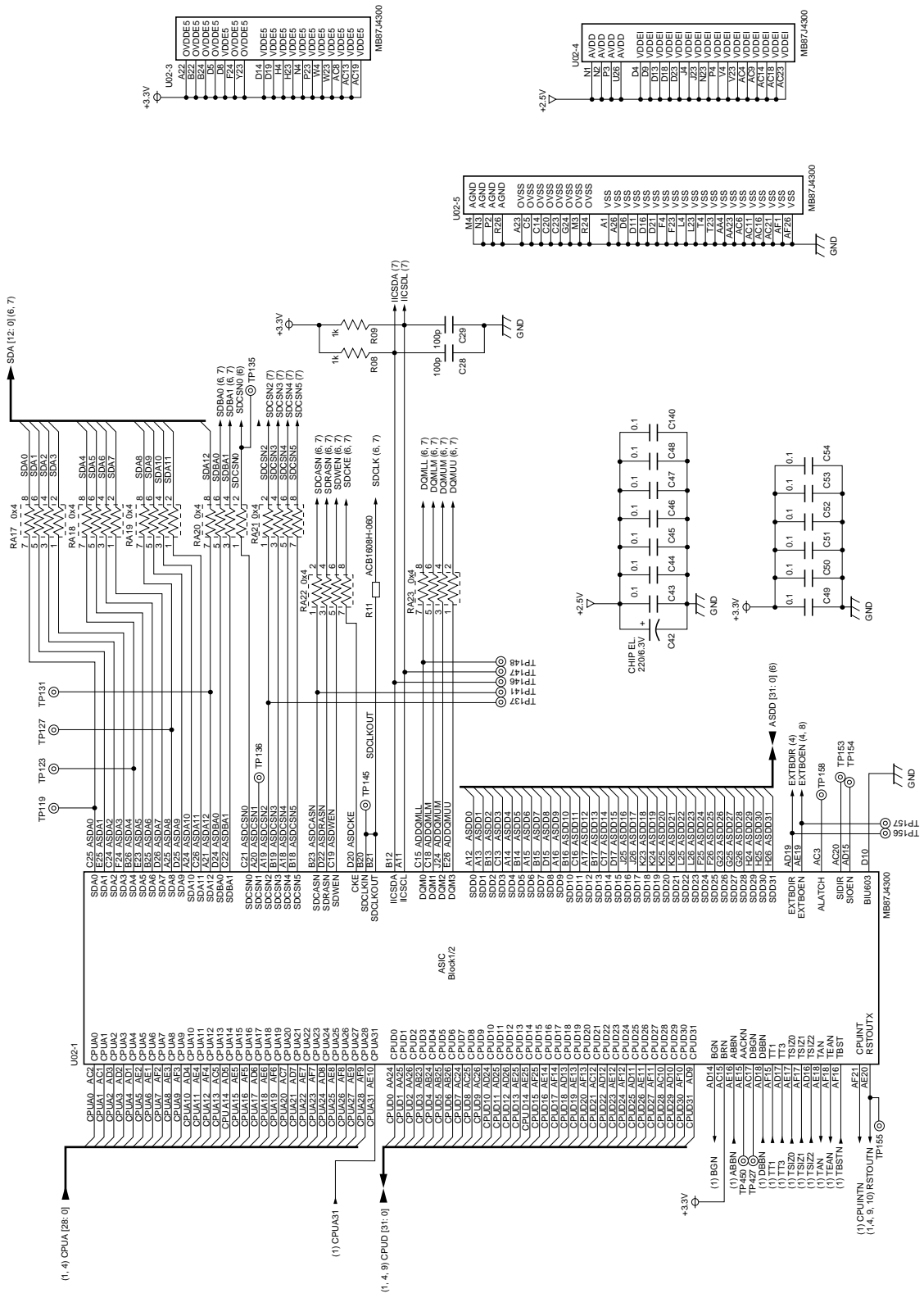

Main board (TK-777) 3/12

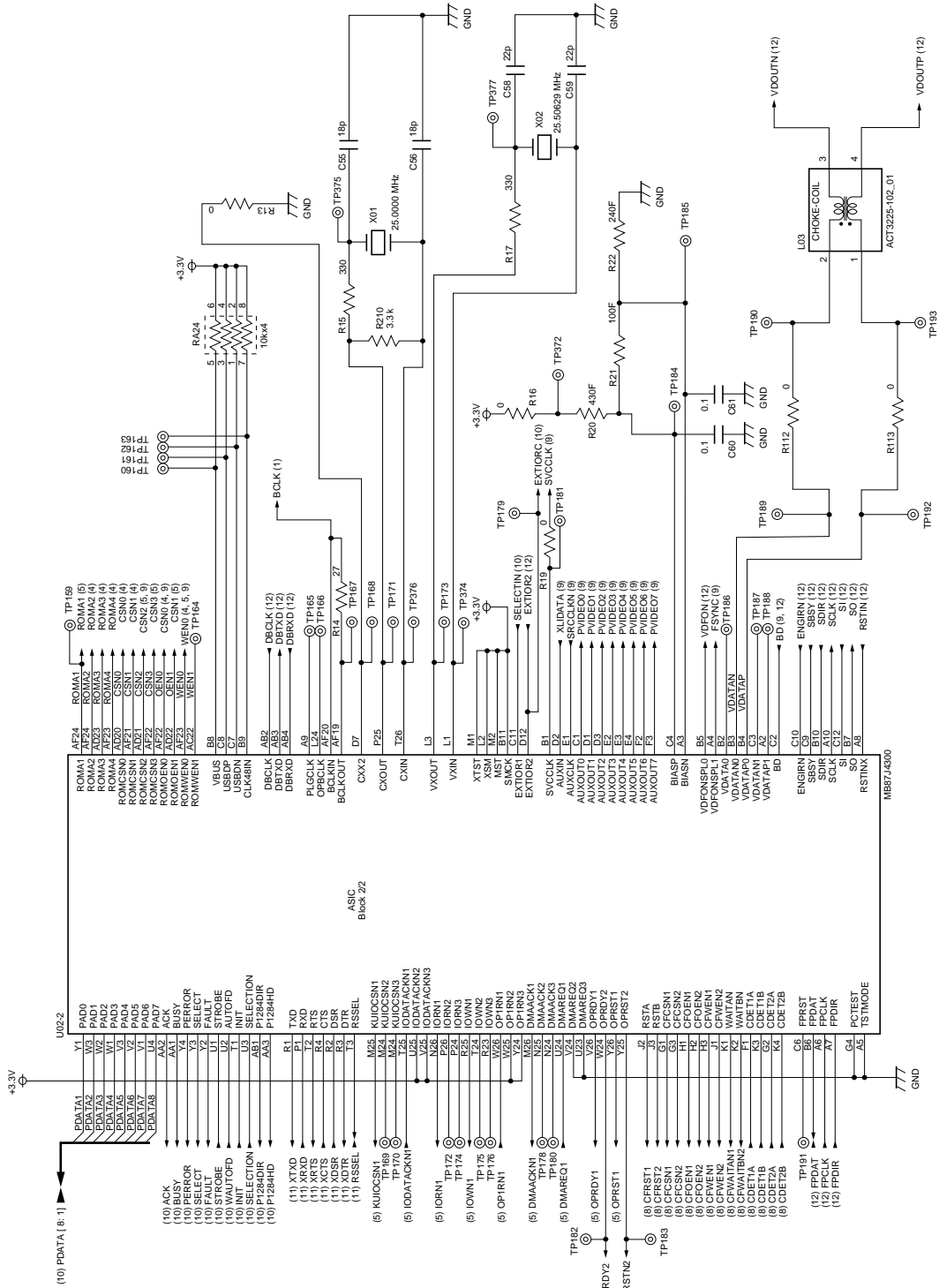

Main board (TK-777) 4/12

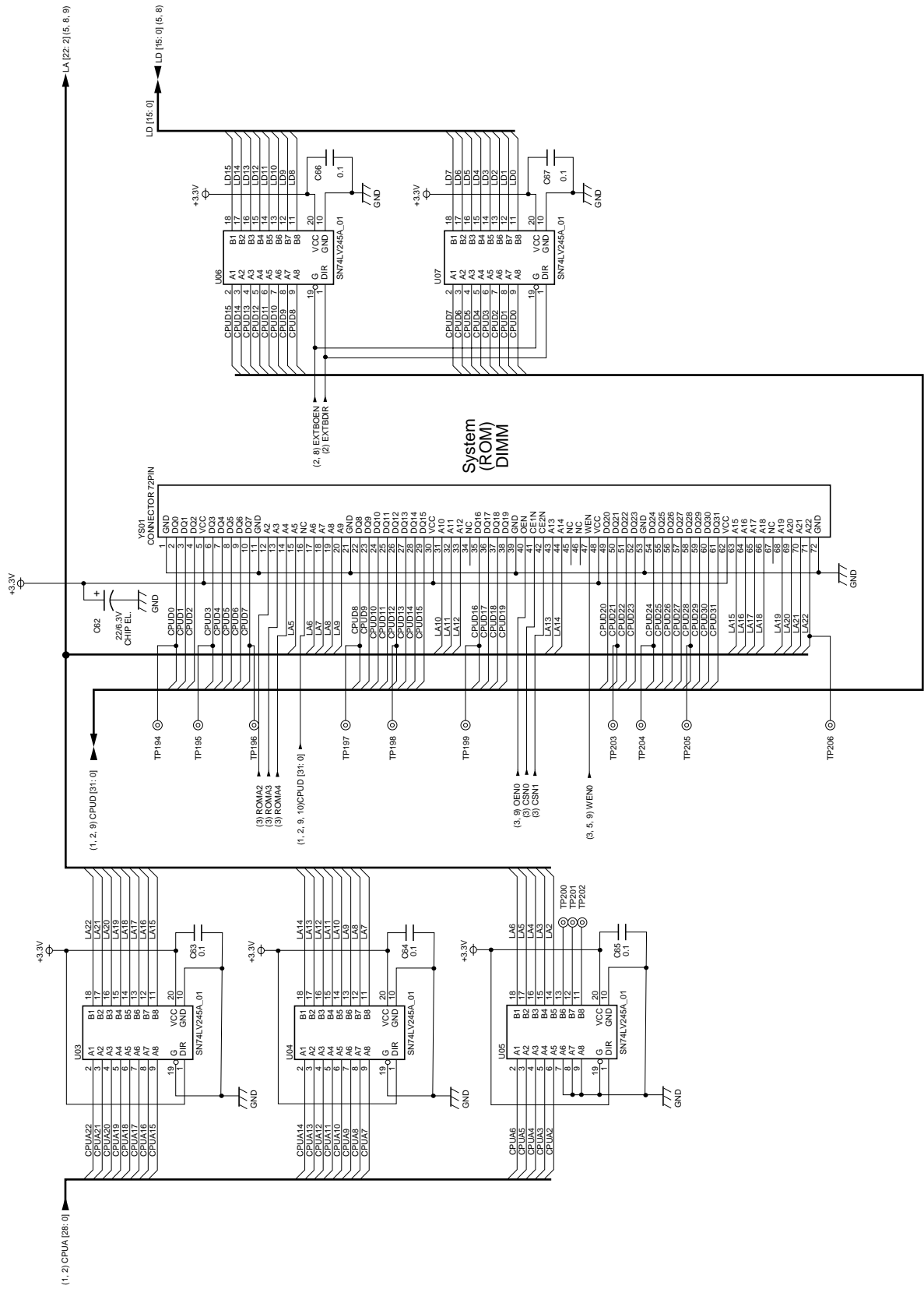

Main board (TK-777) 6/12

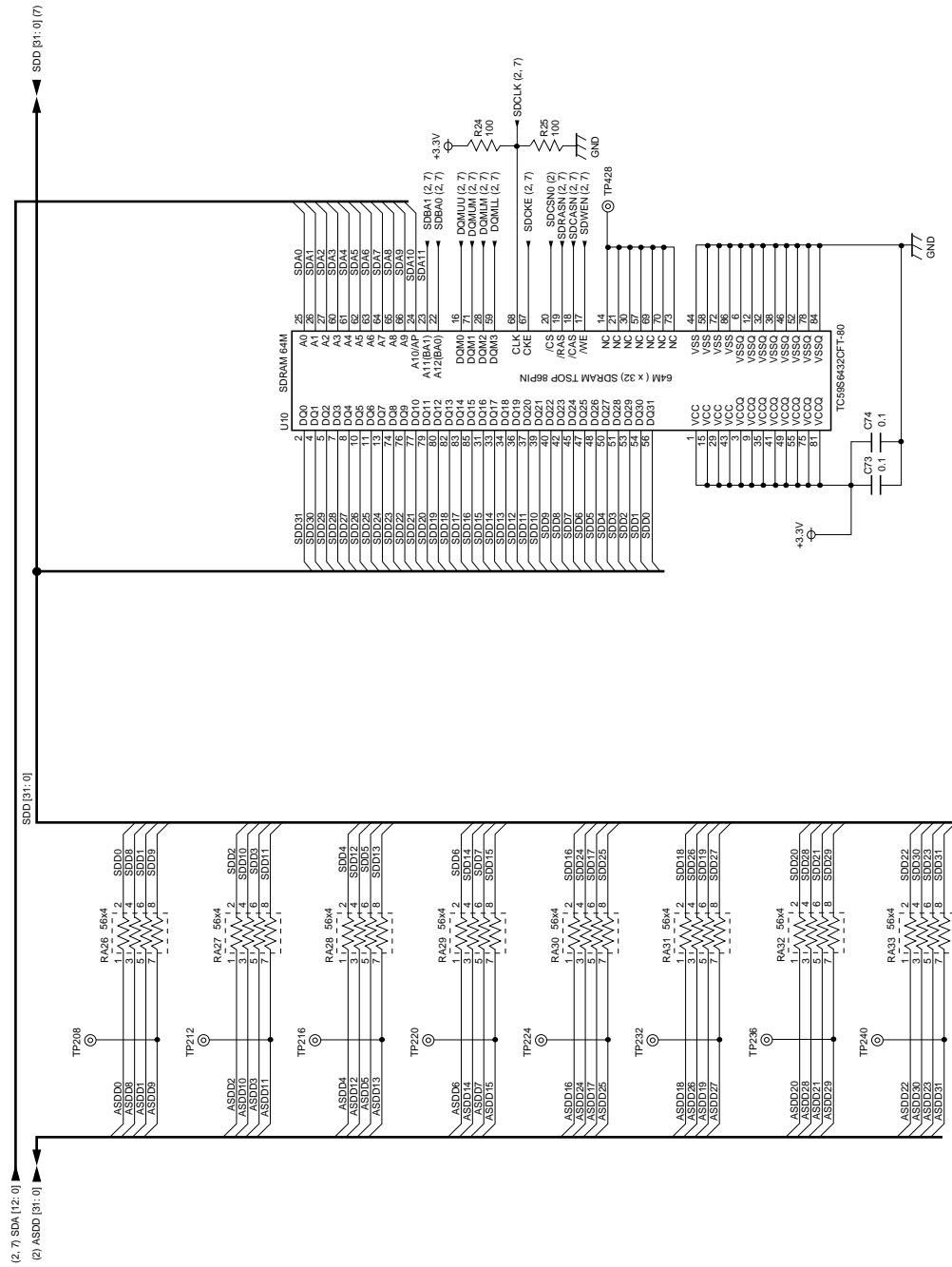

Main board (TK-777) 9/12

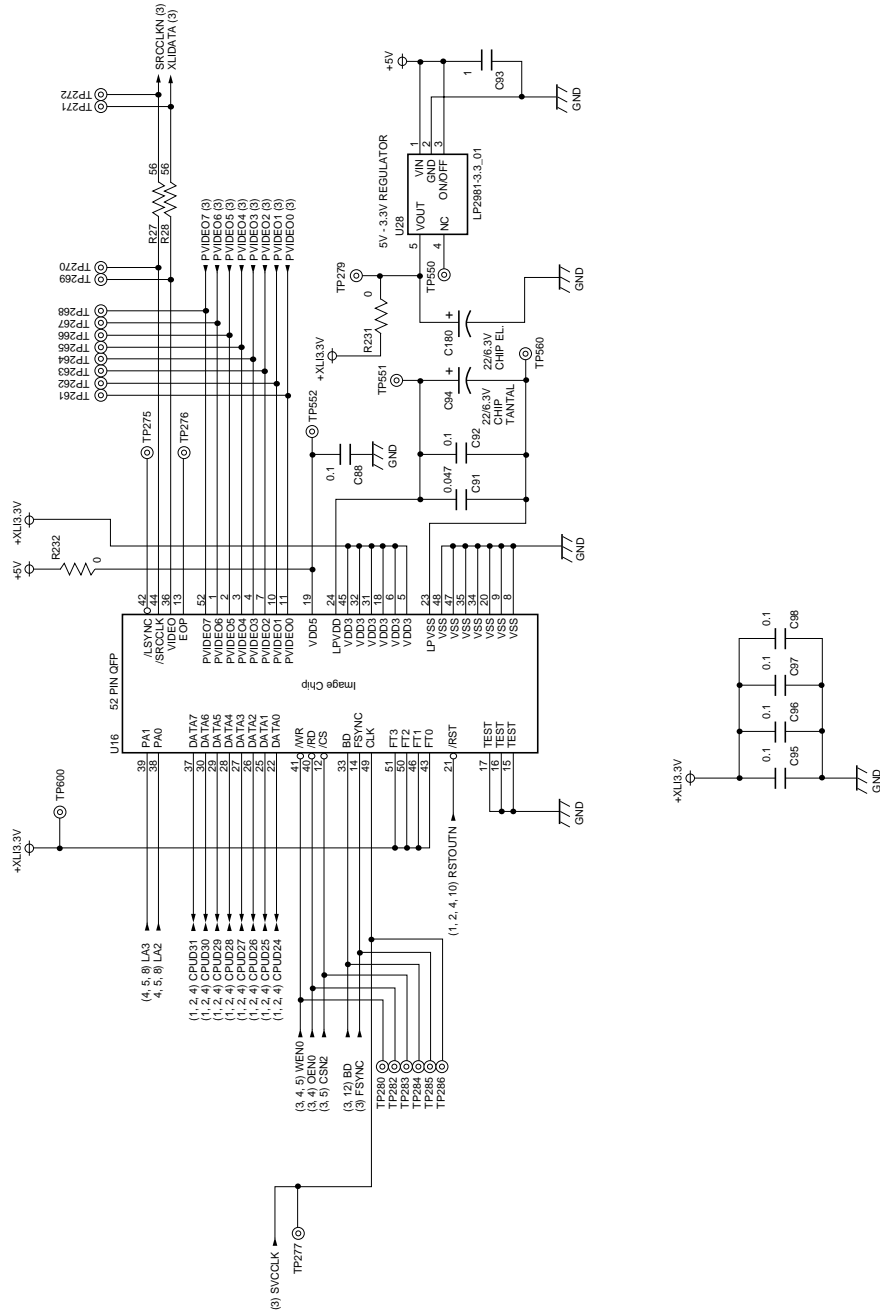

Main board (TK-777) 11/12

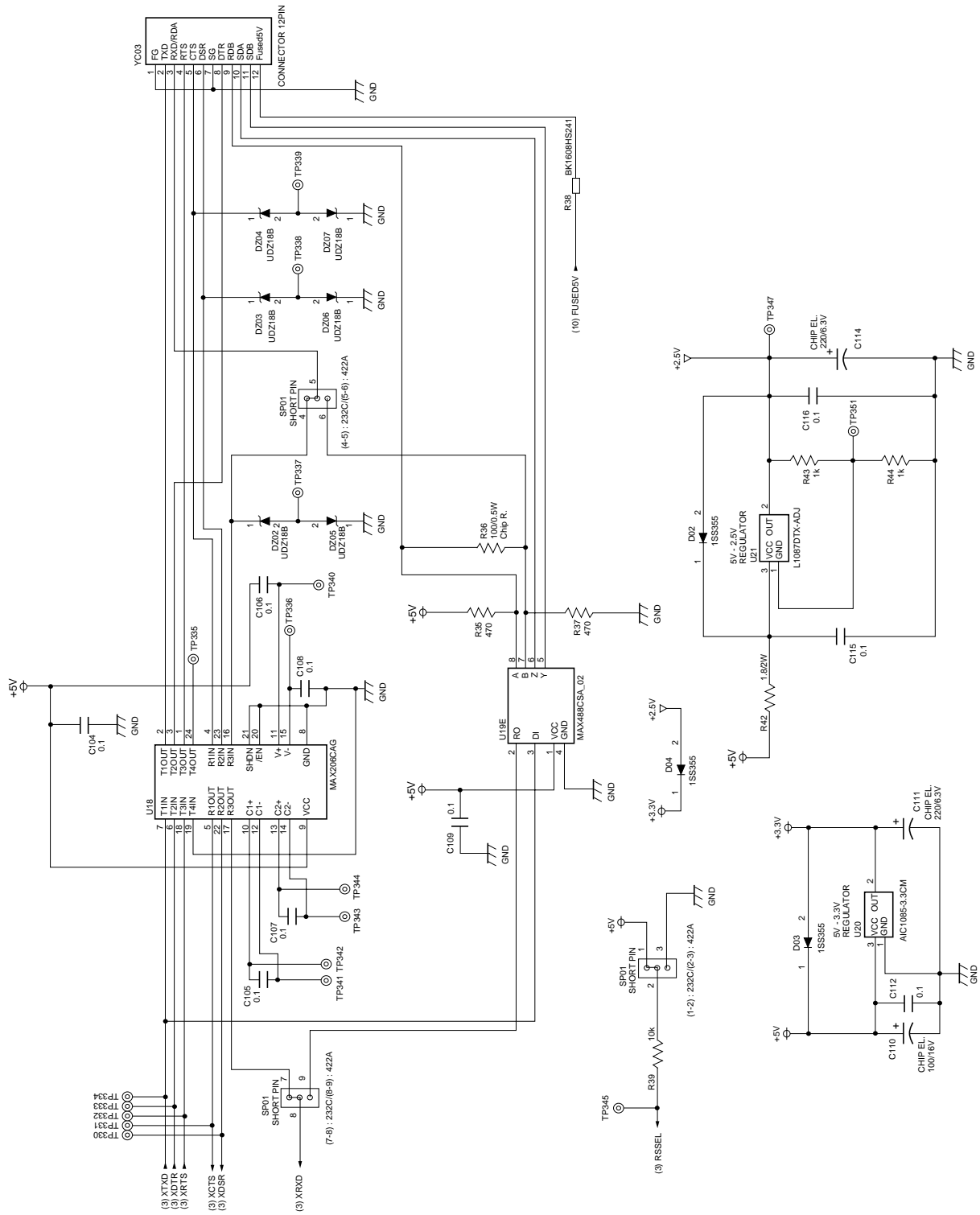

Main board (TK-777) 12/12

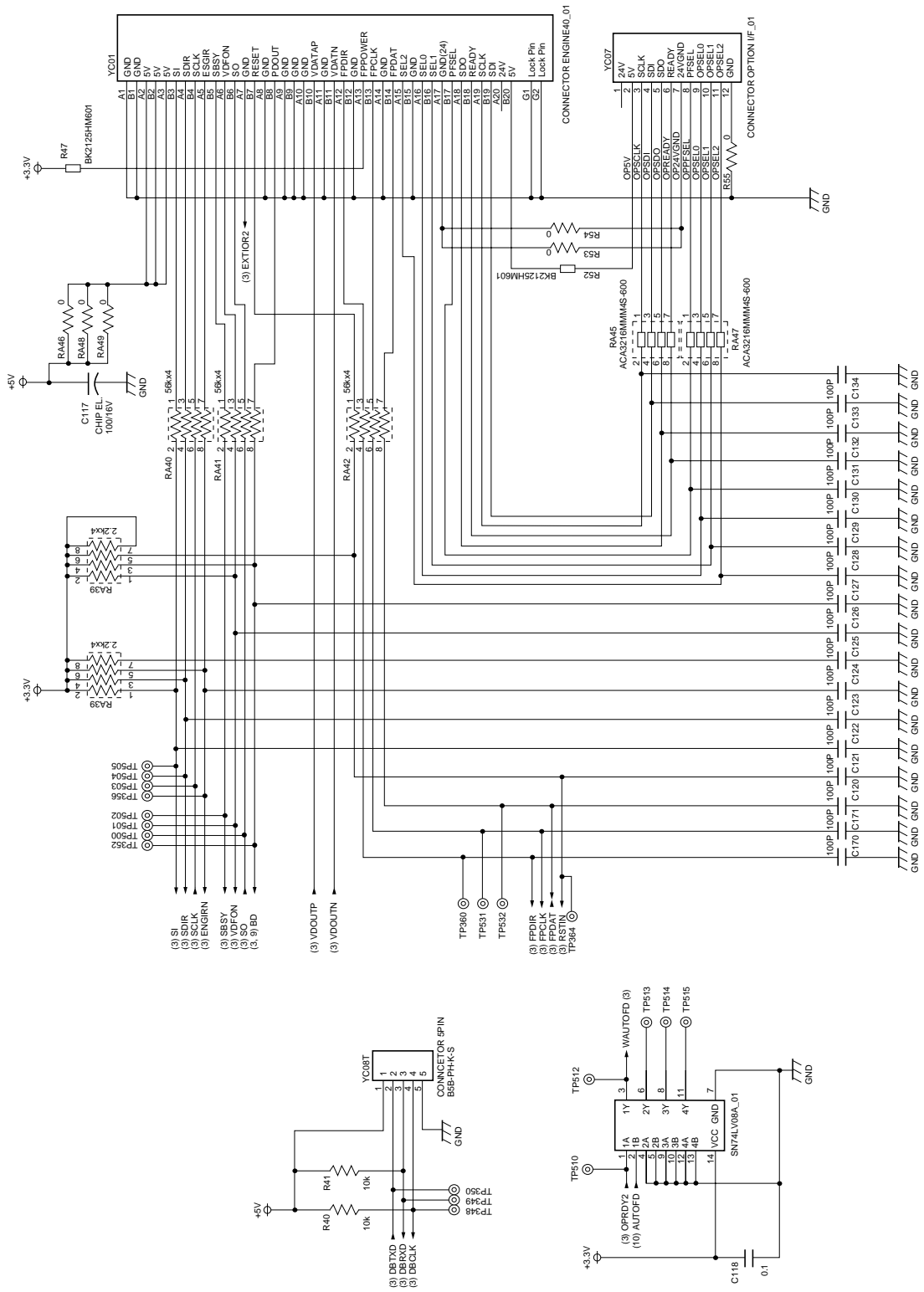

Main board (TK-858) 3/12

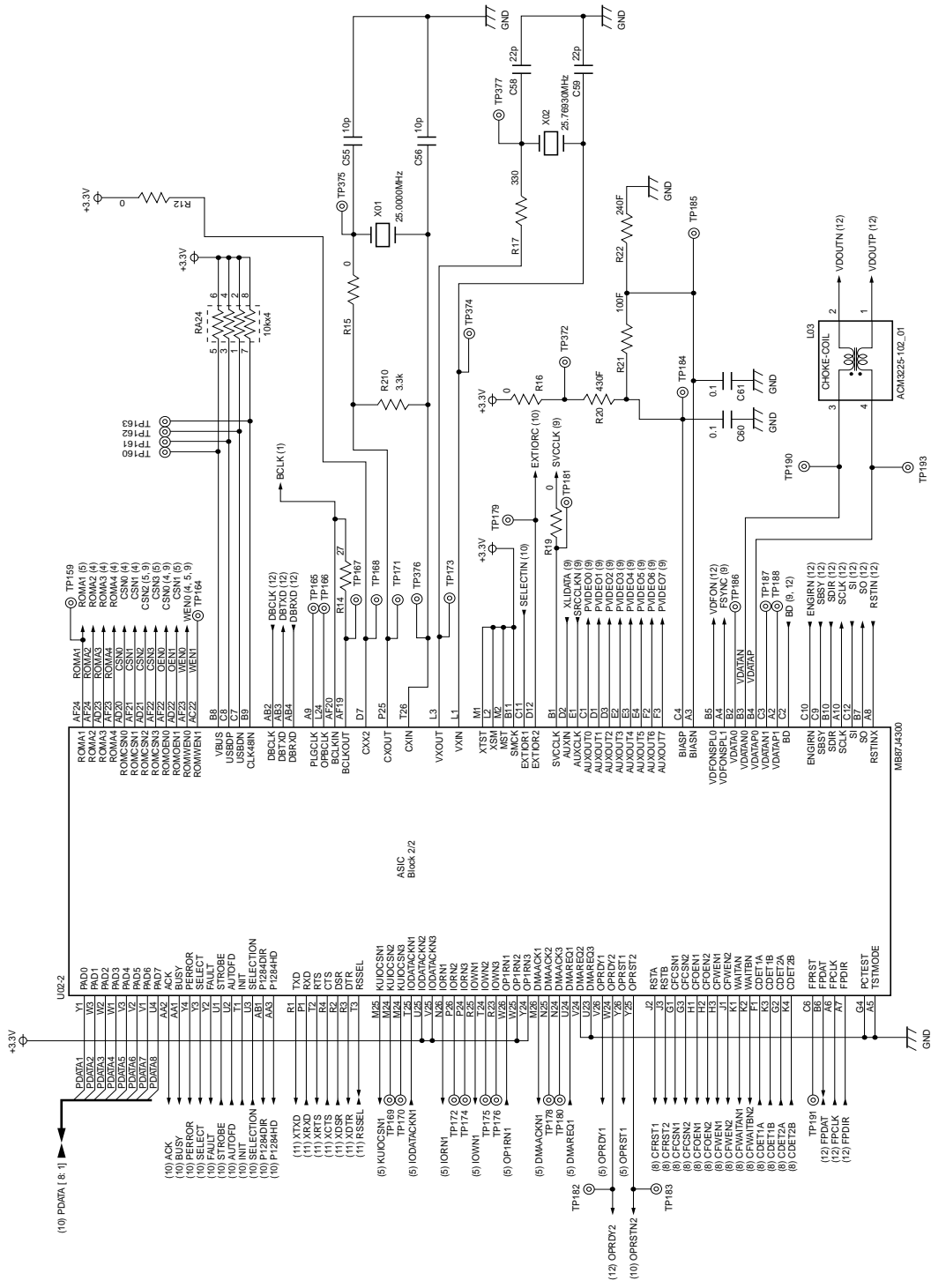

Main board (TK-858) 6/12

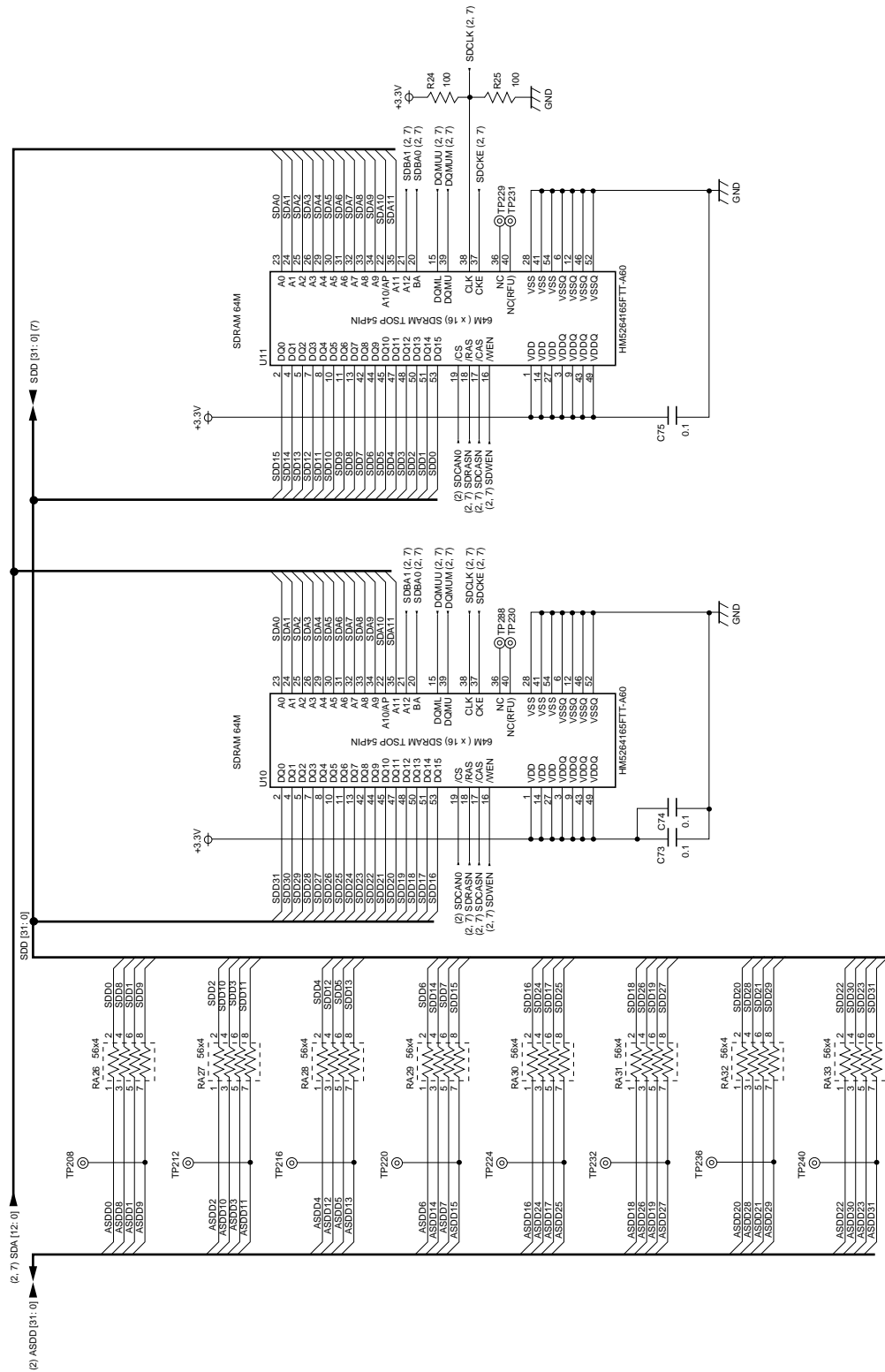

Main board (TK-858) 7/12

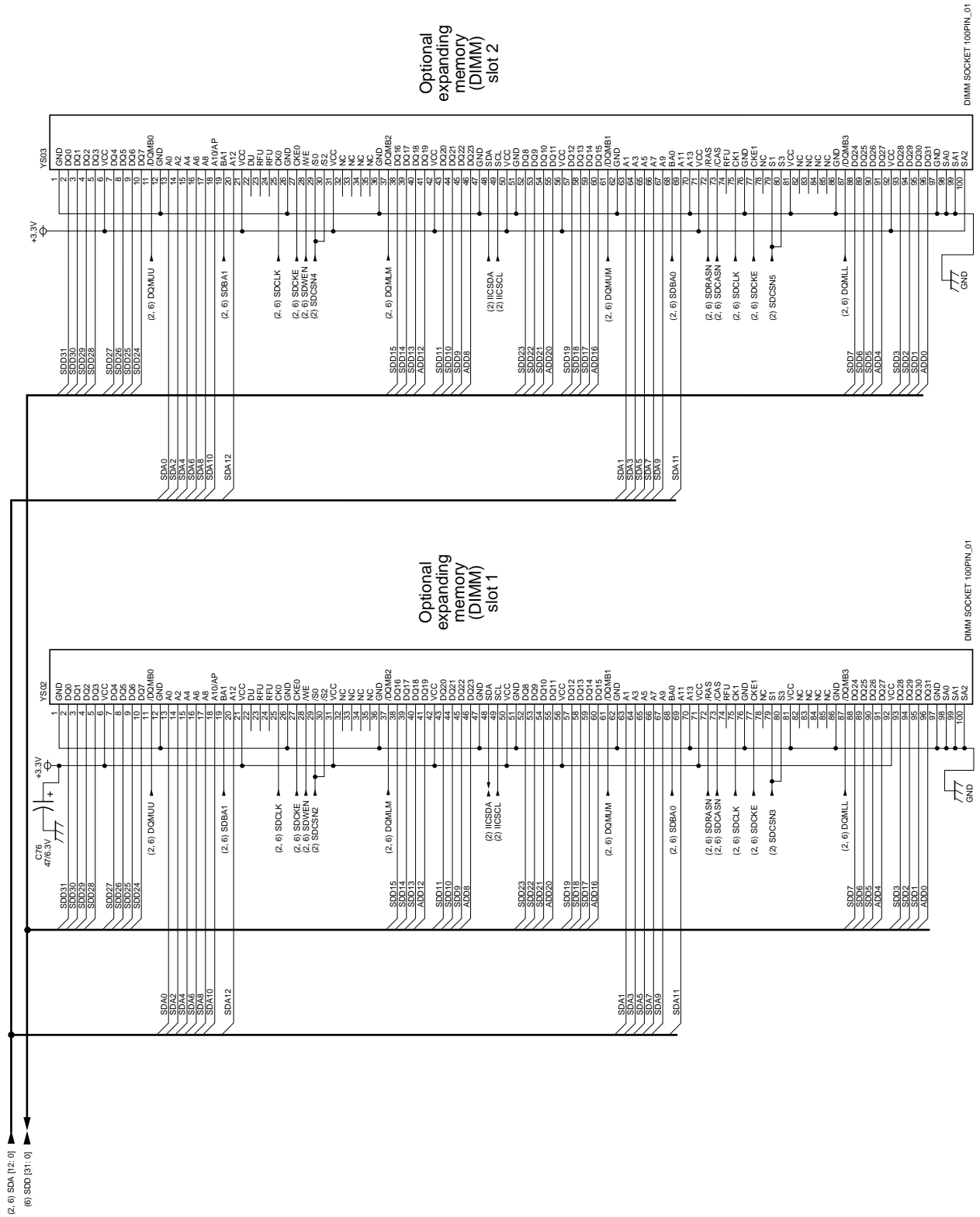

Main board (TK-858) 8/12

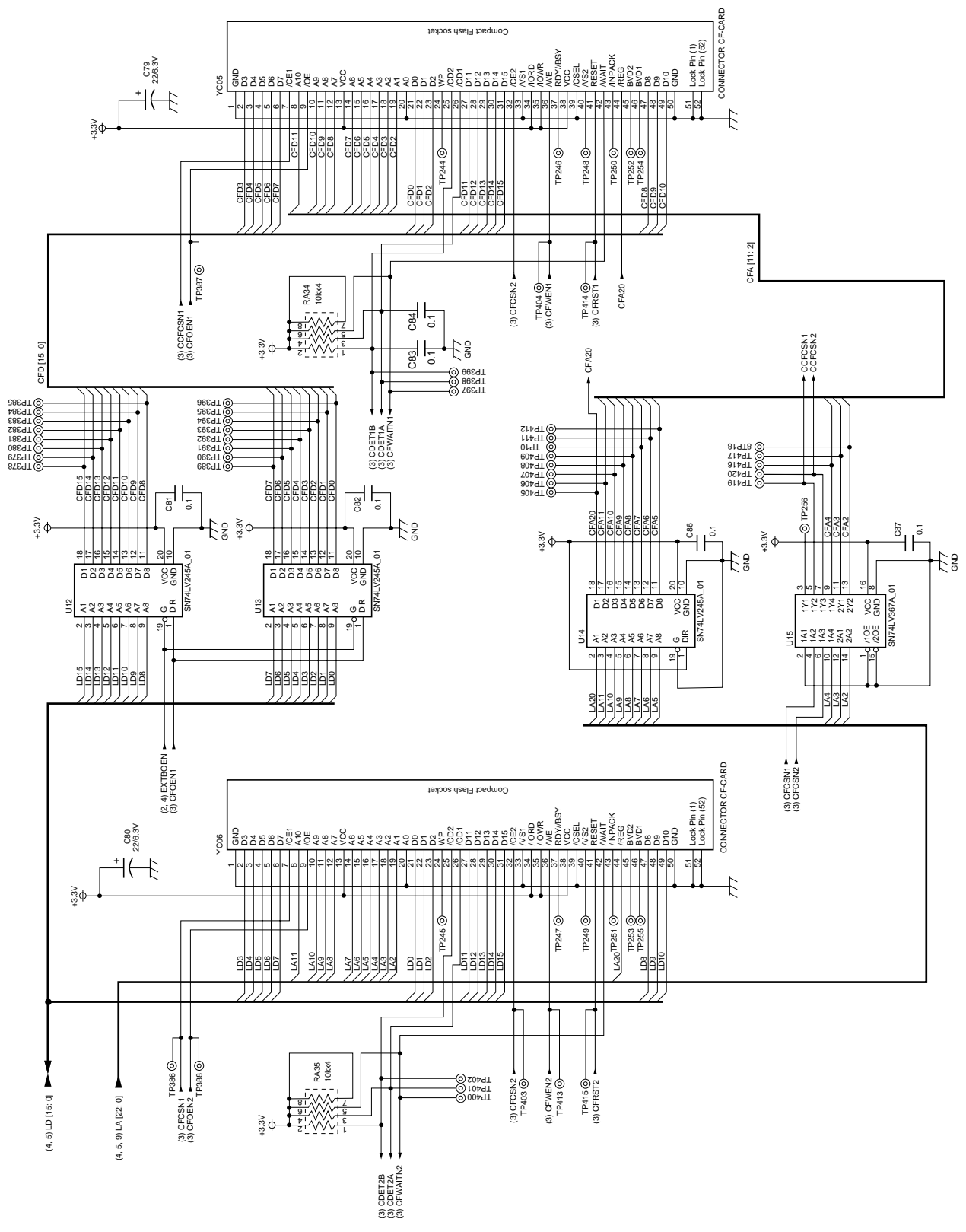

Main board (TK-858) 9/12

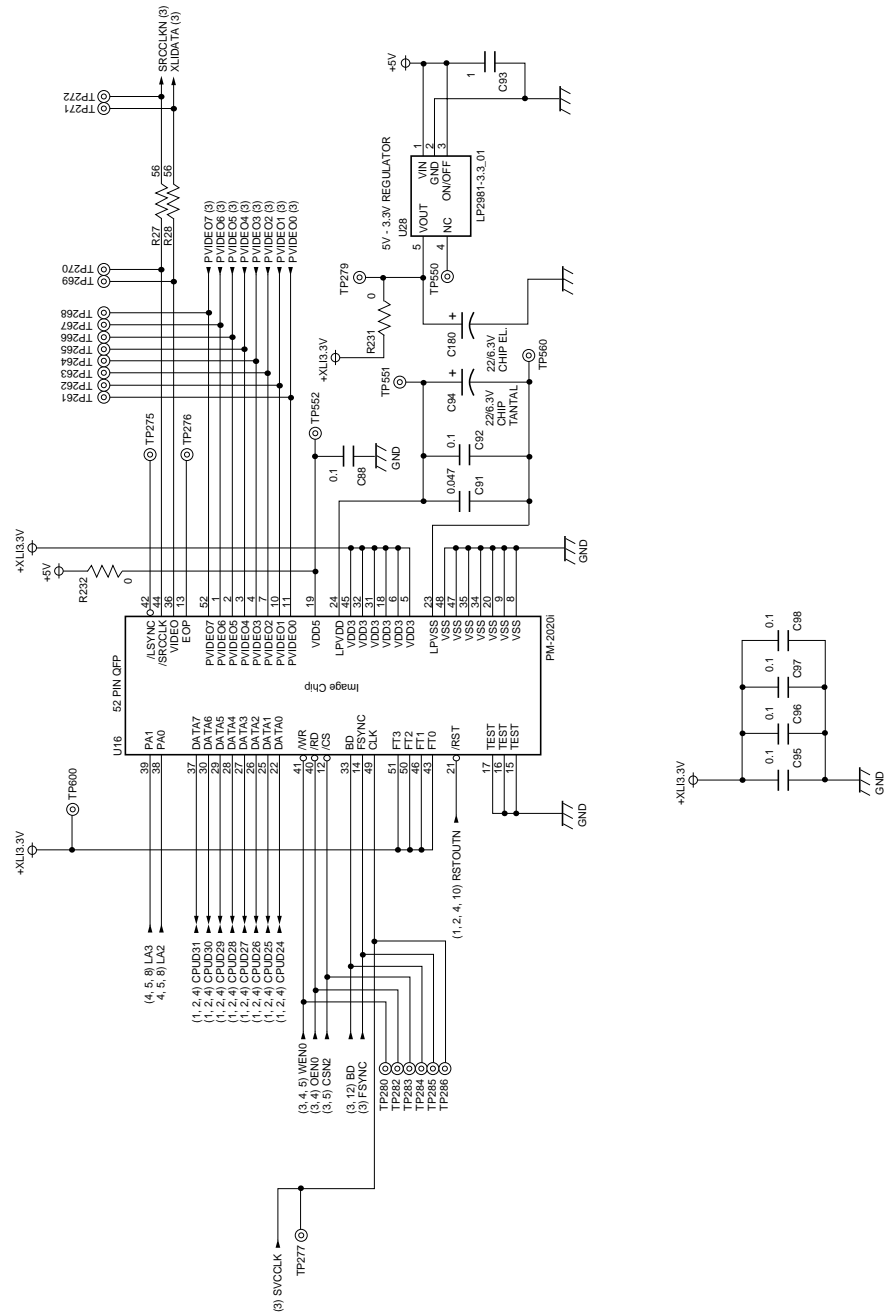

Main board (TK-858) 10/12

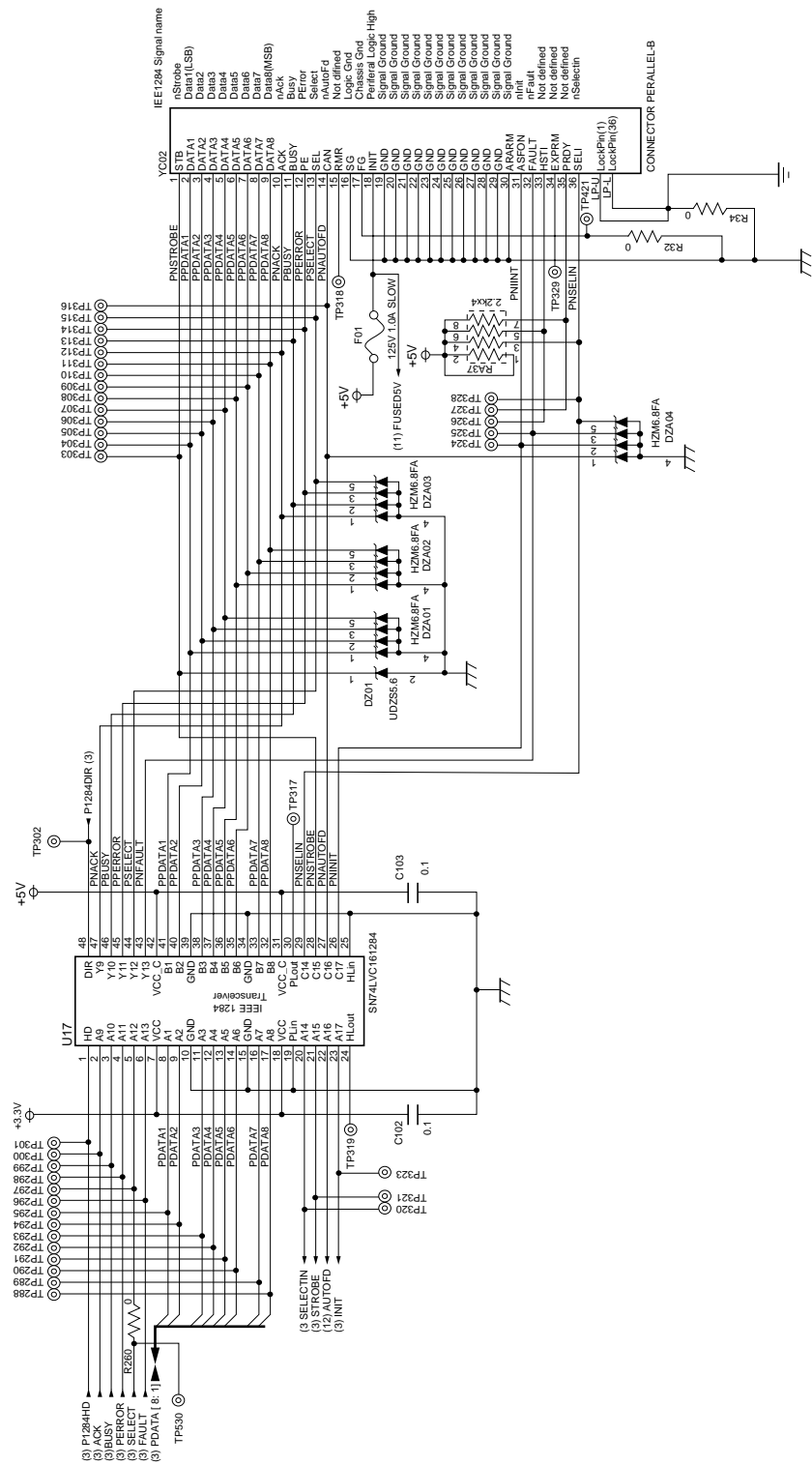

Main board (TK-858) 11/12

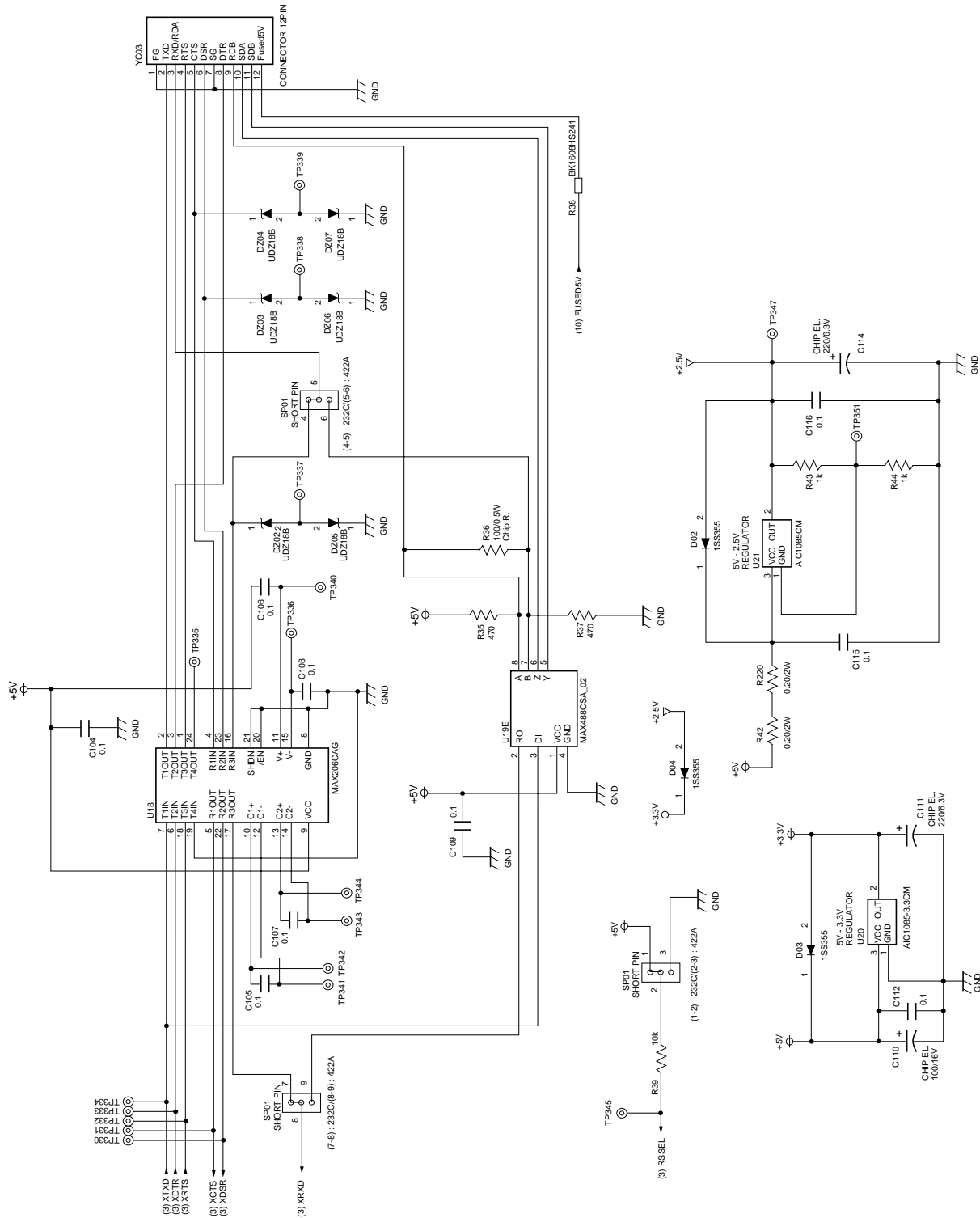

Main board (TK-858) 12/12

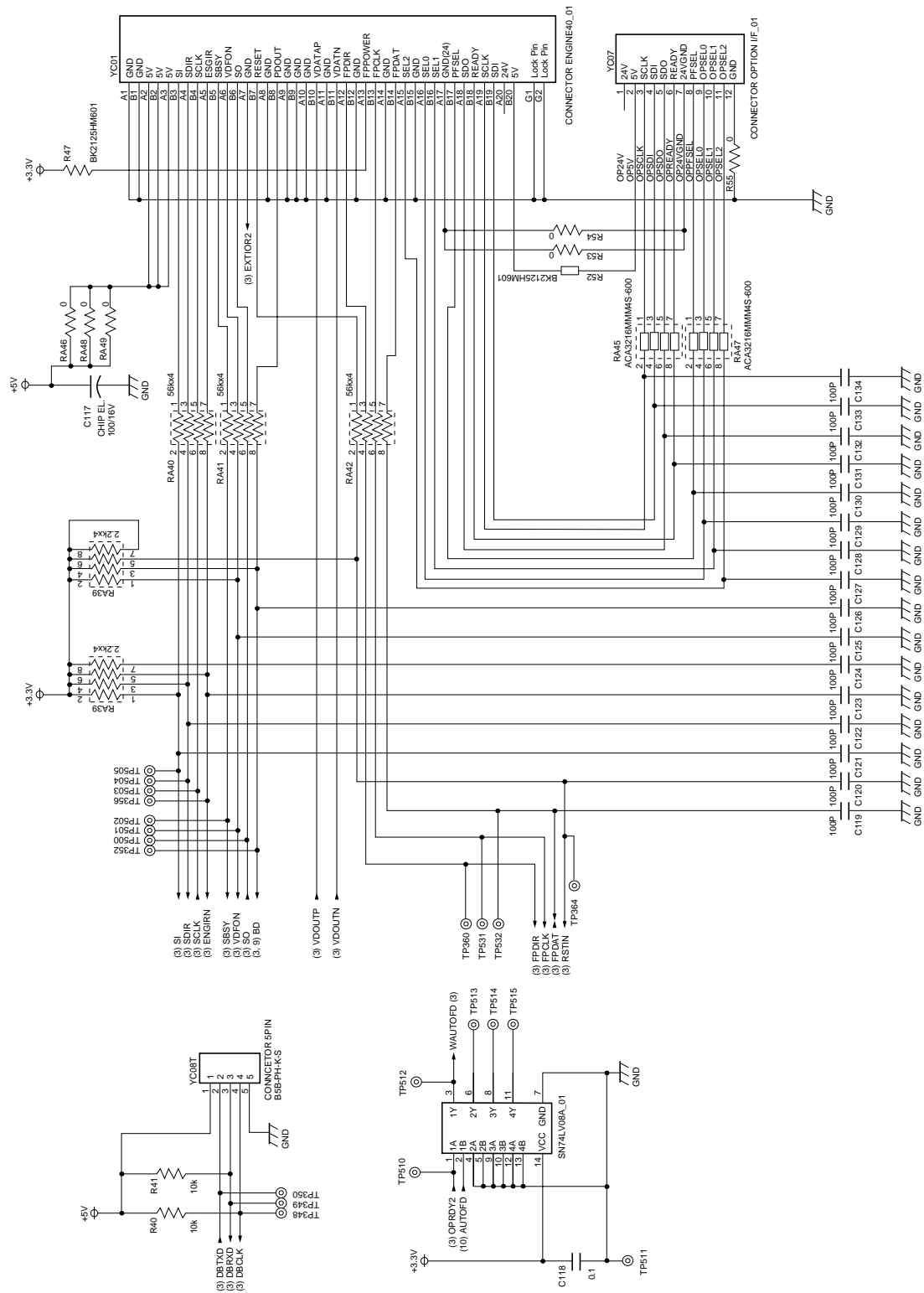

Power supply unit (120 V AC model, Sanken®)

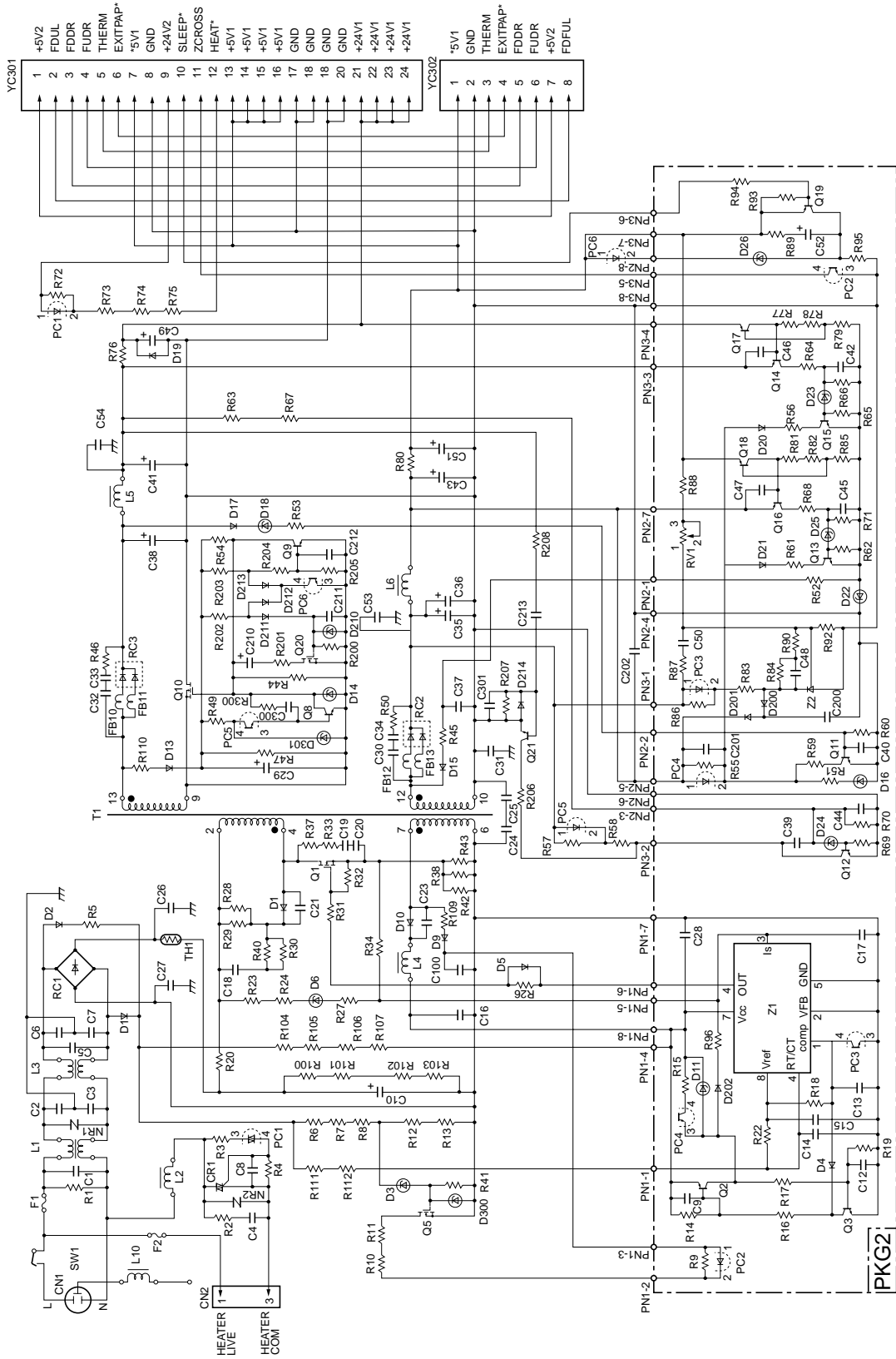

Power supply unit (220 - 240 V AC model, Sanken®)

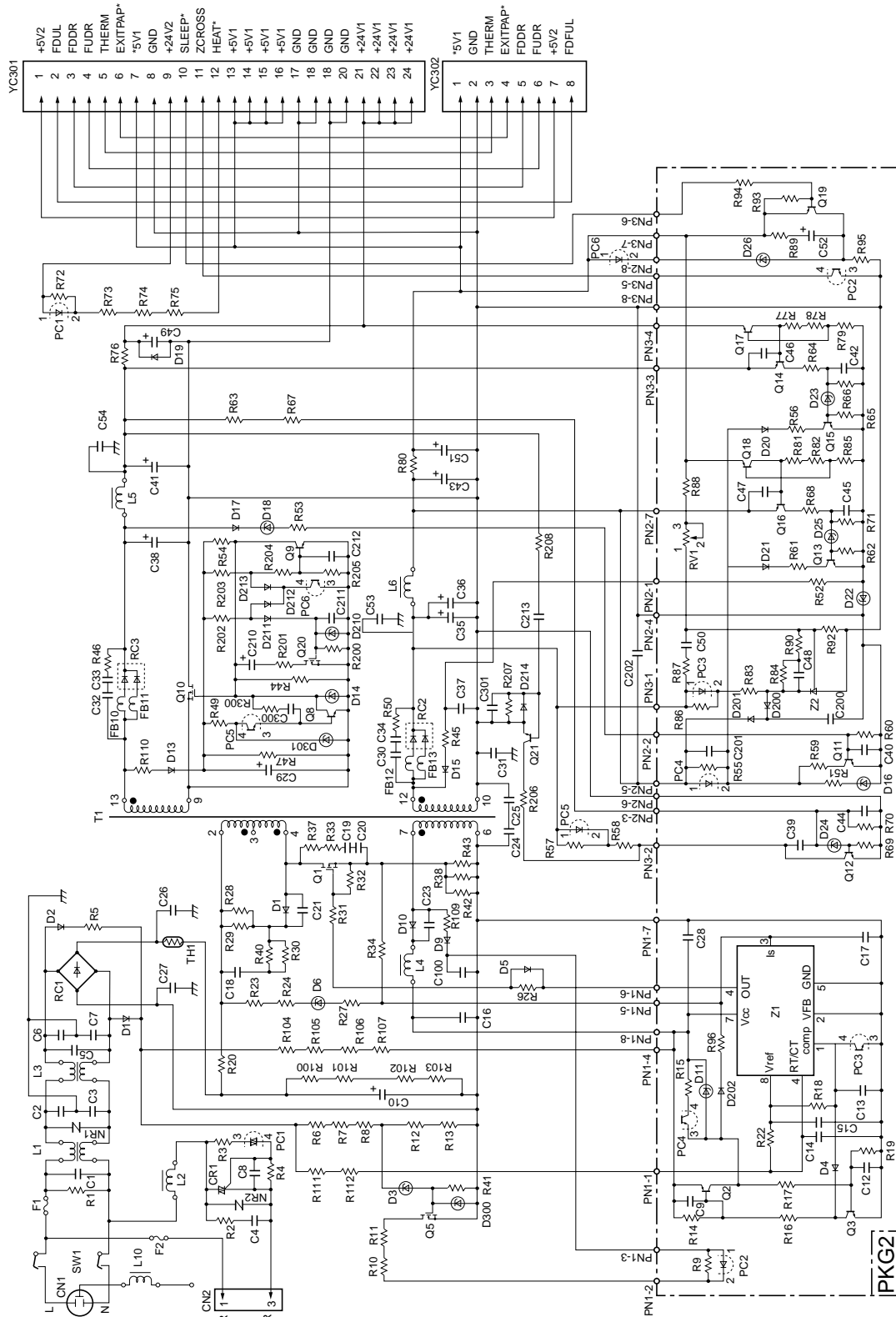

Appendix B S t a t u s P a g e

Appendix B Contents

- Status page B-3
 - Printing the service status page B-3
 - Service information on the status page B-4
 - Details of service information B-4

Status page

The printer can print two different types of the status page—the user (normal) status page and the service status page. This section exclusively describes information obtainable with the service status page. For information on the user (normal) status page, refer to the printer's *User's Manual*.

Information on the service page include various settings for the printer, service statistics, etc. To print a service status page, proceed as follows:

Printing the service status page

To print a service status page, using the MENU key. Or, have a PC running MS-DOS and proceed as follows:

1. Connect the printer to the PC via the parallel interface.
2. Ensure that the printer is ready to print.
3. At the DOS prompt, type:

```
echo !R! STAT 1; EXIT; >lpt1:
```

The service status page is printed. (If you omit '1,' a user status page is printed.)

Service information on the status page

An example of the service status page is shown below. (Note the details born by status page my differ from a firmware version to another.) Most of the service information is located under *Service information*.

Most of these service information on the status page are alphanumerically-coded. Each item is explained next page.

Details of service information

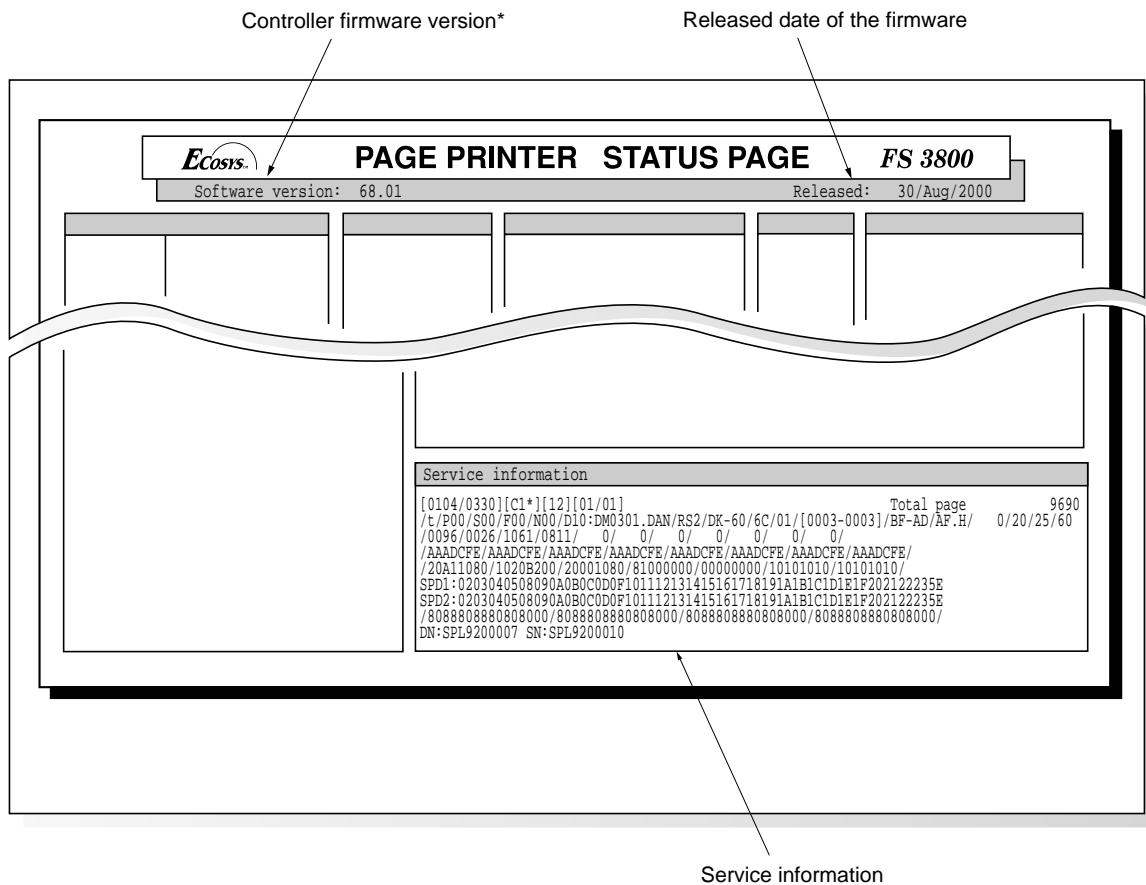

Service information	
[0104/0330][C1][12*][01/01]	Total page 9690
① ② ③ ④	⑤
/t/P00/S00/F00/N00/D10:DM0301.DAN/RS2/DK-60/6C/01/[0003-0003]/BF-AD/AF.H/0/20/25/60	
⑥ ⑦ ⑧ ⑨ ⑩ ⑪ ⑫ ⑬ ⑭ ⑮ ⑯ ⑰ ⑱ ⑲ ⑳ ㉑ ㉒	
/0096/0026/1061/0811/ 0/ 0/ 0/ 0/ 0/ 0/ 0/	
⑳	㉔
/AAADCFE/	
㉕	
/20A11080/1020B200/20001080/81000000/00000000/10101010/10101010/	
㉖	
SPD1:0203040508090A0B0C0D0F101112131415161718191A1B1C1D1E1F202122235E	
㉗	
SPD2:0203040508090A0B0C0D0F101112131415161718191A1B1C1D1E1F202122235E	
㉘	
/8088808880808000/8088808880808000/8088808880808000/8088808880808000	
㉙	
DN:SPL9200007 SN:SPL9200010	
㉚	㉛

Example	Meaning	Description
① [0104/0330]	Mask ROM/Flash ROM version on the engine board	-
② [C1]	Mask ROM version on the LCD controller board (Operator panel)	-
③ [12*]	Boot ROM version, ROM type	“*”: Mask ROM, “-”: Flash ROM
④ [01/01]	Internal use	-
⑤ Total page 9690	Total count page	-
⑥ t/	Internal use	-
⑦ P00/	Parallel interface mode	bit 7= 0: No error with bidirectional communication, 1: Error with bidirectional communication bit 6= 0: No ECP communication, 1: ECP communication had occurred, at least one bit 0 to 5= History of printer parallel port directional communication. 05= Nibble (High-speed), 07= ECP

Example	Meaning	Description
⑧ /S00	Serial interface error	00= Normal, bit 0= Framing error bit 1= Overrun, bit 2= Parity error
⑨ /F00	Operator panel lock (Shown only during locking)	01= Partially locked 02= Fully locked
⑩ /N00	NVRAM error (Shown only if error has occurred)	01= ID error, 02= Version error, 03= Checksum error, 04= NVRAM crash error
⑪ /D10:DM0301.DAN	NVRAM down loading status	00 = Normal (Nothing downloaded), bit0= Font data, bit1= host data, bit2= Macro data, bit3= Program data, bit4= Operator panel message download (shown file name), bit5= OEM data, bit6= Reserved, bit7= Error occurred
⑫ /RS2	Serial interface mode	RS2= RS-232C
⑬ /DK-60	Drum unit model code	(Shown only set the data at EEPROM on the drum board.)
⑭ /6C	Drum sensitivity	-
⑮ /01	Calibration table settings	Hexa decimal (FRPO I4)
⑯ / [0003-0003]	Option unit equipment	The first 2 byte: bit0= MP tray, bit1 to 6= Paper feeder (5 and 6 are not supported.), bit7= Duplexer, bit8= Bulk paper feeder, bit9= Envelope feeder, bit10 to 15= Reserved. The second 2 byte: bit0 =Face-up output tray, bit1= Face-down output tray, bit2= Bulk paper stacker. bit3= Sorter, bit4 to 15= Reserved.
⑰ /BF-AD	Threshold level for “MK replace/warning” message display	(Shown only with MICR model)
⑱ /AF.H	Average print coverage (total)	Two digits for integer part; one digit for decimal; unit is in percent

Example	Meaning	Description
⑲ /0	Operator panel message language	PMSG command settings shown by decimal.
⑳ /20	Toner capacity	Number of pages shown by decimal (× 1000 pages)
㉑ /25	The present temperature	0 to 100 °C, When if “-” shows, the temperature/humidity sensor is abnormal.
㉒ /60	The present humidity	55 to 90 %, step by 5%
㉓ /0096/0026/1061 /0811	Printing area	/Top margin/Left margin/Page length/Page width/, Inches+ ¹ / ₁₀₀ inches (FRPO L1/L2) in ¹ / ₆₀₀ inch
㉔ / 0/ 0/ 0 / 0/ 0/ 0 / 0	Left margin offset for paper source (MP tray/Printer’s cassette/Top paper feeder/Middle feeder/Bottom feeder/Envelope feeder/Duplexer)	
㉕ /AAADCFE/AAADCFE /AAADCFE/AAADCFE /AAADCFE/AAADCFE /AAADCFE/AAADCFE	Life counter for each option units	Paper feeder4/Duplexer/Bulk paper feeder/Bulk paper stacker/Sorter
㉖ /20A11080/1020B200 /20001080/81000000 /00000000/10101010 /10101010	Media type settings	Detailed media type settings 1 to 28. (14 to 20 are reserved and fixed to setting “0x00”.)
㉗ SPD1:02030405...	SPD (slot1)	-
° SPD2:02030405...	SPD (slot2)	-
㉙ /8088808880808000 /.....	Engine Parameter information	Hexadecimal, 32 bytes (64 digits)
㉚ DN:SPL92000007	Serial number for the drum	-
㉛ SN:SPL92000010	Serial number for the printer	-

Appendix C I n t e r f a c e

Appendix C Contents

Parallel interface	C-3
Selecting the parallel interface mode	C-3
Parallel interface pin assignment	C-4
Parallel interface signals	C-5
Serial interface	C-6
RS-232C interface voltage levels	C-6
Connector configurations	C-6
Protocol	C-7
RS-232C - For computers with a DB-9 connector	C-7
RS-232C - For computers with a DB-25 connector	C-7

Parallel interface

The printer uses a bidirectional parallel interface for high-speed data transmission for the host computer. This interface includes the buffers which are compatible with the IEEE 1284 standards. The parallel interface provides support for the ECP and nibble modes in this standards. The parallel interface mode can be changed by commanding Prescribe commands on a PC.

Selecting the parallel interface mode

To change the parallel interface mode, a PC running MS-DOS is needed. Connect the printer to the PC via the parallel interface. Then, at the DOS prompt, type a FRPO O0 (the letter O and the number zero) command as follows depending on the desired parallel mode:

To set the parallel interface mode...	Type at the DOS prompt...
Normal	<code>echo !R! FPRO O0, 0; EXIT;>lpt1:</code>
High-speed	<code>echo !R! FPRO O0, 1; EXIT;>lpt1:</code>
Nibble*	<code>echo !R! FPRO O0, 5; EXIT;>lpt1:</code>
Automatic	<code>echo !R! FPRO O0, 70; EXIT;>lpt1:</code>

*: Factory-set default.

Parallel interface pin assignment

The pins of the parallel interface connector carry the signals listed below. The function for each signal is detailed on the following page.

No.	Terminal	Signal	No.	Terminal	Signal
1	nStrobe	(STBIN1/2*)	19	Ground	GND
2	Data1	(PAD0)	20	Ground	GND
3	Data2	(PAD1)	21	Ground	GND
4	Data3	(PAD2)	22	Ground	GND
5	Data4	(PAD3)	23	Ground	GND
6	Data5	(PAD4)	24	Ground	GND
7	Data6	(PAD5)	25	Ground	GND
8	Data7	(PAD6)	26	Ground	GND
9	Data8	(PAD7)	27	Ground	GND
10	nAck	(ACKOUT)	28	Ground	GND
11	Busy	(BUSYOUT)	29	Ground	GND
12	PError	(PERROR)	30	Ground	GND
13	Select	(SELECT)	31	nInit	(INIT*)
14	nAutoFd	(AUTOFD*)	32	nFault	(FAULT*)
15	Not defined	NC	33	Not defined	Pull-up (1 k Ω)
16	Logic ground	GND	34	Not defined	NC
17	Chassis ground	GND	35	Not defined	Pull-up (1 k Ω)
18	Peri-logic H	(VCC)	36	nSelect In	(SELECTI*)

Maximum rated current for pin 18 is 500 mA (fused).

Pin 18 can not use pin 12 (+5V) of serial connector RS-232C at the same time.

Parallel interface signals

The following table provides details for the signals used on the printer's parallel interface. Note descriptions in [] are for high-speed mode of the parallel interface.

Signal	Meaning
Strobe* [nStrobe] (Pin 1)	A negative-going Strobe* pulse causes the printer to read and latch the data on the Data 0 [1] to Data 7 [8] signal lines.
Data 0 [1] to Data 7 [8] (Pins 2 to 9)	These eight signals form the data byte sent from the host computer to the printer. Data 7 [8] is the most significant bit and Data 0 [1] is the least significant bit.
Acknowledge* [nAck] (Pin 10)	This signal is returned to the host computer. This negative-going pulse acknowledges the previous character received by the printer. Acknowledge* pulses are sent only when Busy is low.
Busy [Busy] (Pin 11)	This signal is returned to the host computer. This signal is high when the printer is busy and low when it is able to accept more data. Every high-to-low transition is followed by an Acknowledge* pulse.
Paper Empty [PError] (Pin 12)	This signal is returned to the host computer. This signal goes high when the printer runs out of paper.
On-Line [Select] (Pin 13)	This signal is returned to the host computer. This signal is high when the printer is on-line and low when the printer is off-line. It goes low when the upper unit is raised, or when the GO key is pressed to set the printer off-line. <i>Note:</i> The Paper Empty and On-Line signals are not used unless enabled by the FRPO command (O2 parameter).
Auto-Feed [nAutoFd] (Pin 14)	This signal is used in the Epson version of the Centronics interface to receive a carriage return. In high-speed mode, it is used as an interrupt.
+5 V DC (pin 18)	This line is connected to the printer's +5 V DC line (+5 V \pm 0.5 V, 500 mA maximum, fused).
Prime [nInit] (Pin 31)	This signal is used in the standard Centronics interface to enable the computer to reset the printer. It is ignored by the printer.
Error* [nFault] (Pin 32)	When the high-speed parallel line control is on (FRPO O2 = 2), this line returns error status to the host computer.
Auxiliary output 1 (Pin 33)	This signal line is not used.
Power Ready (Pin 35)	This signal is high when the printer's power is on.
Select In [NSelectIn] (Pin 36)	This signal is used in some versions of the Centronics interface to enable the computer to force the printer on-line. In high-speed mode, it is used as an interrupt.

Serial interface

The printer is equipped with a serial interface connector. The device responsible for controlling the serial interface is integrated in the gate array in the controller system. The serial interface supports protocol of RS-232C. A 25-pin D-sub connector is used for the serial interface.

RS-232C interface voltage levels

The voltage levels of the RS-232C signals conform to EIA RS-232C specifications. FALSE is from 3 volts to 15 volts. TRUE is from -3 volts to -15 volts. Voltages between -3 volts and 3 volts are undefined.

Connector configurations

The printer uses a DB-25 connector for the serial interface. Depending on the computer configurations for serial interface, use either of the appropriate configurations.

Signal	Meaning
FG (Pin 1)	This pin is connected directly to the printer frame.
TxD (Pin 2)	This output carries asynchronous data sent by the printer to the computer. It is used mainly in handshaking protocols.
RxD (Pin 3)	This input carries serial asynchronous data sent by the computer to the printer.
RTS (Pin 4)	This output is always held high (above 3 V).
CTS (Pin 5)	Unused.
DSR (Pin 6)	Unused.
SG (Pin 7)	All signals can transmit between the printer and the host computer to send each signals with a signal ground.
+5V (Pin 12)	Power supply for barcode reader. (Maximum 500 mA)
DTR (Pin 20)	This output is used as a buffer nearly-full handshake line. It is held high (above 3 V) when the buffer can accept more data.

Protocol

The serial interface supports the full baud rate of: 1200, 2400, 4800, 9600, and 19200, 38400, 57600 and 115.2 k (bps). For adjusting serial interface parameters including baud rate, parity, etc., refer to printer's *User's Manual*.

RS-232C - For computers with a DB-9 connector

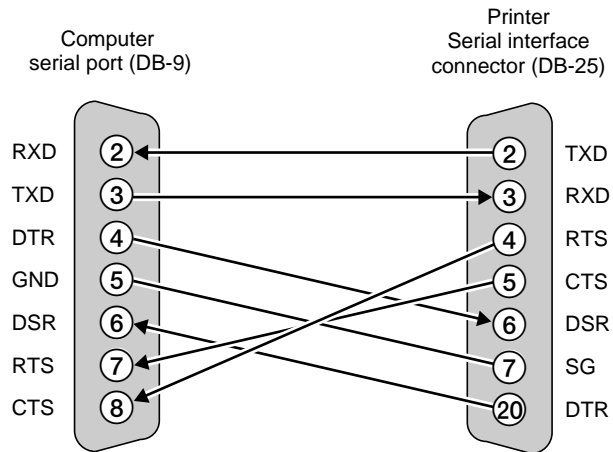

RS-232C - For computers with a DB-25 connector

