



# SERVICE MANUAL

DUAL BAND FM TRANSCEIVER

**IC-24AT**

**IC-24ET**

---

Downloaded by  
RadioAmateur.EU

---

---

---

## INTRODUCTION

This service manual describes the latest service information for the IC-24AT/ET DUAL BAND FM TRANSCEIVER at the time of publication.

VERSION NUMBER	VERSION	MODEL	FREQUENCY RANGE	
			VHF	UHF
#02	U.K.	UK	144~146 MHz	430~440 MHz
#03	Europe	EUR	144~146 MHz	430~440 MHz
#04	Italy	ITA	144~148 MHz	430~440 MHz
#05	U.S.A.	USA	144~148 MHz	440~450 MHz
#07	Australia	AUS	144~148 MHz	430~440 MHz
#09	Asia	SEA	144~148 MHz	430~440 MHz

## DANGER

**NEVER** connect the transceiver to an AC outlet or to a DC power supply that uses more than 16V. This will ruin the transceiver.

**DO NOT** expose the transceiver to rain, snow or any liquids.

**DO NOT** reverse the polarities of the power supply when connecting the transceiver.

**DO NOT** apply an RF signal of more than 20 dBm (100 mW) to the antenna connector. This could damage the transceiver's front end.

## ORDERING PARTS

Be sure to include the following four points when ordering replacement parts:

1. 10-digit order numbers
2. Component part number and name
3. Equipment model name and unit name
4. Quantity required

<SAMPLE ORDER>

1180000550 IC RH5VA37CA-T1 IC-24AT LOGIC UNIT 5 pieces  
8810005720 Screw PH B0 M2 X 20 ZK IC-24AT Rear panel 10 pieces

Addresses are provided on the inside back cover for your convenience.

## REPAIR NOTE

1. Make sure a problem is internal before disassembling the transceiver.
2. **DO NOT** open the transceiver until the transceiver is disconnected from its power source.
3. **DO NOT** force any of the variable components. Turn them slowly and smoothly.
4. **DO NOT** short any circuits or electronic parts. An insulated tuning tool **MUST** be used for all adjustments.
5. **DO NOT** keep power ON for a long time when the transceiver is defective.
6. **DO NOT** transmit power into a signal generator or sweep generator.
7. **ALWAYS** connect a 30 dB~40 dB attenuator between the transceiver and a deviation meter or spectrum analyzer when using such test equipment.
8. **READ** the instructions of test equipment thoroughly before connecting the equipment to the transceiver.



# TABLE OF CONTENTS

<b>SECTION 1</b>	<b>SPECIFICATIONS</b> .....	1-1
<b>SECTION 2</b>	<b>INSIDE VIEWS</b> .....	2-1
<b>SECTION 3</b>	<b>CIRCUIT DESCRIPTION</b> .....	3-1~6
3-1	VHF RECEIVER CIRCUITS .....	3-1
3-2	UHF RECEIVER CIRCUITS .....	3-2
3-3	VHF TRANSMITTER CIRCUITS .....	3-2
3-4	UHF TRANSMITTER CIRCUITS .....	3-3
3-5	PLL CIRCUITS .....	3-3
3-6	LOGIC CIRCUITS .....	3-4
3-7	POWER SUPPLY CIRCUITS .....	3-6
<b>SECTION 4</b>	<b>MECHANICAL PARTS AND DISASSEMBLY</b> .....	4-1~2
4-1	FRONT PANEL .....	4-1
4-2	REAR PANEL .....	4-2
4-3	ACCESSORIES .....	4-2
<b>SECTION 5</b>	<b>PARTS LIST</b> .....	5-1~9
<b>SECTION 6</b>	<b>ADJUSTMENT PROCEDURES</b> .....	6-1~5
6-1	PREPARATION BEFORE SERVICING .....	6-1
6-2	PLL ADJUSTMENT .....	6-2
6-3	RECEIVER ADJUSTMENT .....	6-2
6-4	TRANSMITTER ADJUSTMENT .....	6-4
<b>SECTION 7</b>	<b>BOARD LAYOUTS</b> .....	7-1~13
7-1	KEYBOARD AND PTT UNIT .....	7-1
7-2	LOGIC UNIT .....	7-2
7-3	INITIAL MATRICES .....	7-4
7-4	ADENCA UNIT .....	7-4
7-5	VR, UHF SW AND PRT UNITS .....	7-5
7-6	MAIN UNIT .....	7-6
7-7	AF, MIC AND REG UNITS .....	7-8
7-8	APC AND IO UNITS .....	7-9
7-9	DET AND UHF YGR UNITS .....	7-10
7-10	VHF RF, VHF COL, UHF RF AND UHF COL UNITS .....	7-11
7-11	VHF PLL, UHF PLL AND UHF VCO UNITS .....	7-12
7-12	LPF AND HPF UNITS .....	7-13
<b>SECTION 8</b>	<b>BLOCK DIAGRAM</b> .....	8-1
<b>SECTION 9</b>	<b>VOLTAGE DIAGRAM</b> .....	9-1~2

# SECTION 1 SPECIFICATIONS

## ■ GENERAL

- Frequency coverage

VERSION	TX/RX	FREQUENCY COVERAGE	
		VHF	UHF
IC-24AT (U.S.A.)	Transmit Receive	140~150 MHz 138~174 MHz	440~450 MHz 440~450 MHz
IC-24AT (Australia)	Transmit Receive	144~148 MHz 144~148 MHz	430~440 MHz 430~440 MHz
IC-24AT (Asia)	Transmit Receive	140~150 MHz 138~174 MHz	430~440 MHz 430~440 MHz
IC-24ET (Europe, U.K.)	Transmit Receive	144~146 MHz 144~146 MHz	430~440 MHz 430~440 MHz
IC-24ET (Italy)	Transmit Receive	140~150 MHz 138~174 MHz	430~440 MHz 430~440 MHz

Guaranteed frequency range : 144~148 MHz

- Mode
- Tuning step
- Memory channels
- Antenna impedance
- Power supply requirement
- Current drain (typical)  
(at 13.8 V DC)

- : F3 (FM)
- : 5, 10, 12.5, 15, 25 or 50 kHz
- : 40 plus 2 call channels
- : 50  $\Omega$  unbalanced
- : Icom battery packs or battery case (BP-81~BP-86, BP-90)
- : External power jack 6~16 V DC

TX/RX	CONDITION	CURRENT DRAIN	
		VHF	UHF
Transmit	High	1.3 A	1.6 A
	Low 1	0.5 A	0.7 A
Receive	AF max. power	150 mA	150 mA
	Power saved	16 mA	16 mA

- Usable temperature range
- Dimensions
- Weight

- : -10 °C ~ +60 °C (+14 °F ~ +140 °F)
- : 52 (W) X 156 (H) X 34.5 (D) mm
- : 2.0 (W) X 6.1 (H) X 1.4 (D) in (With the BP-86)
- : 52 (W) X 136.5 (H) X 34.5 (D) mm
- : 2.0 (W) X 5.4 (H) X 1.4 (D) in (With the BP-82)
- : (Projections not included)
- : 385 g (13.6 oz) (With the BP-86 and dry batteries)
- : 340 g (12.0 oz) (With the BP-82)

## ■ TRANSMITTER

- Output power (at 13.8 V DC)
- Modulation system
- Max. frequency deviation
- Spurious emissions
- Microphone impedance

- : High 5 W
- : Low 1 0.5 W
- : Low 2 1.5 W
- : Low 3 3.5 W
- : Variable reactance frequency modulation
- :  $\pm 5.0$  kHz
- : Less than -60 dB
- : 2 k $\Omega$

## ■ RECEIVER

- Receiver system
- Intermediate frequency
- Sensitivity
- Spurious response rejection
- Audio output power
- Audio output impedance

- : Double-conversion superheterodyne
- : 1st 30.875 MHz
- : 2nd 455 kHz
- : Less than 0.18  $\mu$  V for 12 dB SINAD
- : More than 60 dB
- : More than 200 mW at 10 % distortion with an 8  $\Omega$  load
- : 8  $\Omega$

All stated specifications are subject to change without notice or obligation.

## SECTION 2 INSIDE VIEWS

### ■ MAIN UNIT

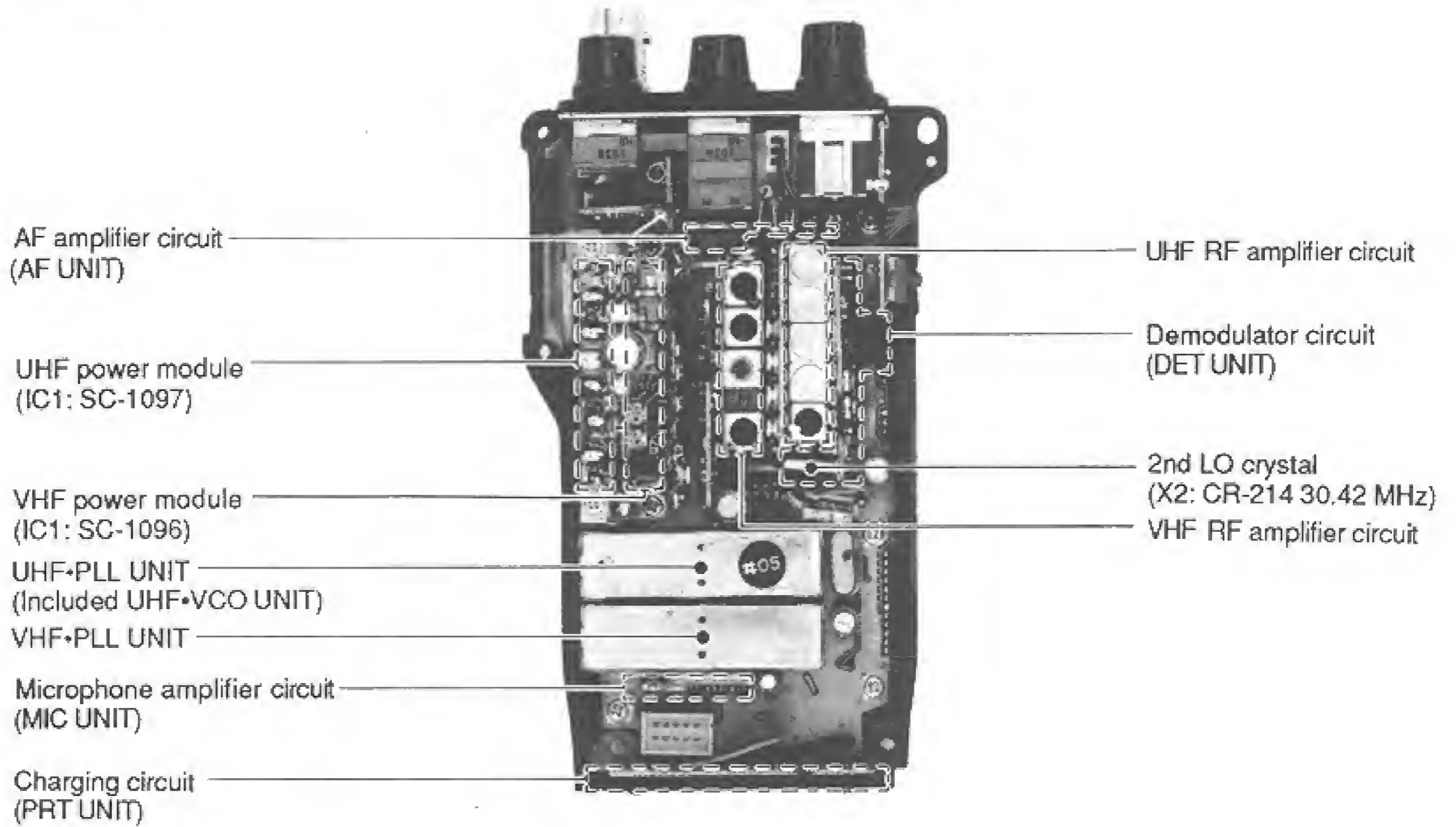

### ■ LOGIC UNIT

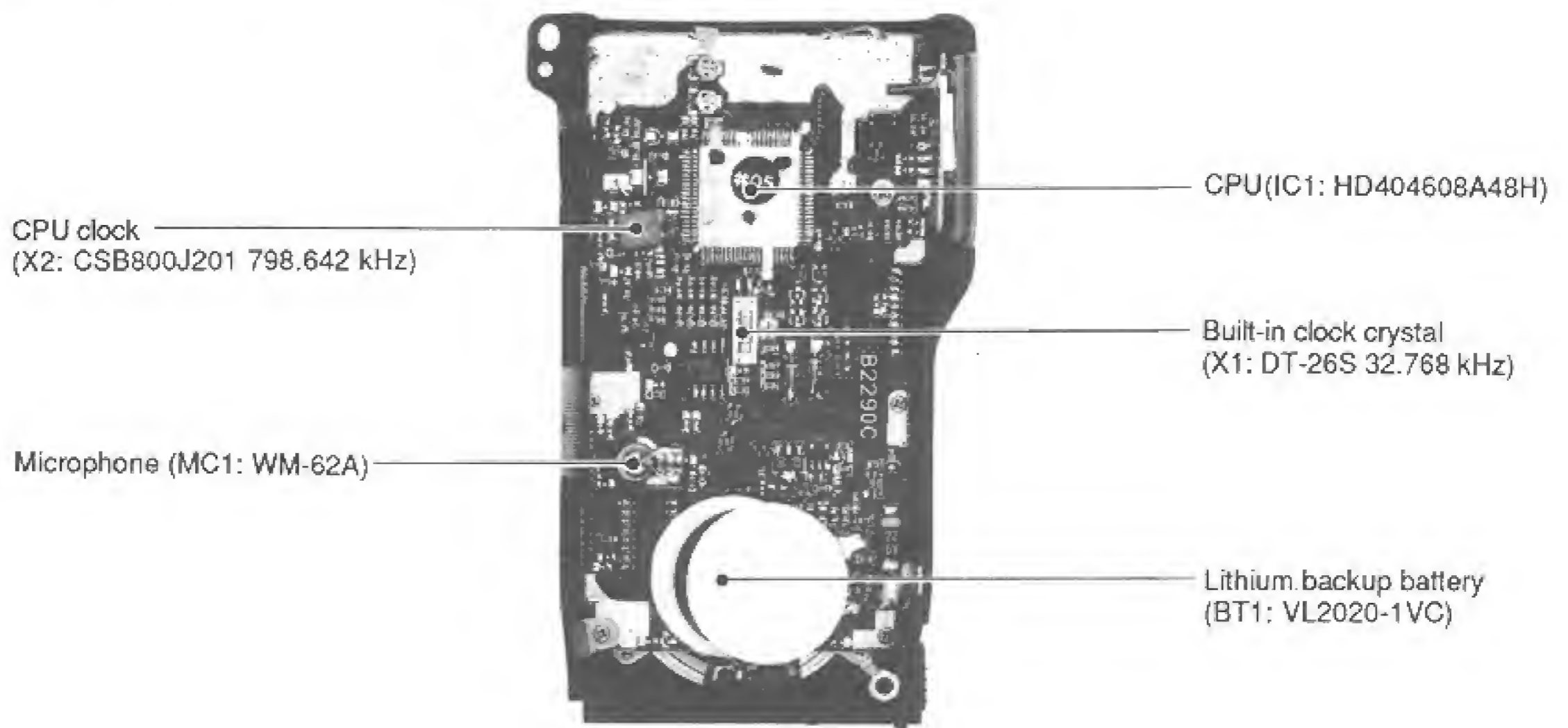

## SECTION 3 CIRCUIT DESCRIPTION

### 3-1 VHF RECEIVER CIRCUITS

#### 3-1-1 ANTENNA SWITCHING CIRCUIT (HPF UNIT)

The received signals that pass through the LPF UNIT are separated as VHF and UHF signals on the HPF UNIT and are applied to each RF amplifier circuit.

The HPF UNIT contains a high-pass filter, low-pass filter and an antenna switching circuit. The VHF signals pass through the low-pass filter (L3~L5, C6~C10) and the antenna switching circuit (C12~C14, L6, L7, D2). The VHF signals are then applied to the V•RF UNIT. The high-pass filter (C1~C5, L1, L2) is designed for UHF receiving and does not allow VHF signal passage.

#### 3-1-2 RF AND 1ST MIXER CIRCUITS (V•RF UNIT)

The RF and 1st mixer circuits are located on the V•RF UNIT where the signals are amplified at Q1 and Q2 and are then converted to a 1st IF signal at Q3. The frequency of the 1st IF signal is 30.875 MHz.

Q3 converts the RF signal using the V•PLL output signal coming from the "LLO" line.

The VHF RF circuit adopts a tuned bandpass filter circuit that tunes the filters to the center frequency of the receiving signal using varactor diodes (D2, D4, D5). A PLL lock voltage is used for the filter tuned signal.

#### 3-1-3 IF CIRCUIT (DET UNIT)

The 1st IF signal passed through the crystal filter (F11 on the MAIN UNIT) enters the DET UNIT. The DET UNIT converts the 1st IF signal to a 2nd IF signal and then detects AF signals. The unit also has a squelch circuit that is explained in Section 3-1-5.

The 1st IF signal amplified at Q3 is applied to the FM IF IC (IC1, pin20). IC1 contains mixer, oscillator, limiter amplifier, quadrature detector and meter detector circuits.

IC1 converts the entered signal from pin 20 to a 455 kHz 2nd IF signal using the oscillated signal and outputs the 2nd IF from pin 4 to pass through the crystal filter (F11). The 2nd IF signal re-enters IC1 (pin8) where it is converted to an AF signal at a quadrature detector (IC1, X1). The AF signals are output from IC1 (pin11) and are de-emphasized with  $-6$  dB/oct. at the integrating circuit (R8, C28, C29) and are then applied to the AF UNIT.

#### 3-1-4 AF CIRCUIT (AF UNIT)

The AF UNIT contains the AF drive amplifier (Q1, Q2), power amplifier (IC1), noise squelch switch (Q4~Q6) and tone squelch switch (Q3).

The AF signals from the DET UNIT are amplified at the AF drive amplifier and are passed through the [VOL] control on the VR UNIT and are then amplified at the power amplifier (IC1) to obtain the speaker driving level.

#### 3-1-5 SQUELCH CIRCUIT (DET AND AF UNITS)

In an FM receiver, noise signals are output from the speaker when no signal is received and are suppressed when a signal is received. The noise squelch circuit cuts off the noise signals using this phenomenon.

Noise components in AF signals (20 kHz and above) are amplified at the active filter (IC1, R10, R11, C14, C15 on the DET UNIT) and are rectified at D1 to convert to DC voltages. These voltages switch Q2. Thus, while receiving no signal, the "LOW" signal is output from the DET UNIT as the "BUSY" signal.

If the "BUSY" signal goes down, the "AFS" signal goes down. The "AFS" signal controls the power source (Q4~Q6) of the AF power amplifier (IC1). Thus, when the "BUSY" signal is at "LOW," the AF power amplifier does not operate.

When an optional tone squelch unit is installed, Q5 on the MAIN UNIT controls the "AFS" signal using the "TSQL" signal.

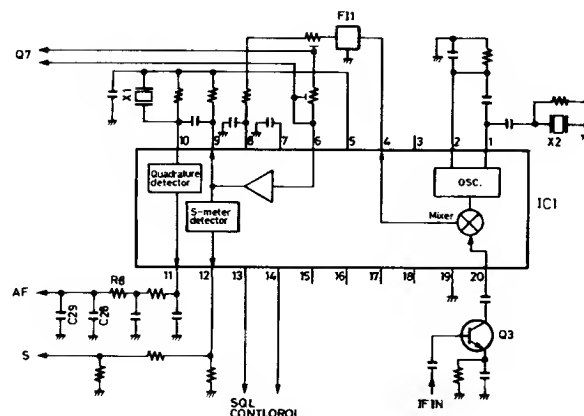

IF CIRCUIT

## 3-2 UHF RECEIVER CIRCUITS

### 3-2-1 ANTENNA SWITCHING CIRCUIT (U-SW UNIT)

The antenna switching circuit is mainly the same as the VHF band. Refer to Section 3-1-1 for details. The following parts are different from the VHF band:

The UHF signals pass through the high-pass filter (L1, L2, C1~C5 on the HPF UNIT) and the antenna switching circuit (L1, L2, C1~C3, D1 on the U-SW UNIT).

### 3-2-2 RF AND 1ST MIXER CIRCUITS (U-RF UNIT)

The RF and 1st mixer circuits are located on the U-RF UNIT where the signals are amplified at Q1 and Q2, and are then converted to a 1st IF signal at Q3. A frequency of the 1st IF signal is 30.875 MHz.

Q3 converts the RF signal using the U-PLL output coming from the "HLO" line.

The UHF RF circuit adopts a helical coil bandpass filter circuit (L1, L2) to suppress out-of-band signals.

### 3-2-3 IF, AF AND SQUELCH CIRCUITS

These are the same as the ones commonly used with the VHF receiver circuit. Refer to Section 3-1-3~3-1-5 for details.

## 3-3 VHF TRANSMITTER CIRCUITS

### 3-3-1 MIC AMP CIRCUIT (MIC UNIT)

The mic amplifier circuit amplifies audio signals with 6 dB/oct. pre-emphasis from the microphone to a level needed for the modulation circuit.

The MIC UNIT has a low level amplifier with pre-emphasis (IC3a) and a limiter amplifier (IC3b).

### 3-3-2 MODULATION CIRCUIT (V-PLL UNIT)

The modulation circuit modulates the VCO oscillating signal (RF signal) using the microphone audio signal.

The audio signal from the MIC UNIT (VMOD signal) changes the reactance of a varactor diode (D2) to modulate the oscillated signal at the TX VCO (Q5). The oscillated signal is buffer-amplified at Q6 and Q8, and is then applied to the drive amplifier circuit on the MAIN UNIT via the "VLO" line.

### 3-3-3 DRIVE AND POWER AMPLIFIER CIRCUITS (MAIN UNIT)

The drive amplifiers (Q8, Q9) and power amplifier (IC1) amplify the VCO oscillating signal to an output level. Collector currents of the drive amplifiers are controlled by the APC circuit (refer to Section 3-3-4 for details).

### 3-3-4 APC CIRCUIT (APC AND HPF UNITS)

The APC circuit selects high or low output power and protects the power amplifier from antenna mismatch impedance.

D1 on the LPF UNIT detects progressive wave and D3 on the HPF UNIT detects reflecting wave. When the antenna is matched at 50  $\Omega$ , the combined voltages of progressive and reflective detection (PDET voltages) are minimum values. The PDET signal is applied to the APC UNIT.

The APC UNIT contains the APC control circuit (Q2, Q4, Q6, Q7) and the UHF transmitter RF circuit (Q1, Q5). Q4 compares the PDET voltages and reference voltages. When the PDET voltages are higher than reference voltages, Q4 reduces collector currents of Q2 on the U-YGR UNIT. These currents are applied to the drive amplifiers (Q8, Q9 on the MAIN UNIT) via the "APD" line to reduce the RF output power.

HIGH or LOW output power is determined with the reference voltages of the APC circuit. IC1 (pins 6, 7) on the IO UNIT are used as the power selector ports and R4 and Q3 on the U-YGR UNIT are used as reference voltage adjustment.

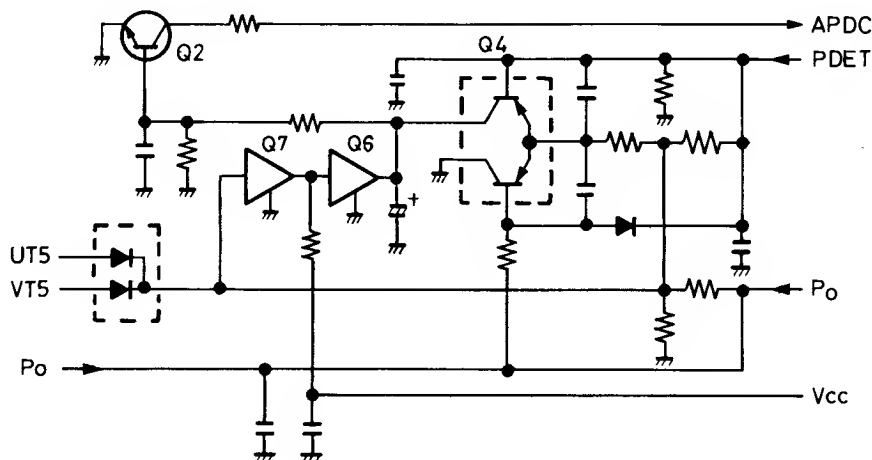

APC CIRCUIT

### 3-4 UHF TRANSMITTER CIRCUITS

#### 3-4-1 MIC AMP CIRCUIT (MIC UNIT)

This is the same as the one commonly used with the VHF transmitter circuit. See Section 3-3-1 for details.

#### 3-4-2 MODULATION CIRCUIT (U-PLL UNIT)

The audio signal from the MIC UNIT (UMOD) changes the reactance of a diode(D3)to modulate the oscillated signal at the VCO (Q11). The oscillated signal is amplified at the buffer amplifiers (Q2, Q3 on the U-PLL UNIT and Q7 on the MAIN UNIT) and is then applied to the drive amplifier circuit on the APC UNIT.

### 3-4-3 DRIVE AND POWER AMPLIFIER CIRCUITS (APC AND U-YGR UNITS)

The drive amplifiers (Q1 on the APC UNIT and Q1 on the U-YGR UNIT) and power amplifier (IC1 on the U-YGR UNIT) amplify the VCO oscillating signal to an output level. Collector currents of the drive amplifiers are controlled by the APC circuit (refer to Section 3-3-4 for details).

#### 3-4-4 APC CIRCUIT (APC AND HPF UNITS)

The APC circuit of the UHF band is mainly the same as the VHF band. Refer to Section 3-3-4 for details. The following parts are different from the VHF band:

Reflective detector : D4 on the U-YGR UNIT

Drive amplifiers : Q1 on the APC UNIT, Q1 on the U-YGR UNIT

Reference voltage adjustment: R3 and Q4 on the U-YGR UNIT

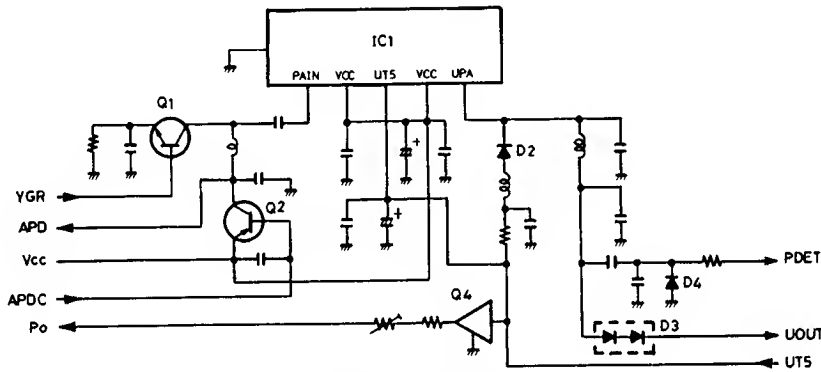

UHF AMPLIFIER CIRCUIT

### 3-5 PLL CIRCUITS

#### 3-5-1 GENERAL DESCRIPTION

A PLL circuit provides stable oscillation of the transmit frequency and the receive LO frequency. The PLL circuit compares phases of the divided VCO frequency and reference frequency. The PLL output frequency is controlled from a crystal oscillator and the divided ratio (N-data) of a programmed divider.

#### 3-5-2 VHF VCO CIRCUIT (V-PLL UNIT)

The VCO circuit oscillates the PLL output frequency controlling a varactor diode.

The V-PLL UNIT separately has receiver VCO (Q2) and transmitter VCO (Q5) for wide range oscillation and clear oscillation respectively. Q1 switches the VCOs.

#### 3-5-3 UHF VCO CIRCUIT (U-VCO UNIT)

Q11 oscillates both the receive LO and transmit frequency. When receiving, IC1 (pin10) is grounded and turns D2 ON to shift the VCO oscillating frequency.

#### 3-5-4 PHASE DETECTOR CIRCUIT (V-PLL AND U-PLL UNITS)

The phase detector circuit detects the off phase components of the VCO frequency using a stable reference frequency.

Both IC1s on the V-PLL and U-PLL UNITS are the 500 MHz one-chip PLL ICs that contain a two-modulus prescaler, swallow counter, programmable divider and phase detector. The VCO oscillated signal is amplified at Q7 (VHF band; on the V-PLL UNIT) or Q1 (UHF band; on the U-PLL UNIT) and is then applied to the PLL IC (pin1).

In IC1, the entered signal is divided at a prescaler and programmable divider sections. A reference frequency is also divided at a divider section. Both of the divided signals are compared at a phase-detector section to output their differential signal.



### 3-5-5 LOOP FILTER (V-PLL AND U-PLL UNITS)

A loop filter converts the phase-detected signal (pulse signal) to DC voltage (PLL lock voltage) to control the VCO oscillating signal. The PLL lock voltage changes the reactance of a varactor diode in the VCO circuit. The DC voltage of the VHF PLL is also used for the receiver tuning circuit.

The phase-detected signal output from the PLL IC (pin 13) passes through the charge pump control (IC2) and is applied to the following loop filter:

For VHF PLL : Lag-lead-type loop filter (R2, R3, C5, C6)  
For UHF PLL : Active loop filter (Q4, Q5, R10~R12, C15~C17)

The charge pump control (IC2) cuts off the line of IC1 and the loop filter while in the circuit off condition of the power saver function.

### 3-6 LOGIC CIRCUITS

#### 3-6-1 CPU PORT ALLOCATIONS (LOGIC UNIT)

PORT No.	PIN No.	TERMINAL NAME	DESCRIPTION
D0	77	BUSY LED	Becomes "HIGH" to light up DS4 in green when the squelch opens.
D1	78	IOSTB	Outputs a strobe signal to I/O expander ICs.
D2	79	TONEO	Outputs a 1750 kHz tone. Europe version only.
D3	80	LAMP LED	Becomes "HIGH" to light up LCD back light.
D4	1	PTT	Input port for the PTT switch. When receiving "LOW," "send data" are output via pin 17.
D5	2	SIN	Input port for the S-indicator. When receiving "LOW," S-indicator data are output via segment ports.
D6~D9	3~6	KEY S0~KEY S3	Output strobe signals for the initial and key matrices and S-indicator comparator circuit.
D10	7	UL	Input port for the unlock signal. When receiving "HIGH," "U" is displayed in the LCD and "send data" are not output via pin 17.
D11	8	NC	Not used.
D12	9	UP	Input port for "up" signal of the tuning control. When receiving "LOW," "frequency up" is counted.

PORT No.	PIN No.	TERMINAL NAME	DESCRIPTION
D13	10	DOWN	Input port for "down" signal of the tuning control. When receiving "LOW," "frequency down" is counted.
X1,X2	12,13	OSC	Input and output ports for CPU clock oscillator.
GND	14		Ground.
R00	15	CK	Outputs a clock signal.
R01	16	PLSV	Outputs a strobe signal for VHF PLL IC.
R02	17	DATA	Outputs serial data to PLL ICs and I/O expander ICs.
R03	18	PLSU	Outputs a strobe signal for UHF PLL IC.
R10~R13	19~22	KEY I0~KEY I3	Input ports for key matrices.
R20~R23	23~26	KEY R0~KEY R3	Input ports for initial matrices.
R30	27	BUSY	Input port for "BUSY" signal.
R31	28	OPT	Input port for optional unit installation. When receiving "LOW," the CPU detects that an optional unit has been installed.
R32	29	INT0	Input port for interrupt signal. When receiving "LOW," the CPU enters the standby mode.
SEG1~SEG32	31~62	LCD	Output the LCD driving signal.
COM1~COM4	63~64	LCD	Output the LCD driving signal.
V1	67	LCD BIAS	Input port for LCD bias voltage.
TONEC	70	DTMF ROW	Outputs the "ROW" signal of the DTMF.
TONER	71	DTMF COL	Outputs the "COL" signal of the DTMF.
VTref	72	DTMF Po	Input port for the power source of the DTMF generator.
Vcc	73		Input port for the power source of the CPU.
OSC1~OSC2	74~75		Input and output ports for the oscillator of the CPU clock.
RESET	76		Input port for the timing signal of power ON.

### 3-6-2 I/O EXPANDER IC PORT ALLOCATIONS

#### IC1 (IO UNIT)

PORT No.	PIN No.	TERMINAL NAME	DESCRIPTION
Q17	4	VCPC	Outputs power saver signal to cut the loop filter from the VHF PLL IC.
Q18	5	UCPC	Outputs power saver signal to cut the loop filter from the UHF PLL IC.
Q19, Q20	6, 7	P01, P02	Output RF output power selecting signal.
Q21	14	V5C	Becomes "LOW" when selecting the VHF band. This port is controlled with the power save function.
Q22	13	U5C	Becomes "LOW" when selecting the UHF band. This port is controlled with the power saver function.

#### IC2 (IO UNIT)

PORT No.	PIN No.	TERMINAL NAME	DESCRIPTION
Q11	6	UBAN	Becomes "LOW" when the UHF band is selected.
Q12	7	TR5	Becomes "HIGH" while transmitting and "LOW" while receiving.
Q14	13	VT5	Becomes "LOW" while transmitting in the VHF band.
Q15	12	UT5	Becomes "LOW" while transmitting in the UHF band.
Q16	11	T+5	Becomes "HIGH" while transmitting.

#### IC6 (LOGIC UNIT)

PORT No.	PIN No.	TERMINAL NAME	DESCRIPTION
Q3	6	AFON	Becomes "HIGH" to open the squelch for beep tone.
Q4	7	RMUT	Becomes "HIGH" to cut the AF signal while beep tone emits.
Q5	14	MICM	Becomes "HIGH" to mute the microphone input.
Q6	13	TX LED	Becomes "HIGH" to light up DS4 in red while transmitting.

### 3-6-3 S-INDICATOR COMPARATOR CIRCUIT (LOGIC UNIT)

The CPU indicates the 2nd IF signal level as the S-indicator (S-meter) to the LCD (DS1) when the SIN port (pin 2) is at "LOW."

The S-indicator signal coming from the DET UNIT is applied to the meter comparator (IC2, pin 3). Pin 2 of the meter comparator receives a counting signal from the CPU (pins 3-6). The counting signal is increased step by step.

The comparator (pin 1) is at "HIGH" when the counting signal is lower than the S-indicator signal and becomes "LOW" when the counting signal is higher than the S-indicator signal.

When the comparator (IC2, pin 1) becomes "LOW," the CPU detects that the signal strength level is the same as the counting signal level, and indicates the counting signal to the LCD.

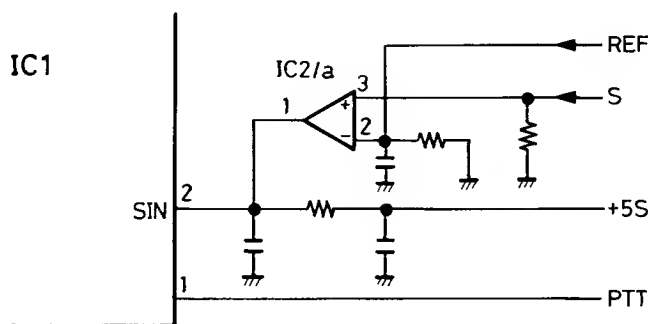

S-INDICATOR CIRCUIT

Downloaded by  
RadioAmateur.EU

### 3-6-4 CPU RESET CIRCUIT (LOGIC UNIT)

IC3 detects the 5 V line. When the 5 V line becomes higher than the threshold voltage of IC3, IC3 outputs "HIGH" as the interrupt signal.

While pushing the [FUNC] switch, power is turned ON that applies "HIGH" to the reset port of the CPU (pin 76). When the port receives "HIGH," the CPU is initialized.

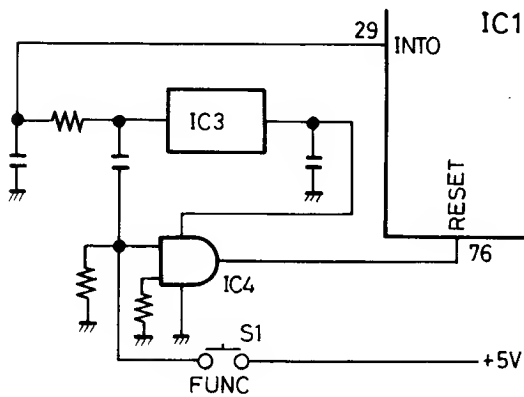

CPU RESET CIRCUIT

## 3-7 POWER SUPPLY CIRCUITS

### 3-7-1 BATTERY CHARGING CIRCUIT (PRT UNIT)

The transceiver has a constant-current regulated circuit for charging the connected battery pack.

Current to the battery pack is determined the base voltage of Q2. The base voltage is produced with R6, R8, D6 and feedback voltage from the battery pack.

### 3-7-2 VOLTAGE LINE (REG AND IO UNITS)

LINE	DESCRIPTION
Vcc	The attached battery pack or external DC power voltages are passed through the power switch.
+5M	5 V regulator (IC1 on REG UNIT) output.
+5	Current amplified voltage of +5M. Current amplifier: Q1 and Q2 on the REG UNIT.
+5S	Common 5 V with a power as saver function. Control signal : V5C and U5C. Current amplifier: Q3 and Q4 on the REG UNIT.
V+5S	5 V for the VHF band with a power saver function. Control signal : V5C. Current amplifier: Q6 on the REG UNIT.
U+5S	5 V for the UHF band with a power saver function. Control signal : U5C Current amplifier: Q5 on the REG UNIT.
V5C	5 V for the VHF band with a power saver function. Control signal : serial data from the CPU. Produced location: IC1, pin 14 on the IO UNIT.
U5C	5 V for the UHF band with a power saver function. Control signal : serial data from the CPU. Produced location: IC1, pin 13 on the IO UNIT.
R+5S	Receiver 5 V. Control signal : IC2, pins 4~7 on the IO UNIT. Current amplifier: Q5 and Q6 on the IO UNIT.
T+5	Transmitter 5 V. Control signal : IC2, pin 11 on the IO UNIT. Current amplifier: Q1 and Q2 on the IO UNIT.
UT5	UHF transmitter 5 V. Control signal : IC2, pin 12 on the IO UNIT. Current amplifier: Q3 on the IO UNIT.
VT5	VHF transmitter 5 V. Control signal : IC2, pin 14 on the IO UNIT. Current amplifier: Q4 on the IO UNIT.
HR5S	UHF band receiver 5 V with a power saver function. Control signal : IC2, pins 4~6 on the IO UNIT. Current amplifier: Q8 on the IO UNIT.
UB5S	Receiver 5 V for the UHF RF circuit with a power saver function. Control signal : IC2, pin 6 on the IO UNIT. Current amplifier: Q1 on the MAIN UNIT.

# SECTION 4 MECHANICAL PARTS AND DISASSEMBLY

## 4-1 FRONT PANEL

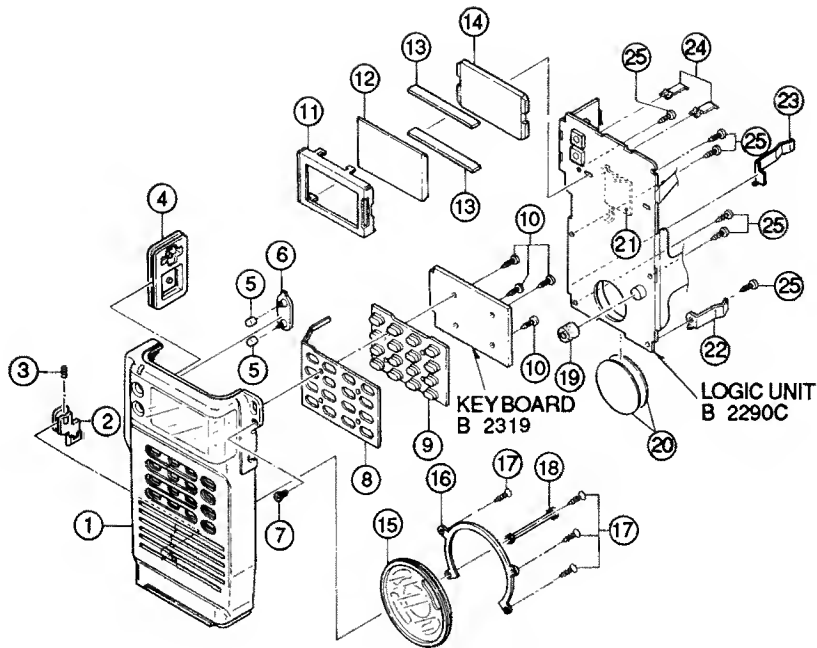

LABEL NO.	ORDER NO.	DESCRIPTION	QTY.
①	8210005421	758 Front panel (B) -1 IC-24ET (incl. Front plate)	1
	8210005431	758 Front panel (A) -1 IC-24AT (incl. Front plate)	1
②	8930014922	752 Release button -2	1
③	8930014820	Release spring (M)	1
④	8930016281	758 PTT switch rubber -1	1
⑤	8610005970	Knob K138	2
⑥	8930016291	758 Switch seal -1	1
⑦	8810000100	PH M2 X 4 ZK	1
⑧	8510006280	758 Key shield	1
⑨	8010009080	756 Keyboard	1
⑩	8810003850	PH B0 No.0-3 M1.4 X 2.5 NI	4
⑪	8930016320	758 LCD holder	1
⑫	5030000480	LCD LD-BU9394J	1

LABEL NO.	ORDER NO.	DESCRIPTION	QTY.
⑬	8930016260	LCD contact strip SRCN-758	2
⑭	8010009140	758 Reflector plate	1
⑮	2510000450	Speaker EAS-3P123D	1
⑯	8930014810	752 Speaker plate	1
⑰	8810005740	FH B0 No.0 M2 X 3	4
⑱	8930014830	Speaker ground spring	1
⑲	8930014940	752 MIC holder	1
⑳	8930011840	Battery insulating plate	2
㉑	8510006270	758 CPU shield plate	1
㉒	8930017240	758 L-C ground spring	1
㉓	8930017250	758 L-P ground spring	1
㉔	8930017870	758 Front ground spring	2
㉕	8810001700	PH B0 No.0-3 M1.4 X 3	6

### Screw abbreviations

BH : Button head  
 PH : Pan head  
 FH : Flat head  
 No.0: Precision-type screw  
 B0 : Self-tapping screw  
 BS : Brass  
 NI : Nickel  
 ZK : Black

## 4-2 REAR PANEL

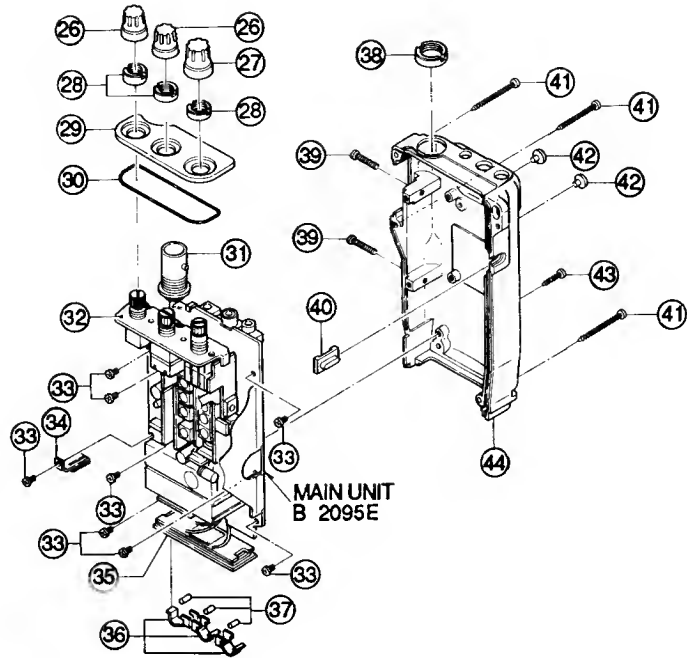

LABEL NO.	ORDER NO.	DESCRIPTION	QTY.
26	8610005780	Knob N146	2
27	8610005790	Knob N147	1
28	8830000550	VR nut (E)	3
29	8210005181	758 Top panel -1	1
30	8930016250	758 Top seal	1
31	6510011350	Antenna connector BNC-RM-F	1
32	8930016311	758 VR plate -1	1
33	8810005860	PH No.0 M2 X 3 NI	8
34	8930017260	758 Module ground spring	1
35	8930014971	752 Connector holder -1	1

LABEL NO.	ORDER NO.	DESCRIPTION	QTY.
36	8930014852	752 Battery terminal -2	3
37	8930016560	Terminal rubber	3
38	8830000620	BNC-R113 nut	1
39	8810005920	PH No.0 M2 X 10 ZK	2
40	8930014912	LAMP switch rubber -2	1
41	8810005720	PH B0 M2 X 20 ZK	3
42	8010007602	Bushing (A)-2	2
43	8810005710	PH B0 M2 X 6 ZK	1
44	8010009130	758 Rear panel	1

## 4-3 ACCESSORIES

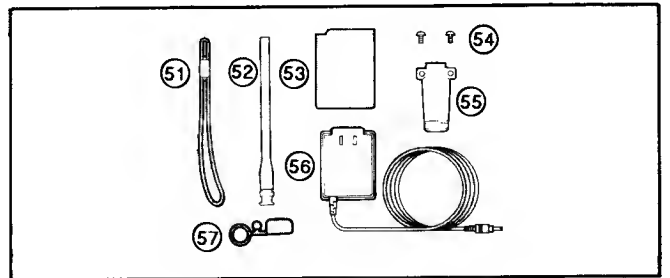

LABEL NO.	ORDER NO.	DESCRIPTION	QTY.
51	8010008970	Handstrap HK-002	1
52	Optional product	Antenna FA-1443BA	1
53	Optional product	Battery pack BP-82 (except SEA)	1
		Battery pack BP-90 (SEA)	1
54	8810005730	BH M3 X 3 ZK BS	2
55	8010008620	752 Belt clip	1

LABEL NO.	ORDER NO.	DESCRIPTION	QTY.
56	Optional product	Wall charger BC-73D (EUR, ITA)	1
		Wall charger BC-73E (UK)	1
		Wall charger BC-74A (USA)	1
		Wall charger BC-74V (AUS)	1
57	8930016301	758 Rainproof cap	1

\*No charger included for SEA MODEL.

# SECTION 5 PARTS LIST

## [MAIN UNIT]

REF. NO.	ORDER NO.	DESCRIPTION	
K1	1150000730	IC	SC1096
Q1	1590000650	Transistor	DTA144TU T107
Q2	1590000430	Transistor	DTC144EU T107
Q3	1510000510	Transistor	2SA1576 R T107
Q4	1590000680	Transistor	DTC114EU T107
Q5	1510000500	Transistor	2SA1162-GR (TE85R)
Q6	1530002280	Transistor	2SC4081 S T107
Q7	1530002560	Transistor	2SC4403-3-TR
Q8	1530002560	Transistor	2SC4403-3-TR
Q9	1530002340	Transistor	2SC2954-T2B
D1	1790000620	Diode	MA77 (TW)
D2	1790000620	Diode	MA77 (TW)
D3	1750000120	Diode	DWA010-TE
D4	1790000680	Diode	SB20-03P-TD
D5	1160000050	Diode	DAP202U T107
D6	1790000590	Diode	MA110 (TW)
D7	1160000060	Diode	DAN202U T107
D8	1790000620	Diode	MA77 (TW)
D9	1790000620	Diode	MA77 (TW)
D12	1750000130	Diode	DA204U T107
X1	6050006570	Crystal	CR-312
F11	2010001030	Filter	31L15BU (FL-123)
L1	6200000720	Coil	LQN 2A 10NM
L2	6200000720	Coil	LQN 2A 10NM
L3	6200000260	Coil	LQN 2A R10K
L4	6200000760	Coil	LQN 2A 56NM
L5	6200000120	Coil	LQN 2A 39NM
R1	7030003600	Resistor	ERJ3GEYJ 22k $\Omega$ (223V)
R2	7030003410	Resistor	ERJ3GEYJ 560 $\Omega$ (561V)
R3	7030003680	Resistor	ERJ3GEYJ 100k $\Omega$ (104V)
R4	7030003600	Resistor	ERJ3GEYJ 22k $\Omega$ (223V)
R5	7030003760	Resistor	ERJ3GEYJ 470k $\Omega$ (474V)
R6	7030003400	Resistor	ERJ3GEYJ 470 $\Omega$ (471V)
R7	7030003560	Resistor	ERJ3GEYJ 10k $\Omega$ (103V)
R8	7030003450	Resistor	ERJ3GEYJ 1.2k $\Omega$ (122V)
R9	7030003440	Resistor	ERJ3GEYJ 1k $\Omega$ (102V)
R10	7030003440	Resistor	ERJ3GEYJ 1k $\Omega$ (102V)
R11	7030003400	Resistor	ERJ3GEYJ 470 $\Omega$ (471V)
R13	7030003720	Resistor	ERJ3GEYJ 220k $\Omega$ (224V)
R14	7030003720	Resistor	ERJ3GEYJ 220k $\Omega$ (224V)
R15	7030003800	Resistor	ERJ3GEYJ 1M $\Omega$ (105V)
R16	7030003680	Resistor	ERJ3GEYJ 100k $\Omega$ (104V)
R17	7030003560	Resistor	ERJ3GEYJ 10k $\Omega$ (103V)
R19	7030003380	Resistor	ERJ3GEYJ 330 $\Omega$ (331V)
R20	7030003650	Resistor	ERJ3GEYJ 56k $\Omega$ (563V)
R21	7030003320	Resistor	ERJ3GEYJ 100 $\Omega$ (101V)
R22	7030003680	Resistor	ERJ3GEYJ 100k $\Omega$ (104V)
R23	7030003660	Resistor	ERJ3GEYJ 68k $\Omega$ (683V)
R24	7030003480	Resistor	ERJ3GEYJ 2.2k $\Omega$ (222V)
R25	7030003720	Resistor	ERJ3GEYJ 220k $\Omega$ (224V)
R26	7030003560	Resistor	ERJ3GEYJ 10k $\Omega$ (103V)
R27	7030003560	Resistor	ERJ3GEYJ 10k $\Omega$ (103V)
R28	7030003500	Resistor	ERJ3GEYJ 3.3k $\Omega$ (332V)
R30	7030003280	Resistor	ERJ3GEYJ 47 $\Omega$ (470V)
R31	7030003320	Resistor	ERJ3GEYJ 100 $\Omega$ (101V)
R32	7030003410	Resistor	ERJ3GEYJ 560 $\Omega$ (561V)
R33	7030003310	Resistor	ERJ3GEYJ 82 $\Omega$ (820V)
R34	7030003280	Resistor	ERJ3GEYJ 47 $\Omega$ (470V)
R35	7030003200	Resistor	ERJ3GEYJ 10 $\Omega$ (100V)
R36	7030003200	Resistor	ERJ3GEYJ 10 $\Omega$ (100V)
R37	7030003380	Resistor	ERJ3GEYJ 330 $\Omega$ (331V)
R40	7030003610	Resistor	ERJ3GEYJ 27k $\Omega$ (273V)
R41	7030003660	Resistor	ERJ3GEYJ 68k $\Omega$ (683V)
R42	7030003360	Resistor	ERJ3GEYJ 220 $\Omega$ (221V)

## [MAIN UNIT]

REF. NO.	ORDER NO.	DESCRIPTION			
C2	4030006520	Ceramic	C1608 SL 1H	010C-T-A	
C3	4030008570	Ceramic	C1608 SL 1H	75C-T-A	
C4	4030006530	Ceramic	C1608 SL 1H	020C-T-A	
C5	4030006850	Ceramic	C1608 JB 1H	471K-T-A	
C6	4030006860	Ceramic	C1608 JB 1H	102K-T-A	
C7	4030006610	Ceramic	C1608 SL 1H	100D-T-A	
C8	4030006850	Ceramic	C1608 JB 1H	471K-T-A	
C9	4030006850	Ceramic	C1608 JB 1H	471K-T-A	
C10	4030006850	Ceramic	C1608 JB 1H	471K-T-A	
C11	4030006860	Ceramic	C1608 JB 1H	102K-T-A	
C12	4030006860	Ceramic	C1608 JB 1H	102K-T-A	
C13	4030006860	Ceramic	C1608 JB 1H	102K-T-A	
C14	4550003030	Tantalum	TEMSVA 0J	475M-8L	
C15	4030006860	Ceramic	C1608 JB 1H	102K-T-A	
C16	4030006850	Ceramic	C1608 JB 1H	471K-T-A	
C17	4030006900	Ceramic	C1608 JB 1E	103K-T-A	
C18	4030006850	Ceramic	C1608 JB 1H	471K-T-A	
C19	4510003170	Electrolytic	16 FC2 47 $\mu$ F (D=5.0)		
C20	4550000460	Tantalum	TESVA 1C	105M1-8L	
C21	4030006850	Ceramic	C1608 JB 1H	471K-T-A	
C23	4510004030	Electrolytic	6.3 YK 20 $\mu$ F		
C24	4550000460	Tantalum	TESVA 1C	105M1-8L	
C26	4030006750	Ceramic	C1608 SL 1H	101J-T-A	
C27	4030006750	Ceramic	C1608 SL 1H	101J-T-A	
C28	4030006900	Ceramic	C1608 JB 1E	103K-T-A	
C29	4030005110	Ceramic	C2012 JB 1E	473K-T-A	
C30	4030006750	Ceramic	C1608 SL 1H	101J-T-A	
C31	4030006750	Ceramic	C1608 SL 1H	101J-T-A	
C32	4030006850	Ceramic	C1608 JB 1H	471K-T-A	
C33	4030006850	Ceramic	C1608 JB 1H	471K-T-A	
C34	4030006850	Ceramic	C1608 JB 1H	471K-T-A	
C35	4030006750	Ceramic	C1608 SL 1H	101J-T-A	
C36	4030006860	Ceramic	C1608 JB 1H	102K-T-A	
C37	4550002960	Tantalum	TESVA 1C	155M1-8L	
C38	4030006860	Ceramic	C1608 JB 1H	102K-T-A	
C39	4030006850	Ceramic	C1608 JB 1H	471K-T-A	
C40	4030006750	Ceramic	C1608 SL 1H	101J-T-A	
C41	4030006850	Ceramic	C1608 JB 1H	471K-T-A	
C42	4030006850	Ceramic	C1608 JB 1H	471K-T-A	
C45	4030006850	Ceramic	C1608 JB 1H	471K-T-A	
C46	4030006860	Ceramic	C1608 JB 1H	102K-T-A	
C47	4030006860	Ceramic	C1608 JB 1H	102K-T-A	
C48	4030004760	Ceramic	C2012 JF 1E	104Z-T-A	
C49	4030006860	Ceramic	C1608 JB 1H	102K-T-A	
C50	4030006570	Ceramic	C1608 SL 1H	060D-T-A	
C51	4030007130	Ceramic	C1608 CH 1H	101J-T-A	
C52	4030007090	Ceramic	C1608 CH 1H	470J-T-A	
C53	4030008560	Ceramic	C1608 CH 1H	300J-T-A	
C54	4610000920	Trimmer	ECRGA010A30		
C55	4030006860	Ceramic	C1608 JB 1H	102K-T-A	
C58	4030006850	Ceramic	C1608 JB 1H	471K-T-A	
C59	4030006860	Ceramic	C1608 JB 1H	102K-T-A	
C60	4030006610	Ceramic	C1608 SL 1H	100D-T-A	
C61	4030006900	Ceramic	C1608 JB 1E	103K-T-A	
C62	4030006860	Ceramic	C1608 JB 1H	102K-T-A	
C63	4030006860	Ceramic	C1608 JB 1H	102K-T-A	
C64	4030006900	Ceramic	C1608 JB 1E	103K-T-A	
C65	4030006660	Ceramic	C1608 SL 1H	220J-T-A	
C66	4030006860	Ceramic	C1608 JB 1H	102K-T-A	
C67	4030006860	Ceramic	C1608 JB 1H	102K-T-A	
C68	4030006860	Ceramic	C1608 JB 1H	102K-T-A	
C69	4550000460	Tantalum	TESVA 1C	105M1-8L	
C72	4030005090	Ceramic	C2012 JB 1H	223K-T-A	
J1	6450001060	Connector	HSJ1493-01-010		
J2	6450000130	Connector	HSJ1102-01-540		
J3	6450000870	Connector	HEC2711-01-020		
EP1	0910021835	P.C. Board	B 2095E (MAIN)		
EP3	0910023521	P.C. Board	B 2100A		

[AF UNIT]

REF. NO.	ORDER NO.	DESCRIPTION	
K1	1110001810	K	TA7368F (TP1)
Q1	1530002060	Transistor	2SC4081 R T107
Q2	1530002060	Transistor	2SC4081 R T107
Q3	1590000520	FET	2SJ106-GR (TE85R)
Q4	1520000270	Transistor	2SB1182 Q T201
Q5	1530002060	Transistor	2SC4081 R T107
Q6	1530002060	Transistor	2SC4081 R T107
D1	1160000050	Diode	DAP202U T107
R1	7030003580	Resistor	ERJ3GEYJ 15k Ω (153V)
R2	7030003700	Resistor	ERJ3GEYJ 150k Ω (154V)
R3	7030003760	Resistor	ERJ3GEYJ 470k Ω (474V)
R4	7030003560	Resistor	ERJ3GEYJ 10k Ω (103V)
R5	7030003480	Resistor	ERJ3GEYJ 2.2k Ω (222V)
R6	7030003630	Resistor	ERJ3GEYJ 39k Ω (393V)
R7	7030003630	Resistor	ERJ3GEYJ 39k Ω (393V)
R8	7030003480	Resistor	ERJ3GEYJ 2.2k Ω (222V)
R9	7030003800	Resistor	ERJ3GEYJ 1M Ω (105V)
R10	7030003320	Resistor	ERJ3GEYJ 100 Ω (101V)
R13	7030003200	Resistor	ERJ3GEYJ 10 Ω (100V)
R14	7030003420	Resistor	ERJ3GEYJ 680 Ω (681V)
R15	7030003420	Resistor	ERJ3GEYJ 680 Ω (681V)
R16	7030003600	Resistor	ERJ3GEYJ 22k Ω (223V)
R18	7030003760	Resistor	ERJ3GEYJ 470k Ω (474V)
R19	7030003560	Resistor	ERJ3GEYJ 10k Ω (103V)
R20	7030003340	Resistor	ERJ3GEYJ 150 Ω (151V)
R21	7030003520	Resistor	ERJ3GEYJ 4.7k Ω (472V)
C1	4030006900	Ceramic	C1608 JB 1E 103K-T-A
C2	4030006900	Ceramic	C1608 JB 1E 103K-T-A
C3	4030006870	Ceramic	C1608 JB 1H 222K-T-A
C4	4030006860	Ceramic	C1608 JB 1H 102K-T-A
C5	4030004760	Ceramic	C2012 JF 1E 104Z-T-A
C6	4030005110	Ceramic	C2012 JB 1E 473K-T-A
C7	4030006860	Ceramic	C1608 JB 1H 102K-T-A
C10	4510003770	Electrolytic	10 RC2 33 μF (D=4.0)
C11	4030005110	Ceramic	C2012 JB 1E 473K-T-A
C12	4030006850	Ceramic	C1608 JB 1H 471K-T-A
C13	4510003180	Electrolytic	6.3 RC2 100 μF (D=5.0)
C14	4550003290	Tantalum	TESVA 0G 475M1-8L
C15	4030006860	Ceramic	C1608 JB 1H 102K-T-A
C16	4030006860	Ceramic	C1608 JB 1H 102K-T-A
C17	4030005110	Ceramic	C2012 JB 1E 473K-T-A
C19	4030006710	Ceramic	C1608 SL 1H 470J-T-A
C20	4550002950	Tantalum	TESVA 0J 35M1-8L
C21	4030004760	Ceramic	C2012 JF 1E 104Z-T-A
EP1	0910021633	P.C. Board	B 2092C (AF)
EP2	6910003110	Lead Frame	HFB2.0-0.7-8 (N)

[APC UNIT]

REF. NO.	ORDER NO.	DESCRIPTION	
Q1	1530002560	Transistor	2SC4403-3-TR
Q2	1530002280	Transistor	2SC4081 S T107
Q4	1590000620	Transistor	FMS1 T148
Q5	1590000650	Transistor	DTA144TU T107
Q6	1590000660	Transistor	DTC144TU T107
Q7	1590001030	Transistor	DTC144WU T107
D1	1790000450	Diode	MA862 (TX)
D2	1750000130	Diode	DA204U T107
D3	1790000590	Diode	MA110 (TW)
D4	1160000060	Diode	DAN202U T107
L1	6200000090	Coil	LQN 2A 18NM

[APC UNIT]

REF. NO.	ORDER NO.	DESCRIPTION			
R1	7030003560	Resistor	ERJ3GEYJ	10k Ω	(103V)
R2	7030003500	Resistor	ERJ3GEYJ	3.3k Ω	(332V)
R3	7030003410	Resistor	ERJ3GEYJ	560 Ω	(561V)
R4	7030003410	Resistor	ERJ3GEYJ	560 Ω	(561V)
R5	7030003280	Resistor	ERJ3GEYJ	47 Ω	(470V)
R6	7030003200	Resistor	ERJ3GEYJ	10 Ω	(100V)
R7	7030003280	Resistor	ERJ3GEYJ	47 Ω	(470V)
R8	7030003530	Resistor	ERJ3GEYJ	5.6k Ω	(562V)
R10	7030003770	Resistor	ERJ3GEYJ	560k Ω	(564V)
R11	7030003660	Resistor	ERJ3GEYJ	68k Ω	(683V)
R13	7030003600	Resistor	ERJ3GEYJ	22k Ω	(223V)
R14	7030003670	Resistor	ERJ3GEYJ	82k Ω	(823V)
R15	7030003610	Resistor	ERJ3GEYJ	27k Ω	(273V)
R16	7030003440	Resistor	ERJ3GEYJ	1k Ω	(102V)
R17	7030003730	Resistor	ERJ3GEYJ	270k Ω	(274V)
R18	7030003520	Resistor	ERJ3GEYJ	4.7k Ω	(472V)
R19	7030003680	Resistor	ERJ3GEYJ	100k Ω	(104V)
R20	7030003520	Resistor	ERJ3GEYJ	4.7k Ω	(472V)
R21	7030003520	Resistor	ERJ3GEYJ	4.7k Ω	(472V)
R22	7030003640	Resistor	ERJ3GEYJ	47k Ω	(473V)
R23	7030003520	Resistor	ERJ3GEYJ	4.7k Ω	(472V)
C1	4030006850	Ceramic	C1608 JB	1H	471K-T-A
C2	4030006850	Ceramic	C1608 JB	1H	471K-T-A
C3	4030006850	Ceramic	C1608 JB	1H	471K-T-A
C4	4030006850	Ceramic	C1608 JB	1H	471K-T-A
C5	4030006850	Ceramic	C1608 JB	1H	471K-T-A
C6	4030006850	Ceramic	C1608 JB	1H	471K-T-A
C7	4030006560	Ceramic	C1608 SL	1H	050C-T-A
C8	4030006850	Ceramic	C1608 JB	1H	471K-T-A
C9	4030006850	Ceramic	C1608 JB	1H	471K-T-A
C10	4030006850	Ceramic	C1608 JB	1H	471K-T-A
C11	4550002970	Tantalum	TEMSVA	0G	685M-8L
C12	4030006850	Ceramic	C1608 JB	1H	471K-T-A
C13	4030006850	Ceramic	C1608 JB	1H	471K-T-A
C14	4030006850	Ceramic	C1608 JB	1H	471K-T-A
C15	4030006850	Ceramic	C1608 JB	1H	471K-T-A
C16	4030006850	Ceramic	C1608 JB	1H	471K-T-A
C17	4030006850	Ceramic	C1608 JB	1H	471K-T-A
C18	4550003040	Tantalum	TEMSVB2	0J	106M-8L
C19	4030006850	Ceramic	C1608 JB	1H	471K-T-A
C20	4030006850	Ceramic	C1608 JB	1H	471K-T-A
C21	4030006850	Ceramic	C1608 JB	1H	471K-T-A
C22	4030006850	Ceramic	C1608 JB	1H	471K-T-A
EP1	0910023204	P.C. Board	B 2252D (APC)		
EP2	6910003110	Lead Frame	HFB2.0-0.7-8 (N)		

[MIC UNIT]

REF. NO.	ORDER NO.	DESCRIPTION			
K1	1130004200	K	TC4S66F (TE85R)		
K2	1130004200	K	TC4S66F (TE85R)		
K3	1110001540	K	M5218FP-71A		
Q1	1590000410	Transistor	RN2404 (TE85R)		
R1	7030003440	Resistor	ERJ3GEYJ	1k Ω	(102V)
R2	7030003710	Resistor	ERJ3GEYJ	180k Ω	(184V)
R3	7030003670	Resistor	ERJ3GEYJ	82k Ω	(823V)
R4	7030003740	Resistor	ERJ3GEYJ	330k Ω	(334V)
R5	7030003680	Resistor	ERJ3GEYJ	100k Ω	(104V)
R6	7030003640	Resistor	ERJ3GEYJ	47k Ω	(473V)
R7	7030003880	Resistor	ERJ3GEYJ	240k Ω	(244V)
R8	7030003330	Resistor	ERJ3GEYJ	120 Ω	(121V)
				(AUS, SEA, EUR, UK, ITA)	
	7030003370	Resistor	ERJ3GEYJ	270 Ω	(271V)
				(USA)	
R9	7030003710	Resistor	ERJ3GEYJ	180k Ω	(184V)
R10	7030003680	Resistor	ERJ3GEYJ	100k Ω	(104V)
R11	7030003720	Resistor	ERJ3GEYJ	220k Ω	(224V)
R12	7030003630	Resistor	ERJ3GEYJ	39k Ω	(393V)

[MIC UNIT]

REF. NO.	ORDER NO.	DESCRIPTION	
R13	7030003630	Resistor	ERJ3GEYJ 39k Ω (393V)
R14	7310002600	Trimmer	RV-110 (RH03 A3AS4X0AA) 473
R15	7310002600	Trimmer	RV-110 (RH03 A4AS4X0AA) 473
R17	7030003620	Resistor	ERJ3GEYJ 33k Ω (333V)
R18	7030003560	Resistor	ERJ3GEYJ 10k Ω (103V)
R19	7030003540	Resistor	ERJ3GEYJ 6.8k Ω (682V)
R20	7510000180	Thermistor	DTN-T203S223LS(T)
R21	7030003570	Resistor	ERJ3GEYJ 12k Ω (123V)
R22	7030003560	Resistor	ERJ3GEYJ 10k Ω (103V)
R23	7030003540	Resistor	ERJ3GEYJ 6.8k Ω (682V)
R24	7510000180	Thermistor	DTN-T203S223LS(T)
R25	7030003570	Resistor	ERJ3GEYJ 12k Ω (123V)
C1	4510002600	Electrolytic	16 RC3 4.7 μ F (3X5)
C2	4030006860	Ceramic	C1608 JB 1H 102K-T-A
C4	4030006880	Ceramic	C1608 JB 1H 472K-T-A
C5	4030006850	Ceramic	C1608 JB 1H 471K-T-A
C6	4030006850	Ceramic	C1608 JB 1H 471K-T-A
C7	4550000550	Tantalum	TESVA 1V 224M1-8L (AUS, SEA, EUR, UK, ITA)
	4550000530	Tantalum	TESVA 1V 104M1-8L (USA)
C8	4030006750	Ceramic	C1608 SL 1H 101J-T-A
C9	4030006900	Ceramic	C1608 JB 1E 103K-T-A
C10	4030008470	Ceramic	C1608 JB 1H 272K-T-A
C11	4030006760	Ceramic	C1608 SL 1H 121J-T-A
C12	4030006850	Ceramic	C1608 JB 1H 471K-T-A
C14	4030006850	Ceramic	C1608 JB 1H 471K-T-A
C15	4030006710	Ceramic	C1608 SL 1H 470J-T-A
C16	4030005110	Ceramic	C2012 JB 1E 473K-T-A
C17	4030005110	Ceramic	C2012 JB 1E 473K-T-A
C18	4030006900	Ceramic	C1608 JB 1E 103K-T-A
C19	4030006900	Ceramic	C1608 JB 1E 103K-T-A
EP1	6910003110	Lead Frame	HFB2.0-0.7-8 (N)
EP2	0910023022	P.C. Board	B 2042B (MIC)

[REG UNIT]

REF. NO.	ORDER NO.	DESCRIPTION	
C5	4030006850	Ceramic	C1608 JB 1H 471K-T-A
C6	4510003190	Electrolytic	6.3 RC2 47 μ F (D=4.0)
C7	4030006850	Ceramic	C1608 JB 1H 471K-T-A
C8	4030006850	Ceramic	C1608 JB 1H 471K-T-A
C9	4030006850	Ceramic	C1608 JB 1H 471K-T-A
C10	4030006850	Ceramic	C1608 JB 1H 471K-T-A
C11	4030006850	Ceramic	C1608 JB 1H 471K-T-A
C12	4030006850	Ceramic	C1608 JB 1H 471K-T-A
C13	4030006850	Ceramic	C1608 JB 1H 471K-T-A
C14	4030006850	Ceramic	C1608 JB 1H 471K-T-A
EP1	0910021743	P.C. Board	B 2040C (REG)
EP2	6910003110	Lead Frame	HFB2.0-0.7-8 (N)

[IO UNIT]

REF. NO.	ORDER NO.	DESCRIPTION	
K1	1130000830	IC	μ PD4094BG-T1
K2	1130000830	IC	μ PD4094BG-T1
K3	1130003760	IC	TC4S81F (TE85R)
K4	1130004500	IC	TC4S11F (TE85R)
Q1	1530002280	Transistor	2SC4081 S T107
Q2	1520000270	Transistor	2SB1182 Q T201
Q3	1510000580	Transistor	2SA1362-GR (TE85R)
Q4	1510000580	Transistor	2SA1362-GR (TE85R)
Q5	1530002280	Transistor	2SC4081 S T107
Q6	1520000200	Transistor	2SB798-DK-T2
Q7	1590000740	Transistor	FMA4 T148
Q8	1590000720	Transistor	DTA144EU T107
D1	1160000050	Diode	DAP202U T107
D2	1160000050	Diode	DAP202U T107
D3	1750000180	Diode	1SS308 (TE85R)
D4	1750000180	Diode	1SS308 (TE85R)
R1	7030003680	Resistor	ERJ3GEYJ 100k Ω (104V)
R2	7030003720	Resistor	ERJ3GEYJ 220k Ω (224V)
R3	7030003510	Resistor	ERJ3GEYJ 3.9k Ω (392V)
R4	7030003540	Resistor	ERJ3GEYJ 6.8k Ω (682V)
R5	7030003540	Resistor	ERJ3GEYJ 6.8k Ω (682V)
R6	7030003560	Resistor	ERJ3GEYJ 10k Ω (103V)
R7	7030003680	Resistor	ERJ3GEYJ 100k Ω (104V)
C1	4030006850	Ceramic	C1608 JB 1H 471K-T-A
C2	4030006850	Ceramic	C1608 JB 1H 471K-T-A
C3	4030006710	Ceramic	C1608 SL 1H 470J-T-A
C4	4030006850	Ceramic	C1608 JB 1H 471K-T-A
C5	4030006850	Ceramic	C1608 JB 1H 471K-T-A
C6	4030006850	Ceramic	C1608 JB 1H 471K-T-A
C7	4030006850	Ceramic	C1608 JB 1H 471K-T-A
C8	4030006850	Ceramic	C1608 JB 1H 471K-T-A
C9	4030006850	Ceramic	C1608 JB 1H 471K-T-A
C10	4030006850	Ceramic	C1608 JB 1H 471K-T-A
C11	4030006850	Ceramic	C1608 JB 1H 471K-T-A
C12	4030006850	Ceramic	C1608 JB 1H 471K-T-A
C13	4030006850	Ceramic	C1608 JB 1H 471K-T-A
C14	4030006850	Ceramic	C1608 JB 1H 471K-T-A
C15	4030006850	Ceramic	C1608 JB 1H 471K-T-A
C16	4030006850	Ceramic	C1608 JB 1H 471K-T-A
C17	4030006850	Ceramic	C1608 JB 1H 471K-T-A
C18	4030006850	Ceramic	C1608 JB 1H 471K-T-A
EP1	0910021874	P.C. Board	B 2041D (IO)

[REG UNIT]

REF. NO.	ORDER NO.	DESCRIPTION	
IC1	1180000530	IC	S-81250HG-RD-T1
IC2	1130004500	IC	TC4S11F (TE85R)
Q1	1530002280	Transistor	2SC4081 S T107
Q2	1520000200	Transistor	2SB798-DK-T2
Q3	1530002280	Transistor	2SC4081 S T107
Q4	1520000200	Transistor	2SB798-DK-T2
Q5	1510000670	Transistor	2SA1588-GR (TE85R)
Q6	1510000670	Transistor	2SA1588-GR (TE85R)
D1	1790000590	Diode	MA110 (TW)
D2	1790000590	Diode	MA110 (TW)
R1	7030003420	Resistor	ERJ3GEYJ 680 Ω (681V)
R2	7030003520	Resistor	ERJ3GEYJ 4.7k Ω (472V)
R3	7030003560	Resistor	ERJ3GEYJ 10k Ω (103V)
R4	7030003540	Resistor	ERJ3GEYJ 6.8k Ω (682V)
R5	7030003560	Resistor	ERJ3GEYJ 10k Ω (103V)
R6	7030003560	Resistor	ERJ3GEYJ 10k Ω (103V)
C1	4030006850	Ceramic	C1608 JB 1H 471K-T-A
C2	4510002280	Electrolytic	16 RC3 22 μ F
C3	4030006850	Ceramic	C1608 JB 1H 471K-T-A
C4	4510003190	Electrolytic	6.3 RC2 47 μ F (D=4.0)



[DET UNIT]

REF. NO.	ORDER NO.	DESCRIPTION	
IC1	1120001650	IC	TK10487MT1
Q1	1590000430	Transistor	DTC144EU T107
Q2	1530002280	Transistor	2SC4081 S T107
Q3	1530002020	Transistor	2SC3770-3-TA
Q4	1530002280	Transistor	2SC4081 S T107
Q5	1590000830	Transistor	FMG2 T149
Q6	1530002280	Transistor	2SC4081 S T107
Q7	1560000530	FET	2SK890-GR (TE85R)
Q8	1530002280	Transistor	2SC4081 S T107
D1	1790000490	Diode	HSM88AS-TR
X1	6070000060	Discriminator	CDBM455C7
X2	6050000510	Crystal	CR-214
FI1	2020000550	Ceramic Filter	CFUM455E
R1	7030003480	Resistor	ERJ3GEYJ 2.2k Ω (222V)
R2	7030003440	Resistor	ERJ3GEYJ 1k Ω (102V)
R3	7030003400	Resistor	ERJ3GEYJ 470 Ω (471V)
R4	7310002590	Trimmer	RV-109 (RH03 A3AJX0BA) 222
R5	7030003520	Resistor	ERJ3GEYJ 4.7k Ω (472V)
R6	7030003460	Resistor	ERJ3GEYJ 1.5k Ω (152V)
R7	7030003400	Resistor	ERJ3GEYJ 470 Ω (471V)
R8	7030003560	Resistor	ERJ3GEYJ 10k Ω (103V)
R9	7030003480	Resistor	ERJ3GEYJ 2.2k Ω (222V)
R10	7030003730	Resistor	ERJ3GEYJ 270k Ω (274V)
R11	7030003520	Resistor	ERJ3GEYJ 4.7k Ω (472V)
R12	7030003680	Resistor	ERJ3GEYJ 100k Ω (104V)
R13	7030003800	Resistor	ERJ3GEYJ 1M Ω (105V)
R14	7030003630	Resistor	ERJ3GEYJ 39k Ω (393V)
R15	7030003430	Resistor	ERJ3GEYJ 820 Ω (821V)
R16	7030003400	Resistor	ERJ3GEYJ 470 Ω (471V)
R17	7030003400	Resistor	ERJ3GEYJ 470 Ω (471V)
R18	7030003640	Resistor	ERJ3GEYJ 47k Ω (473V)
R19	7030003840	Resistor	ERJ3GEYJ 2.2M Ω (225V)
R20	7030003490	Resistor	ERJ3GEYJ 2.7k Ω (272V)
R21	7030003520	Resistor	ERJ3GEYJ 4.7k Ω (472V)
R22	7030003680	Resistor	ERJ3GRYJ 100k Ω (104V)
R23	7030003760	Resistor	ERJ3GEYJ 470k Ω (474V)
R24	7030003630	Resistor	ERJ3GEYJ 39k Ω (393V)
R25	7030003550	Resistor	ERJ3GEYJ 8.2k Ω (822V)
R26	7310002760	Trimmer	RV-152 (RH03 A3AJ4X0HA) 223
R27	7030003730	Resistor	ERJ3GEYJ 270k Ω (274V)
R28	7030003720	Resistor	ERJ3GEYJ 220k Ω (224V)
R29	7030003720	Resistor	ERJ3GEYJ 220k Ω (224V)
R30	7030003720	Resistor	ERJ3GEYJ 220k Ω (224V)
R31	7030003720	Resistor	ERJ3GEYJ 220k Ω (224V)
C1	4030004760	Ceramic	C2012 JF 1E 104Z-T-A
C2	4030006740	Ceramic	C1608 SL 1H 820J-T-A
C3	4030004760	Ceramic	C2012 JF 1E 104Z-T-A
C4	4030004760	Ceramic	C2012 JF 1E 104Z-T-A
C5	4030004760	Ceramic	C2012 JF 1E 104Z-T-A
C6	4030006640	Ceramic	C1608 SL 1H 180J-T-A
C7	4030006720	Ceramic	C1608 SL 1H 560J-T-A
C8	4030006860	Ceramic	C1608 JB 1H 102K-T-A
C9	4030006860	Ceramic	C1608 JB 1H 102K-T-A
C10	4030006860	Ceramic	C1608 JB 1H 102K-T-A
C11	4030006850	Ceramic	C1608 JB 1H 471K-T-A
C12	4030006710	Ceramic	C1608 SL 1H 470J-T-A
C13	4030006860	Ceramic	C1608 JB 1H 102K-T-A
C14	4030006860	Ceramic	C1608 JB 1H 102K-T-A
C15	4030006690	Ceramic	C1608 SL 1H 330J-T-A
C16	4030006860	Ceramic	C1608 JB 1H 102K-T-A
C17	4030004760	Ceramic	C2012 JF 1E 104Z-T-A
C18	4030006850	Ceramic	C1608 JB 1H 471K-T-A
C19	4030006850	Ceramic	C1608 JB 1H 471K-T-A
C20	4550002890	Tantalum	TESVA 1A 225M1-8L
C21	4030006890	Ceramic	C1608 JF 1H 103Z-T-A
C22	4030006890	Ceramic	C1608 JF 1H 103Z-T-A
C23	4030006890	Ceramic	C1608 JF 1H 103Z-T-A

[DET UNIT]

REF. NO.	ORDER NO.	DESCRIPTION	
C24	4030006900	Ceramic	C1608 JB 1E 103K-T-A
C25	4030006860	Ceramic	C1608 JB 1H 102K-T-A
C26	4030005110	Ceramic	C2012 JB 1E 473K-T-A
C27	4550002890	Tantalum	TESVA 1A 225M1-8L
C28	4030005110	Ceramic	C2012 JB 1E 473K-T-A
C29	4030005110	Ceramic	C2012 JB 1E 473K-T-A
C30	4030006890	Ceramic	C1608 JF 1H 103Z-T-A
C31	4030006860	Ceramic	C1608 JB 1H 102K-T-A
EP1	0910023013	P.C. Board	B 2039C (DET)
EP2	6910003110	Lead Frame	HFB2.0-0.7-8 (N)

[UHF RF UNIT]

REF. NO.	ORDER NO.	DESCRIPTION	
Q1	1530002640	Transistor	2SC3583 R34-T2B
Q2	1530002640	Transistor	2SC3583 R34-T2B
Q3	1530002560	Transistor	2SC4403-3-TR
D1	1790000620	Diode	MA77 (TW)
D3	1790000620	Diode	MA77 (TW)
L3	620000720	Coil	LQN 2A 10NM
R1	7030003560	Resistor	ERJ3GEYJ 10k Ω (103V)
R2	7030003500	Resistor	ERJ3GEYJ 3.3k Ω (332V)
R3	7030003620	Resistor	ERJ3GEYJ 33k Ω (333V)
R4	7030003240	Resistor	ERJ3GEYJ 22 Ω (220V)
R5	7030003280	Resistor	ERJ3GEYJ 47 Ω (470V)
R6	7030003620	Resistor	ERJ3GEYJ 33k Ω (333V)
R7	7030003400	Resistor	ERJ3GEYJ 470 Ω (471V)
R8	7030003280	Resistor	ERJ3GEYJ 47 Ω (470V)
R11	7030003440	Resistor	ERJ3GEYJ 1k Ω (102V)
R12	7030003440	Resistor	ERJ3GEYJ 1k Ω (102V)
R13	7030003700	Resistor	ERJ3GEYJ 150k Ω (154V)
R14	7030003660	Resistor	ERJ3GEYJ 68k Ω (683V)
R15	7030003560	Resistor	ERJ3GEYJ 10k Ω (103V)
R16	7030003560	Resistor	ERJ3GEYJ 10k Ω (103V)
R17	7030003340	Resistor	ERJ3GEYJ 150 Ω (151V)
C1	4030006850	Ceramic	C1608 JB 1H 471K-T-A
C2	4030006850	Ceramic	C1608 JB 1H 471K-T-A
C3	4030006660	Ceramic	C1608 SL 1H 220J-T-A
C4	4030006850	Ceramic	C1608 JB 1H 471K-T-A
C5	4030006850	Ceramic	C1608 JB 1H 471K-T-A
C6	4030006850	Ceramic	C1608 JB 1H 471K-T-A
C7	4030006850	Ceramic	C1608 JB 1H 471K-T-A
C8	4030006860	Ceramic	C1608 JB 1H 102K-T-A
C9	4030006510	Ceramic	C1608 SL 1H 0R5C-T-A
C10	4030006660	Ceramic	C1608 SL 1H 220J-T-A
C11	4030006850	Ceramic	C1608 JB 1H 471K-T-A
C12	4030006610	Ceramic	C1608 SL 1H 100D-T-A
C13	4030006850	Ceramic	C1608 JB 1H 471K-T-A
C14	4030006850	Ceramic	C1608 JB 1H 471K-T-A
C15	4030006530	Ceramic	C1608 SL 1H 020C-T-A
C17	4030006850	Ceramic	C1608 JB 1H 471K-T-A
EP1	0910021611	P.C. Board	B 2089A (U·RF)
EP3	6910003110	Lead Frame	HFB2.0-0.7-8 (N)

[UHF COL UNIT]

REF. NO.	ORDER NO.	DESCRIPTION	
L1	6190000320	Coil	F367PN-157A
L2	6190000320	Coil	F367PN-157A
L3	6150003210	Coil	LS-319
EP1	0910021621	P.C. Board	B 2099A (U-CQL)

[VHF COL UNIT]

REF. NO.	ORDER NO.	DESCRIPTION	
L1	6150003120	Coil	LS-321
L2	6150003120	Coil	LS-321
L3	6150003430	Coil	LS-378
L4	6150003210	Coil	LS-319
EP1	0910023061	P.C. Board	B 2098A (V-COL)

[VHF RF UNIT]

REF. NO.	ORDER NO.	DESCRIPTION			
Q1	1530002570	Transistor	2SC4405-3-TR		
Q2	1530002560	Transistor	2SC4403-3-TR		
Q3	1560000550	FET	2SK882-Y (TE85R)		
D1	1790000620	Diode	MA77	(TW)	
D2	1790000640	Diode	MA363B	(TX)	
D3	1790000620	Diode	MA77	(TW)	
D4	1790000640	Diode	MA363B	(TX)	
D5	1790000640	Diode	MA363B	(TX)	
D6	1790000620	Diode	MA77	(TW)	
D7	1790000620	Diode	MA77	(TW)	
R1	7030003560	Resistor	ERJ3GEYJ	10k Ω	(103V)
R2	7030003680	Resistor	ERJ3GEYJ	100k Ω	(104V)
R3	7030003560	Resistor	ERJ3GEYJ	10k Ω	(103V)
R4	7030003330	Resistor	ERJ3GEYJ	120 Ω	(121V)
R5	7030003240	Resistor	ERJ3GEYJ	22 Ω	(220V)
R6	7030003580	Resistor	ERJ3GEYJ	15k Ω	(153V)
R7	7030003520	Resistor	ERJ3GEYJ	4.7k Ω	(472V)
R8	7030003280	Resistor	ERJ3GEYJ	47 Ω	(470V)
R9	7030003560	Resistor	ERJ3GEYJ	10k Ω	(103V)
R10	7030003680	Resistor	ERJ3GEYJ	100k Ω	(104V)
R11	7030003680	Resistor	ERJ3GEYJ	100k Ω	(104V)
R12	7030003560	Resistor	ERJ3GEYJ	10k Ω	(103V)
R13	7030003480	Resistor	ERJ3GEYJ	2.2k Ω	(222V)
R14	7030003290	Resistor	ERJ3GEYJ	56 Ω	(560V)
R15	7030003520	Resistor	ERJ3GEYJ	4.7k Ω	(472V)
R16	7030003480	Resistor	ERJ3GEYJ	2.2k Ω	(222V)
R17	7030003520	Resistor	ERJ3GEYJ	4.7k Ω	(472V)
C1	4030006590	Ceramic	C1608 SL 1H	080D-T-A	
C2	4030006620	Ceramic	C1608 SL 1H	120J-T-A	
C3	4030006640	Ceramic	C1608 SL 1H	180J-T-A	
C4	4030006690	Ceramic	C1608 SL 1H	330J-T-A	
C5	4030006860	Ceramic	C1608 JB 1H	102K-T-A	
C6	4030006860	Ceramic	C1608 JB 1H	102K-T-A	
C7	4030006860	Ceramic	C1608 JB 1H	102K-T-A	
C8	4030006590	Ceramic	C1608 SL 1H	080D-T-A	
C9	4030006720	Ceramic	C1608 SL 1H	560J-T-A	
C10	4030006580	Ceramic	C1608 SL 1H	070D-T-A	
C11	4030008570	Ceramic	C1608 SL 1H	R75C-T-A	
C12	4030006720	Ceramic	C1608 SL 1H	560J-T-A	
C13	4030006590	Ceramic	C1608 SL 1H	080D-T-A	
C14	4030006860	Ceramic	C1608 JB 1H	102K-T-A	
C15	4030006860	Ceramic	C1608 JB 1H	102K-T-A	
C16	4030006860	Ceramic	C1608 JB 1H	102K-T-A	
C17	4030006710	Ceramic	C1608 SL 1H	470J-T-A	
C18	4030006660	Ceramic	C1608 SL 1H	220J-T-A	
C19	4030006860	Ceramic	C1608 JB 1H	102K-T-A	
C20	4030006860	Ceramic	C1608 JB 1H	102K-T-A	
C21	4030006610	Ceramic	C1608 SL 1H	100D-T-A	
C22	4030006860	Ceramic	C1608 JB 1H	102K-T-A	
EP1	6910003110	Lead Frame	HFB2.0-0.7-8 (N)		
EP2	0910023052	P.C. Board	B 2088B (V-RF)		

[UHF PLL UNIT]

REF. NO.	ORDER NO.	DESCRIPTION			
IC1	1120001550	IC	M54959FP		
IC2	1130004200	IC	TC4S66F (TE85R)		
Q1	1530002560	Transistor	2SC4403-3-TR		
Q2	1530002560	Transistor	2SC4403-3-TR		
Q3	1530002560	Transistor	2SC4403-3-TR		
Q4	1530002280	Transistor	2SC4081 S T107		
Q5	1530002280	Transistor	2SC4081 S T107		
Q6	1590000680	Transistor	DTC114EU T107		
Q7	1590000720	Transistor	DTA114EU T107		
L1	6200000110	Coil	LQN 2A 33NM		
L2	6200000090	Coil	LQN 2A 18NM		
L3	6200000090	Coil	LQN 2A 18NM		
R1	7030003400	Resistor	ERJ3GEYJ	470 Ω	(471V)
R2	7030003650	Resistor	ERJ3GEYJ	56k Ω	(563V)
R4	7030003440	Resistor	ERJ3GEYJ	1k Ω	(102V)
R5	7030003320	Resistor	ERJ3GEYJ	100 Ω	(101V)
R6	7030003630	Resistor	ERJ3GEYJ	39k Ω	(393V)
R7	7030003630	Resistor	ERJ3GEYJ	39k Ω	(393V)
R8	7030003360	Resistor	ERJ3GEYJ	220 Ω	(221V)
R9	7030003480	Resistor	ERJ3GEYJ	2.2k Ω	(222V)
R10	7030003520	Resistor	ERJ3GEYJ	4.7k Ω	(472V)
R11	7030003540	Resistor	ERJ3GEYJ	6.8k Ω	(682V)
R12	7030003590	Resistor	ERJ3GEYJ	18k Ω	(183V)
R13	7030003740	Resistor	ERJ3GEYJ	330k Ω	(334V)
R15	7030003600	Resistor	ERJ3GEYJ	22k Ω	(223V)
R16	7030003440	Resistor	ERJ3GEYJ	1k Ω	(102V)
C1	4030006860	Ceramic	C1608 JB 1H	102K-T-A	
C2	4030006550	Ceramic	C1608 SL 1H	040C-T-A	
C3	4030006850	Ceramic	C1608 JB 1H	471K-T-A	
C4	4030004760	Ceramic	C2012 JF 1E	104Z-T-A	
C5	4030006850	Ceramic	C1608 JB 1H	471K-T-A	
C6	4030004760	Ceramic	C2012 JF 1E	104Z-T-A	
C7	4550000460	Tantalum	TESVA 1C	105M1-8L	
C8	4030006590	Ceramic	C1608 SL 1H	080D-T-A	
C9	4030008440	Ceramic	C1608 SL 1H	1R5C-T-A	
C10	4030006850	Ceramic	C1608 JB 1H	471K-T-A	
C11	4030006850	Ceramic	C1608 JB 1H	471K-T-A	
C12	4030006580	Ceramic	C1608 SL 1H	070D-T-A	
C13	4030006540	Ceramic	C1608 SL 1H	030C-T-A	
C14	4030006860	Ceramic	C1608 JB 1H	102K-T-A	
C15	4550000460	Tantalum	TESVA 1C	105M1-8L	
C16	4030004760	Ceramic	C2012 JF 1E	104Z-T-A	
C17	4550000270	Tantalum	TESVA 1E	474M1-8L	
C18	4030006900	Ceramic	C1608 JB 1E	103K-T-A	
C19	4030004760	Ceramic	C2012 JF 1E	104Z-T-A	
C20	4030006750	Ceramic	C1608 SL 1H	101J-T-A	
C21	4030006560	Ceramic	C1608 SL 1H	050C-T-A	
C22	4550003030	Tantalum	TEMSVA 0J	475M-8L	
EP1	0910023044	P.C. Board	B 2087D (U-PLL)		

[VHF PLL UNIT]

REF. NO.	ORDER NO.	DESCRIPTION	
K1	1120001550	IC	M54959FP
K2	1130004200	IC	TC4S66F (TE85R)
Q1	1590000970	Transistor	FMA2 T148
Q2	1560000340	FET	2SK210-Y (TE85R)
Q3	1560000540	FET	2SK880-Y (TE85R)
Q4	1560000540	FET	2SK880-Y (TE85R)
Q5	1560000430	FET	2SK302-GR (TE85R)
Q6	1530002560	Transistor	2SC4403-3-TR
Q7	1530002560	Transistor	2SC4403-3-TR
Q8	1530002560	Transistor	2SC4403-3-TR
Q9	1590000440	Transistor	DTA143ZU T107
Q10	1590000430	Transistor	DTC144EU T107
D1	1790000530	Diode	MA333 (TW)
D2	1790000540	Diode	MA338 (TX)
D3	1790000660	Diode	MA728 (TW)
L1	6110002590	Coil	LA-239
L2	6200000860	Coil	LQH 3N 1R8M
L3	6110002150	Coil	LA-385
L4	6200000820	Coil	LQH 3N R82M
L5	6200000260	Coil	LQN 2A R10K
L6	6200000260	Coil	LQN 2A R10K
R1	7030003480	Resistor	ERJ3GEYJ 2.2k $\Omega$ (222V)
R2	7030003550	Resistor	ERJ3GEYJ 8.2k $\Omega$ (822V)
R3	7030003500	Resistor	ERJ3GEYJ 3.3k $\Omega$ (332V)
R4	7030003720	Resistor	ERJ3GEYJ 220k $\Omega$ (224V)
R5	7030003400	Resistor	ERJ3GEYJ 470 $\Omega$ (471V)
R6	7030003560	Resistor	ERJ3GEYJ 10k $\Omega$ (103V)
R7	7030003450	Resistor	ERJ3GEYJ 1.2k $\Omega$ (122V)
R8	7030003320	Resistor	ERJ3GEYJ 100 $\Omega$ (101V)
R9	7030003200	Resistor	ERJ3GEYJ 10 $\Omega$ (100V)
R10	7030003280	Resistor	ERJ3GEYJ 47 $\Omega$ (470V)
R11	7030003450	Resistor	ERJ3GEYJ 1.2k $\Omega$ (122V)
R12	7030003200	Resistor	ERJ3GEYJ 10 $\Omega$ (100V)
R14	7030003630	Resistor	ERJ3GEYJ 39k $\Omega$ (393V)
R15	7030003410	Resistor	ERJ3GEYJ 560 $\Omega$ (561V)
R16	7030003660	Resistor	ERJ3GEYJ 68k $\Omega$ (683V)
R17	7030003420	Resistor	ERJ3GEYJ 680 $\Omega$ (681V)
R18	7030003650	Resistor	ERJ3GEYJ 56k $\Omega$ (563V)
R19	7030003390	Resistor	ERJ3GEYJ 390 $\Omega$ (391V)
R20	7030003320	Resistor	ERJ3GEYJ 100 $\Omega$ (101V)
R21	7030003610	Resistor	ERJ3GEYJ 27k $\Omega$ (273V)
C1	4030006860	Ceramic	C1608 JB 1H 102K-T-A
C2	4030006860	Ceramic	C1608 JB 1H 102K-T-A
C3	4030004760	Ceramic	C2012 JF 1E 104Z-T-A
C4	4030004760	Ceramic	C2012 JF 1E 104Z-T-A
C5	4030004760	Ceramic	C2012 JF 1E 104Z-T-A
C6	4550000460	Tantalum	TESVA 1C 105M1-8L
C7	4030006900	Ceramic	C1608 JB 1E 103K-T-A
C8	4030006760	Ceramic	C1608 SL 1H 121J-T-A
C9	4030006560	Ceramic	C1608 SL 1H 050C-T-A
C10	4030006560	Ceramic	C1608 SL 1H 050C-T-A
C12	4030006510	Ceramic	C1608 SL 1H 0R5C-T-A
C13	4030006860	Ceramic	C1608 JB 1H 102K-T-A
C14	4030006750	Ceramic	C1608 SL 1H 101J-T-A
C15	4030006540	Ceramic	C1608 SL 1H 030C-T-A
C16	4030006570	Ceramic	C1608 SL 1H 060D-T-A
C17	4030006510	Ceramic	C1608 SL 1H 0R5C-T-A
C18	4030006860	Ceramic	C1608 JB 1H 102K-T-A
C19	4030006710	Ceramic	C1608 SL 1H 470J-T-A
C20	4030004760	Ceramic	C2012 JF 1E 104Z-T-A
C21	4030006550	Ceramic	C1608 SL 1H 040C-T-A
C22	4030006580	Ceramic	C1608 SL 1H 070D-T-A
C23	4030006580	Ceramic	C1608 SL 1H 070D-T-A
C24	4030006660	Ceramic	C1608 SL 1H 220J-T-A
C25	4030006560	Ceramic	C1608 SL 1H 050C-T-A
C26	4030006510	Ceramic	C1608 SL 1H 0R5C-T-A
C27	4030006510	Ceramic	C1608 SL 1H 0R5C-T-A
C28	4030006510	Ceramic	C1608 SL 1H 0R5C-T-A
C29	4030006850	Ceramic	C1608 JB 1H 471K-T-A
C30	4030006860	Ceramic	C1608 JB 1H 102K-T-A
C31	4030006850	Ceramic	C1608 JB 1H 471K-T-A

[VHF PLL UNIT]

REF. NO.	ORDER NO.	DESCRIPTION	
C32	4030006710	Ceramic	C1608 SL 1H 470J-T-A
C33	4030006850	Ceramic	C1608 JB 1H 471K-T-A
C34	4030006560	Ceramic	C1608 SL 1H 050C-T-A
C36	4030006710	Ceramic	C1608 SL 1H 470J-T-A
C37	4030006850	Ceramic	C1608 JB 1H 471K-T-A
C38	4030006850	Ceramic	C1608 JB 1H 471K-T-A
C39	4030006850	Ceramic	C1608 JB 1H 471K-T-A
EP1	0910023033	P.C. Board	B 2086C (V-PLL)

[UHF VCO UNIT]

REF. NO.	ORDER NO.	DESCRIPTION	
Q1	1530000371	Transistor	2SC3356 R25-T2B
D1	1790000530	Diode	MA333 (TW)
D2	1790000620	Diode	MA77 (TW)
D3	1790000620	Diode	MA77 (TW)
L1	6110002000	Coil	LA-226
L2	6200000360	Coil	MLF3216D R33M-T
L3	6200001040	Coil	MLF2012E 6R8M-T
R3	7030003720	Resistor	ERJ3GEYJ 220k $\Omega$ (224V)
R4	7030003580	Resistor	ERJ3GEYJ 15k $\Omega$ (153V)
R5	7030003580	Resistor	ERJ3GEYJ 15k $\Omega$ (153V)
R6	7030003640	Resistor	ERJ3GEYJ 47k $\Omega$ (473V)
R7	7030003540	Resistor	ERJ3GEYJ 6.8k $\Omega$ (682V)
R8	7030003360	Resistor	ERJ3GEYJ 220 $\Omega$ (221V)
R9	7030003520	Resistor	ERJ3GEYJ 4.7k $\Omega$ (472V)
R10	7030003350	Resistor	ERJ3GEYJ 180 $\Omega$ (181V)
C1	4030006910	Ceramic	C1608 CH 1H 0R5C-T-A
C2	4030006900	Ceramic	C1608 JB 1E 103K-T-A
C3	4610001260	Trimmer	ECRJA020E12W
C4	4030007010	Ceramic	C1608 CH 1H 100D-T-A
C5	4030007030	Ceramic	C1608 CH 1H 150J-T-A
C6	4030006850	Ceramic	C1608 JB 1H 471K-T-A
C7	4030007010	Ceramic	C1608 CH 1H 100D-T-A
C8	4030006850	Ceramic	C1608 JB 1H 471K-T-A
C9	4030006850	Ceramic	C1608 JB 1H 471K-T-A
C10	4030007020	Ceramic	C1608 CH 1H 120J-T-A
C11	4550000460	Tantalum	TESVA 1C 105M1-8L
C12	4030007010	Ceramic	C1608 CH 1H 100D-T-A
C13	4030006920	Ceramic	C1608 CH 1H 010C-T-A
C14	4030006930	Ceramic	C1608 CH 1H 020C-T-A
EP1	0910022924	P.C. Board	B 2241D (U-VCO)

[VR UNIT]

REF. NO.	ORDER NO.	DESCRIPTION	
R1	7210001440	Variable Resistor	RK097111101NA (10KA)
R2	7210001450	Variable Resistor	RK0971110051A (10KB)
EP1	0910021713	P.C. Board	B 2093C (VR)

[LPF UNIT]

REF. NO.	ORDER NO.	DESCRIPTION	
D1	1790000490	Diode	HSM88AS-TR
L1	6110002110	Coil	LA-382
L2	6110001990	Coil	LA-223
L3	6110002130	Coil	LA-383
R1	7030003370	Resistor	ERJ3GEYJ 270 Ω (271V)
R2	7030003470	Resistor	ERJ3GEYJ 1.8k Ω (182V)
C1	4030006570	Ceramic	C1608 SL 1H 060D-T-A
C2	4030008440	Ceramic	C1608 SL 1H 1R5C-T-A
C3	4030006590	Ceramic	C1608 SL 1H 080D-T-A
C4	4030006510	Ceramic	C1608 SL 1H 0R5C-T-A
C5	4030006570	Ceramic	C1608 SL 1H 060D-T-A
C7	4030006860	Ceramic	C1608 JB 1H 102K-T-A
C8	4030006850	Ceramic	C1608 JB 1H 471K-T-A
EP1	0910021384	P.C. Board	B 2038D (LPF)
EP2	6910003110	Lead Frame	HFB2.0-0.7-8 (N)

[HPF UNIT]

REF. NO.	ORDER NO.	DESCRIPTION	
D1	1750000080	Diode	1SS153-T2
D2	1790000450	Diode	MA862 (TX)
D3	1790000490	Diode	HSM88AS-TR
L1	6110002010	Coil	LA-224
L2	6110002040	Coil	LA-225
L3	6110002070	Coil	LA-227
L4	6110002070	Coil	LA-227
L5	6110002070	Coil	LA-227
L6	6110002000	Coil	LA-226
L7	6110002000	Coil	LA-226
L8	6200000060	Coil	LQH 3N 1R5M
R1	7030003340	Resistor	ERJ3GEYJ 150 Ω (151V)
R2	7030003440	Resistor	ERJ3GEYJ 1k Ω (102V)
C1	4030006580	Ceramic	C1608 SL 1H 070D-T-A
C2	4030006550	Ceramic	C1608 SL 1H 040C-T-A
C3	4030006590	Ceramic	C1608 SL 1H 080D-T-A
C4	4030006690	Ceramic	C1608 SL 1H 330J-T-A
C5	4030006610	Ceramic	C1608 SL 1H 100D-T-A
C6	4030006660	Ceramic	C1608 SL 1H 220J-T-A
C7	4030006570	Ceramic	C1608 SL 1H 060D-T-A
C8	4030006660	Ceramic	C1608 SL 1H 220J-T-A
C9	4030006540	Ceramic	C1608 SL 1H 030C-T-A
C10	4030006620	Ceramic	C1608 SL 1H 120J-T-A
C11	4030006860	Ceramic	C1608 JB 1H 102K-T-A
C12	4030006640	Ceramic	C1608 SL 1H 180J-T-A
C13	4030006690	Ceramic	C1608 SL 1H 330J-T-A
C14	4030006630	Ceramic	C1608 SL 1H 150J-T-A
C15	4030006860	Ceramic	C1608 JB 1H 102K-T-A
C16	4030006850	Ceramic	C1608 JB 1H 471K-T-A
C17	4030006850	Ceramic	C1608 JB 1H 471K-T-A
C18	4030006510	Ceramic	C1608 SL 1H 0R5C-T-A
C19	4030006540	Ceramic	C1608 SL 1H 030C-T-A
EP1	0910021554	P.C. Board	B 2036D (HPF)
EP2	6910003110	Lead Frame	HFB2.0-0.7-8 (N)

[UHF SW UNIT]

REF. NO.	ORDER NO.	DESCRIPTION	
D1	1790000450	Diode	MA862 (TX)
L1	6200000090	Coil	LQN 2A 18NM
L2	6200000090	Coil	LQN 2A 18NM
L3	6200000090	Coil	LQN 2A 18NM
C1	4030006560	Ceramic	C1608 SL 1H 050C-T-A
C2	4030006630	Ceramic	C1608 SL 1H 150J-T-A
C3	4030006570	Ceramic	C1608 SL 1H 060D-T-A
C4	4030006580	Ceramic	C1608 SL 1H 070D-T-A
C5	4030006580	Ceramic	C1608 SL 1H 070D-T-A
EP1	0910023212	P.C. Board	B 2256B (U-SW)
EP2	6910003110	Lead Frame	HFB2.0-0.7-8 (N)

[UHF YGR UNIT]

REF. NO.	ORDER NO.	DESCRIPTION	
IC1	1150000720		SC1097
Q1	1530002340	Transistor	2SC2954-T2B
Q2	1520000080	Transistor	2SB909M R
Q3	1590000430	Transistor	DTC144EU T107
Q4	1590000430	Transistor	DTC144EU T107
D2	1750000080	Diode	1SS153-T2
D3	1790000450	Diode	MA862 (TX)
D4	1790000490	Diode	HSM88AS-TR
L1	6200000100	Coil	LQN 2A 22NM
L2	6200000910	Coil	LQN 2A 82NM
L3	6110001990	Coil	LA-223
R1	7030003200	Resistor	ERJ3GEYJ 10 Ω (100V)
R2	7510000200	Thermistor	DTN-T203U473LS(T)
R3	7310002580	Trimmer	RV-108 (RH03 A3A15X05A) 104
R4	7310002580	Trimmer	RV-108 (RH03 A3A15X05A) 104
R5	7030003600	Resistor	ERJ3GEYJ 22k Ω (223V)
R7	7030003320	Resistor	ERJ3GEYJ 100 Ω (101V)
R8	7030003600	Resistor	ERJ3GEYJ 22k Ω (223V)
R9	7030003440	Resistor	ERJ3GEYJ 1k Ω (102V)
C1	4030006850	Ceramic	C1608 JB 1H 471K-T-A
C2	4030006540	Ceramic	C1608 SL 1H 030C-T-A
C3	4030006850	Ceramic	C1608 JB 1H 471K-T-A
C4	4030006850	Ceramic	C1608 JB 1H 471K-T-A
C5	4030006850	Ceramic	C1608 JB 1H 471K-T-A
C6	4510003740	Electrolytic	6.3 RC3 10 μF (3X5)
C7	4510003390	Electrolytic	16 RC3 47 μF
C8	4030006850	Ceramic	C1608 JB 1H 471K-T-A
C10	4030006850	Ceramic	C1608 JB 1H 471K-T-A
C11	4030006580	Ceramic	C1608 SL 1H 070D-T-A
C12	4030006600	Ceramic	C1608 SL 1H 090D-T-A
C13	4030006850	Ceramic	C1608 JB 1H 471K-T-A
C15	4030006510	Ceramic	C1608 SL 1H 0R5C-T-A
C16	4030006540	Ceramic	C1608 SL 1H 030C-T-A
EP1	0910021563	P.C. Board	B 2037C (U-YGR)

[LOGIC UNIT]

REF. NO.	ORDER NO.	DESCRIPTION	
IC1	1140001430	IC	HD404608A48H
IC2	1120000430	IC	LA6393M-TP-T1
IC3	1180000550	IC	RH5VA37CA-T1
IC4	1130003760	IC	TC4S81F (TE85R)
IC6	1130000830	IC	$\mu$ PD4094BG-T1
Q1	1530002060	Transistor	2SC4081 R T107
Q2	1530002060	Transistor	2SC4081 R T107
Q3	1590000690	Transistor	MD6 T108
Q5	1560000540	FET	2SK880-Y (TE85R)
Q6	1530002060	Transistor	2SC4081 R T107
Q7	1530002060	Transistor	2SC4081 R T107
D2	1730002160	Zener	02CZ5.1-Z (TE85R)
D3	1160000060	Diode	DAN202U T107
D4	1750000130	Diode	DA204U T107
D5	1160000060	Diode	DAN202U T107 (SEA)
	1750000160	Diode	DA114 T107 (AUS)
	1750000170	Diode	DA115 T107 (EUR, UK, USA)
D6	1750000170	Diode	DA115 T107 (ITA, USA, AUS, SEA)
D7	1750000130	Diode	DA204U T107 (ITA)
D8	1750000160	Diode	DA114 T107 (EUR, UK, USA, AUS)
D9	1750000120	Diode	DWA010-TE
D10	1750000120	Diode	DWA010-TE
D12	1750000130	Diode	DA204U T107 (ITA)
D14	1710000600	Diode	1SS254
D15	1160000060	Diode	DAN202U T107
D17	1160000060	Diode	DAN202U T107
D18	1790000590	Diode	MA110 (TW)
D19	1750000130	Diode	DA204U T107
D20	1750000190	Diode	1SS322 (TE85R)
X1	6050005800	Crystal	DT-26S 32.768kHz
X2	6060000390	Crystal	CSB800J201
R1	7030003800	Resistor	ERJ3GEYJ 1M $\Omega$ (105V)
R2	7030003640	Resistor	ERJ3GEYJ 47k $\Omega$ (473V)
R3	7030003640	Resistor	ERJ3GRYJ 47k $\Omega$ (473V)
R4	7030003640	Resistor	ERJ3GEYJ 47k $\Omega$ (473V)
R5	7030003640	Resistor	ERJ3GEYJ 47k $\Omega$ (473V)
R6	7030003640	Resistor	ERJ3GEYJ 47k $\Omega$ (473V)
R7	7030003640	Resistor	ERJ3GEYJ 47k $\Omega$ (473V)
R8	7030003640	Resistor	ERJ3GEYJ 47k $\Omega$ (473V)
R9	7030003640	Resistor	ERJ3GEYJ 47k $\Omega$ (473V)
R10	7030003720	Resistor	ERJ3GEYJ 220k $\Omega$ (224V)
R11	7030003800	Resistor	ERJ3GEYJ 1M $\Omega$ (105V)
R12	7030003800	Resistor	ERJ3GEYJ 1M $\Omega$ (105V)
R13	7030003800	Resistor	ERJ3GEYJ 1M $\Omega$ (105V)
R14	7030003800	Resistor	ERJ3GEYJ 1M $\Omega$ (105V)
R15	7030003720	Resistor	ERJ3GEYJ 220k $\Omega$ (224V)
R16	7030003720	Resistor	ERJ3GEYJ 220k $\Omega$ (224V)
R17	7030003840	Resistor	ERJ3GEYJ 2.2M $\Omega$ (225V)
R18	7030003720	Resistor	ERJ3GEYJ 220k $\Omega$ (224V)
R19	7030003720	Resistor	ERJ3GEYJ 220k $\Omega$ (224V)
R20	7030003720	Resistor	ERJ3GEYJ 220k $\Omega$ (224V)
R24	7030003620	Resistor	ERJ3GEYJ 33k $\Omega$ (333V)
R25	7030003760	Resistor	ERJ3GEYJ 470k $\Omega$ (474V)
R26	7030003680	Resistor	ERJ3GEYJ 100k $\Omega$ (104V)
R27	7030003720	Resistor	ERJ3GEYJ 220k $\Omega$ (224V)
R28	7030003750	Resistor	ERJ3GEYJ 390k $\Omega$ (394V)
R29	7030003790	Resistor	ERJ3GEYJ 820k $\Omega$ (824V)
R33	7030003340	Resistor	ERJ3GEYJ 150 $\Omega$ (151V)
R34	7030003350	Resistor	ERJ3GEYJ 180 $\Omega$ (181V)
R35	7030003640	Resistor	ERJ3GEYJ 47k $\Omega$ (473V)
R37	7030003530	Resistor	ERJ3GEYJ 5.6k $\Omega$ (562V)
R38	7030003550	Resistor	ERJ3GEYJ 8.2k $\Omega$ (822V)
R39	7030003330	Resistor	ERJ3GEYJ 120 $\Omega$ (121V)
R40	7030003620	Resistor	ERJ3GEYJ 33k $\Omega$ (333V)
R41	7030003800	Resistor	ERJ3GEYJ 1M $\Omega$ (105V)
R42	7030003800	Resistor	ERJ3GEYJ 1M $\Omega$ (105V)
R43	7030003640	Resistor	ERJ3GEYJ 47k $\Omega$ (473V)
R44	7030003560	Resistor	ERJ3GEYJ 10k $\Omega$ (103V)
R45	7030003580	Resistor	ERJ3GEYJ 15k $\Omega$ (153V)
R46	7030003610	Resistor	ERJ3GEYJ 27k $\Omega$ (273V)
R47	7030003600	Resistor	ERJ3GEYJ 22k $\Omega$ (223V)

[LOGIC UNIT]

REF. NO.	ORDER NO.	DESCRIPTION	
R52	7030003560	Resistor	ERJ3GEYJ 10k $\Omega$ (103V)
R53	7030003380	Resistor	ERJ3GEYJ 330 $\Omega$ (331V)
R54	7030003800	Resistor	ERJ3GETJ 1M $\Omega$ (105V)
R55	7030003580	Resistor	ERJ3GEYJ 15k $\Omega$ (153V)
R56	7030003580	Resistor	ERJ3GEYJ 15k $\Omega$ (153V)
R57	7030003760	Resistor	ERJ3GEYJ 470k $\Omega$ (474V)
R58	7310002600	Trimmer	RV-110 (RH03 A3AS4X0AA) 473
R59	7030003560	Resistor	ERJ3GEYJ 10k $\Omega$ (103V)
R60	7310002740	Trimmer	RV-150 (RH03 A3A14X0FC) 103
R61	7030003800	Resistor	ERJ3GEYJ 1M $\Omega$ (105V) (EUR, UK, ITA)
R62	7030003640	Resistor	ERJ3GEYJ 47k $\Omega$ (473V) (EUR, UK, ITA)
R63	7030003200	Resistor	ERJ3GEYJ 10 $\Omega$ (100V)
R64	7030003800	Resistor	ERJ3GEYJ 1M $\Omega$ (105V)
R65	7030003760	Resistor	ERJ3GEYJ 470k $\Omega$ (474V)
R66	7030003460	Resistor	ERJ3GEYJ 1.5k $\Omega$ (152V)
R67	7030003760	Resistor	ERJ3GEYJ 470k $\Omega$ (474V)
R68	7030003800	Resistor	ERJ3GEYJ 1M $\Omega$ (105V)
R69	7030003480	Resistor	ERJ3GEYJ 2.2k $\Omega$ (222V)
R70	7030003470	Resistor	ERJ3GEYJ 1.8k $\Omega$ (182V)
R71	7510000180	Thermistor	DTN-T203S223LS(T)
R72	7030003800	Resistor	ERJ3GEYJ 1M $\Omega$ (105V)
C1	4030007030	Ceramic	C1608 CH 1H 150J-T-A
C2	4030007030	Ceramic	C1608 CH 1H 150J-T-A
C5	4030006710	Ceramic	C1608 SL 1H 470J-T-A
C8	4030006850	Ceramic	C1608 JB 1H 471K-T-A
C9	4030006850	Ceramic	C1608 JB 1H 471K-T-A
C10	4030006850	Ceramic	C1608 JB 1H 471K-T-A
C15	4030004760	Ceramic	C2012 JF 1E 104Z-T-A
C16	4030006850	Ceramic	C1608 JB 1H 471K-T-A
C17	4030006800	Ceramic	C1608 SL 1H 221J-T-A
C18	4030006710	Ceramic	C1608 SL 1H 470J-T-A
C20	4550000770	Tantalum	TESVC 0J 226M-12L
C21	4030006850	Ceramic	C1608 JB 1H 471K-T-A
C22	4030004760	Ceramic	C2012 JF 1E 104Z-T-A
C23	4030004760	Ceramic	C2012 JF 1E 104Z-T-A
C24	4030006850	Ceramic	C1608 JB 1H 471K-T-A
C25	4030006860	Ceramic	C1608 JB 1H 102K-T-A
C26	4030004760	Ceramic	C2012 JF 1E 104Z-T-A
C27	4030006850	Ceramic	C1608 JB 1H 471K-T-A
C28	4030006860	Ceramic	C1608 JB 1H 102K-T-A
C29	4030006850	Ceramic	C1608 JB 1H 471K-T-A
C30	4030006710	Ceramic	C1608 SL 1H 470J-T-A
C31	4030006710	Ceramic	C1608 SL 1H 470J-T-A
C32	4030006710	Ceramic	C1608 SL 1H 470J-T-A
C33	4030006710	Ceramic	C1608 SL 1H 470J-T-A
C35	4030006710	Ceramic	C1608 SL 1H 470J-T-A
C36	40300067	Ceramic	C1608 SL 1H 470J-T-A
DS1	5030000480	LCD	LD-BU9394J (E-5057)
DS2	5040000950	LED	SLM-13DWS T97B
DS3	5040000950	LED	SLM-13DWS T97B
DS4	5040001110	LED	SLM-23VMWS T97B
MC1	7700000860	Mic element	WM-62A
S1	2260001310	Switch	SW-120 (SKHUPD)
S2	2260001310	Switch	SW-120 (SKHUPD)
SP1	2510000450	Speaker	EAS-3P123D
BT1	3020000160	Lithium Battery	VL2020-1VC
EP1	0910023743	P.C. Board	B 2290C (LOGIC)
EP6	8930016260	LCD contact strip	SRCN-758
EP7	0910024250	P.C. Board	B 2319 (Key Board)
EP8	6910003420	Lead Frame	AR1.27-0.7-12.3

**[PRT UNIT]**

REF. NO.	ORDER NO.	DESCRIPTION			
Q1	1520000200	Transistor	2SB798-DK-T2		
Q2	1530002280	Transistor	2SC4081 S T107		
D1	1790000680	Diode	SB29-03P-TD		
D2	1790000670	Diode	SB07-03C-TA		
D5	1790000590	Diode	MA110 (TW)		
D6	1730002160	Zener	02CZ5.1-Z (TE85R)		
R1	7030003250	Resistor	ERJ3GEYJ	27 Ω	(270V)
R2	7030003380	Resistor	ERJ3GEYJ	330 Ω	(331V)
R3	7030003440	Resistor	ERJ3GEYJ	1k Ω	(102V)
R4	7030003600	Resistor	ERJ3GEYJ	22k Ω	(223V)
R5	7030003470	Resistor	ERJ3GEYJ	1.8k Ω	(182V)
R6	7030003520	Resistor	ERJ3GEYJ	4.7k Ω	(472V)
R7	7030003320	Resistor	ERJ3GEYJ	100 Ω	(101V)
R8	7030003440	Resistor	ERJ3GEYJ	1k Ω	(102V)
R9	7030003250	Resistor	ERJ3GEYJ	27 Ω	(270V)
C1	4030006860	Ceramic	C1608 JB 1H	102K-T-A	
C2	4030006860	Ceramic	C1608 JB 1H	102K-T-A	
C3	4030006710	Ceramic	C1608 SL 1H	470J-T-A	
C4	4030006860	Ceramic	C1608 JB 1H	102K-T-A	
C5	4030006860	Ceramic	C1608 JB 1H	102K-T-A	
C6	4030006860	Ceramic	C1608 JB 1H	102K-T-A	
EP1	0910024152	P.C. Board	B 2253B (PRT)		

**[ADENCA UNIT]**

REF. NO.	ORDER NO.	DESCRIPTION			
D1	1160000060	Diode	DAN202U T107		
C1	4030006850	Ceramic	C1608 JB 1H	471K-T-A	
C2	4030006850	Ceramic	C1608 JB 1H	471K-T-A	
S1	2260000890	Switch	SRBM1L040A		
S2	2260001310	Switch	SW-120 (SKHUPD)		
EP1	0910023290	P.C. Board	B 2094 (ADENCA)		
EP2	0910021912	P.C. Board	B 2111B		

**[PTT UNIT]**

REF. NO.	ORDER NO.	DESCRIPTION			
S1	2260001320	Switch	SW-121 (SKHUPF)		
S2	2260001320	Switch	SW-121 (SKHUPF)		
EP1	0910024241	P.C. Board	B 2097A (PTT)		

# SECTION 6 ADJUSTMENT PROCEDURES

## 6-1 PREPARATION BEFORE SERVICING

### ■ REQUIRED TEST EQUIPMENT

EQUIPMENT	GRADE AND RANGE	EQUIPMENT	GRADE AND RANGE
AC power supply	Output voltage : 13.8 V DC Current capacity : 3 A or more	DC voltmeter	Input impedance : 50 k $\Omega$ /DC or better
RF power meter (terminated type)	Measuring range : 1~10 W Frequency range : 0.1~500 MHz Impedance : 50 $\Omega$ SWR : Less than 1.2 : 1	AC milli-voltmeter	Measuring range : 10 mV~10 V
		External speaker	Impedance : 8 $\Omega$
		Audio generator	Frequency range : 300~3000 Hz Output level : 1~500 mW
Frequency counter	Frequency range : 0.1~470 MHz Frequency accuracy : $\pm$ 1ppm or better Sensitivity : 100 mV or better	Attenuator	Power attenuation : 40 or 50 dB Capacity : 10 W or more
Oscilloscope	Frequency range : DC~20 MHz Measuring range : 0.01~10 V	Distortion meter	Measuring range : 0.1~20 %
Standard signal generator (SSG)	Frequency range : 0.1~470 MHz Output level : -127~-17 dBm (0.1 $\mu$ V~32 mV)	FM deviation meter	Frequency minimum : 470 MHz Measuring range : 0~ $\pm$ 10 kHz

### ■ CONNECTION

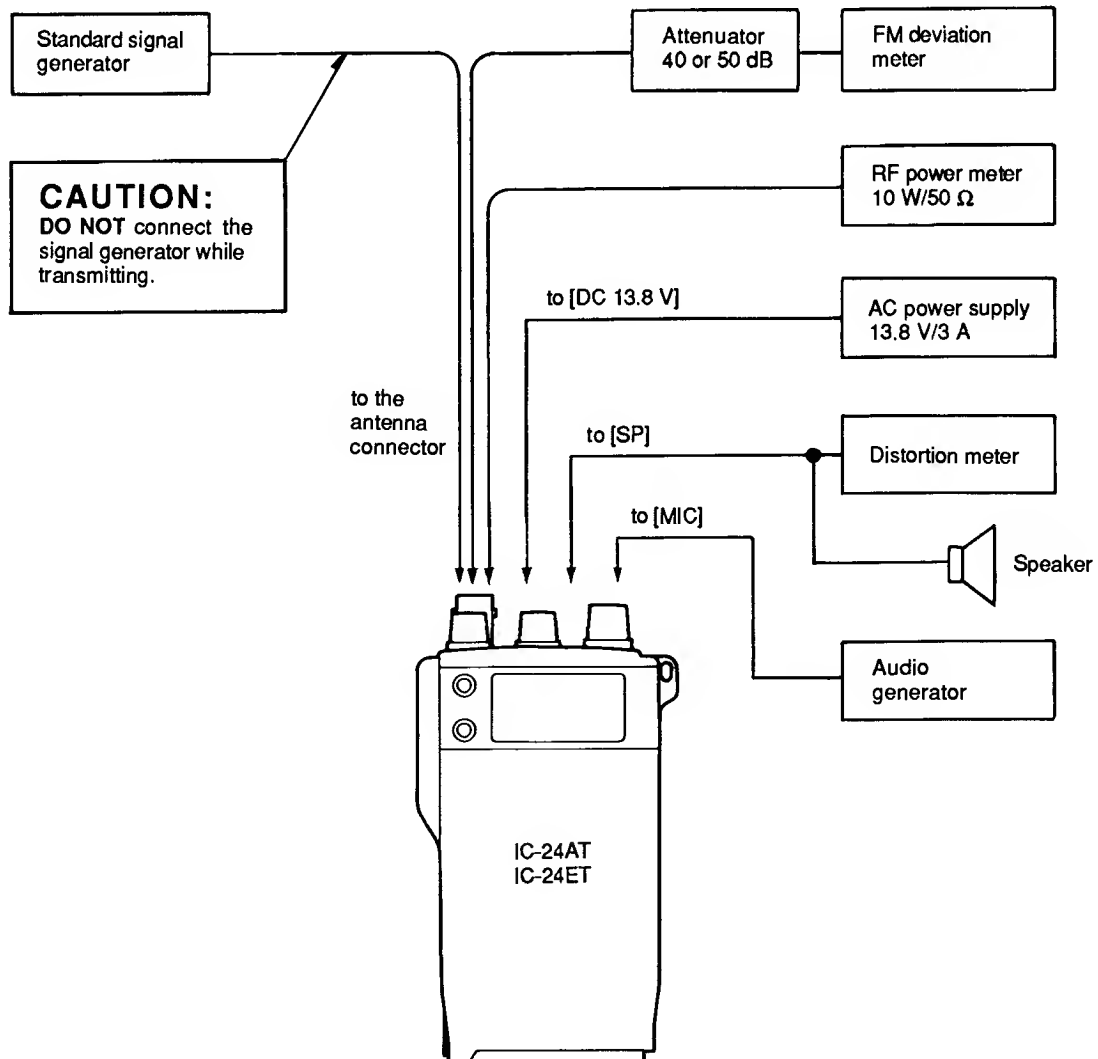



## 6-2 PLL ADJUSTMENT

ADJUSTMENT	ADJUSTMENT CONDITIONS	MEASUREMENT		VALUE	ADJUSTMENT POINT	
		UNIT	LOCATION		UNIT	ADJUST
REFERENCE FREQUENCY	1 <ul style="list-style-type: none"> <li>• Frequency display: 440.00 MHz</li> <li>• Transmitting</li> </ul>	Top panel	Loosely couple the frequency counter to the antenna connector.	440.000 MHz	MAIN	C54

## 6-3 RECEIVER ADJUSTMENT

ADJUSTMENT	ADJUSTMENT CONDITIONS	MEASUREMENT		VALUE	ADJUSTMENT POINT	
		UNIT	LOCATION		UNIT	ADJUST
UHF SENSITIVITY	1 <ul style="list-style-type: none"> <li>• Frequency display: 434.90 MHz (except USA) 444.90 MHz (USA)</li> <li>• Set the signal generator; Level : <math>10 \mu V^*</math> (-87 dBm) Dev. : <math>\pm 3.5</math> kHz Mod. : 1 kHz</li> <li>• [SQL] control: Max. CCW</li> <li>• Receiving</li> </ul>	LOGIC	Connect the oscilloscope to CP1.	Maximum	U. COIL	Adjust in sequence L1 L2 L3
VHF SENSITIVITY	1 <ul style="list-style-type: none"> <li>• Frequency display: 146.00 MHz (except EUR, UK) 145.00 MHz (EUR, UK)</li> <li>• Set the signal generator; Level : <math>20 \mu V^*</math> (-81 dBm) Dev. : <math>\pm 3.5</math> kHz Mod. : 1 kHz</li> </ul>	LOGIC	Connect the oscilloscope to CP1.	Maximum	V. COIL	Adjust in sequence L1 L2 L3 L4
S-METER	1 <ul style="list-style-type: none"> <li>• Frequency display: 435.00 MHz (except USA) 445.00 MHz (USA)</li> <li>• Set the signal generator; Level : <math>0.35 \mu V^*</math> (-116 dBm) Dev. : <math>\pm 3.5</math> kHz Mod. : 1 kHz</li> </ul>	FUNCTION DISPLAY	S/R/F indicator	2 dots	DET	R26
	2 <ul style="list-style-type: none"> <li>• Frequency display: 146.00 MHz (except EUR, UK) 145.00 MHz (EUR, UK)</li> <li>• Set the signal generator; Level : <math>0.35 \mu V^*</math> (-116 dBm) Dev. : <math>\pm 3.5</math> kHz Mod. : 1 kHz</li> </ul>					R4

CCW: Counterclockwise

\*This output level of standard signal generator (SSG) is indicated as SSG's open circuit.



■ MAIN UNIT

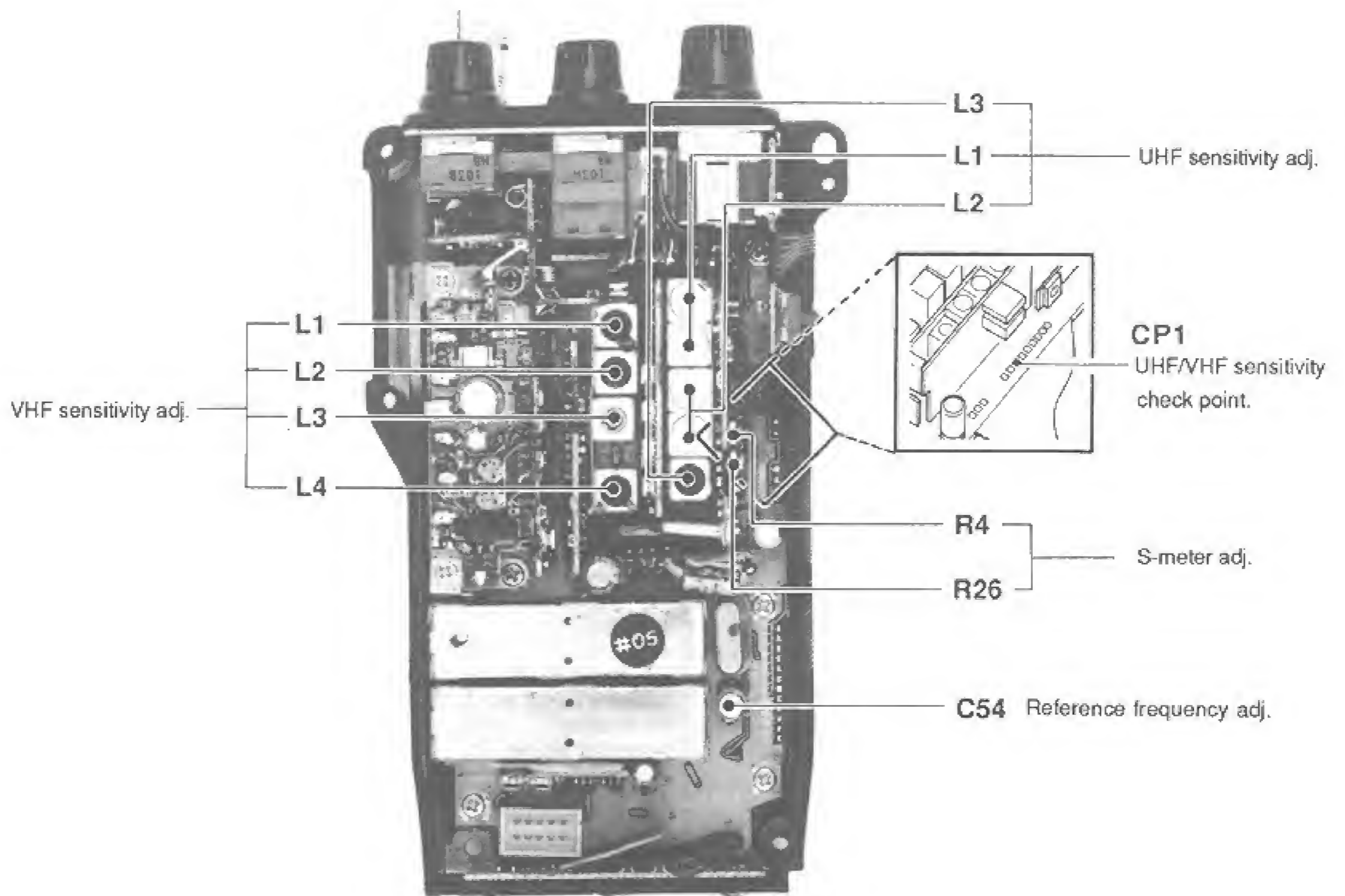

## 6-4 TRANSMITTER ADJUSTMENT

ADJUSTMENT	ADJUSTMENT CONDITIONS	MEASUREMENT		VALUE	ADJUSTMENT POINT	
		UNIT	LOCATION		UNIT	ADJUST
OUTPUT POWER	1 <ul style="list-style-type: none"> <li>• Frequency display: 435.00 MHz (except USA) 445.00 MHz (USA)</li> <li>• Transmitting</li> </ul>	Top panel	Connect the RF power meter to the antenna connector.	5.0 W	YGR	R3
	2 <ul style="list-style-type: none"> <li>• Frequency display: 146.00 MHz (except EUR, UK) 145.00 MHz (EUR, UK)</li> <li>• Transmitting</li> </ul>			5.0 W		R4
DEVIATION	1 <ul style="list-style-type: none"> <li>• Frequency display: 435.00 MHz (except USA) 445.00 MHz (USA)</li> <li>• Apply an AF signal to the [MIC] jack. 95 mV/1 kHz (except USA) 210 mV/1 kHz (USA)</li> <li>• Set the deviation meter. HPF : 50 Hz LPF : 20 kHz De-emphasis : OFF Detector : (P-Py)2</li> </ul>	Top panel	Connect the deviation meter to the antenna connector via the attenuator.	4.8 kHz	MC	R15
	2 <ul style="list-style-type: none"> <li>• Frequency display: 146.00 MHz (except EUR, UK) 145.00 MHz (EUR, UK)</li> </ul>			4.8 kHz		R14
DTMF DEVIATION (EUR, ITA USA, AUS SEA)	1 <ul style="list-style-type: none"> <li>• Frequency display: 445.00 MHz (USA) 435.00 MHz (except USA)</li> <li>• Push and hold the [D] key while transmitting.</li> </ul>	Top panel	Connect the deviation meter to the antenna connector via the attenuator.	±3.5 kHz	LOGIC	R58
TONE CALL DEVIATION (EUR, ITA)	1 <ul style="list-style-type: none"> <li>• Frequency display: 435.00 MHz</li> <li>• Push and hold the [LAMP] switch, then push [PTT] switch.</li> </ul>	Top panel	Connect the deviation meter to the antenna connector via the attenuator.	±3.5 kHz	LOGIC	R60

## ■ MAIN UNIT

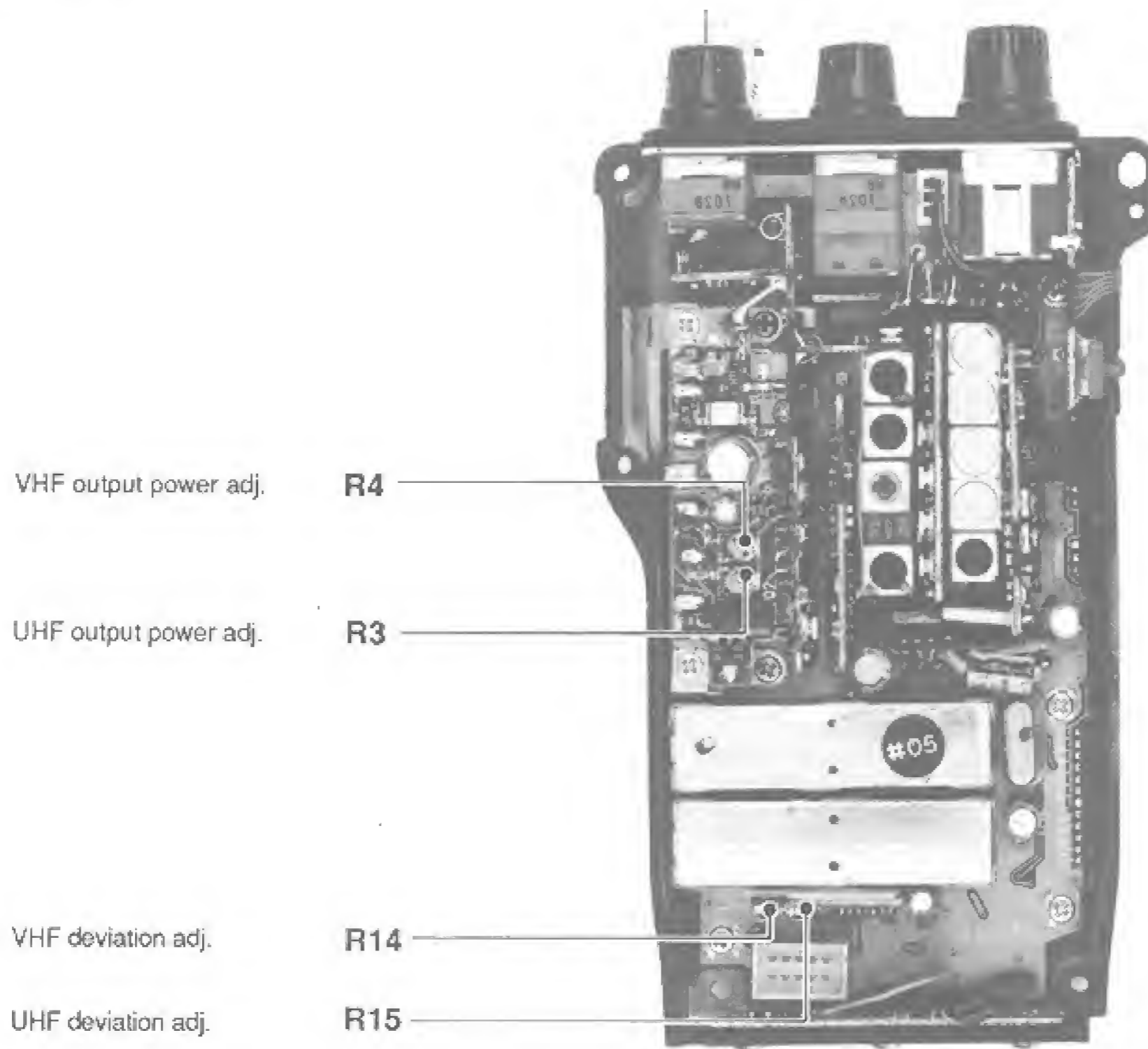

## ■ LOGIC UNIT

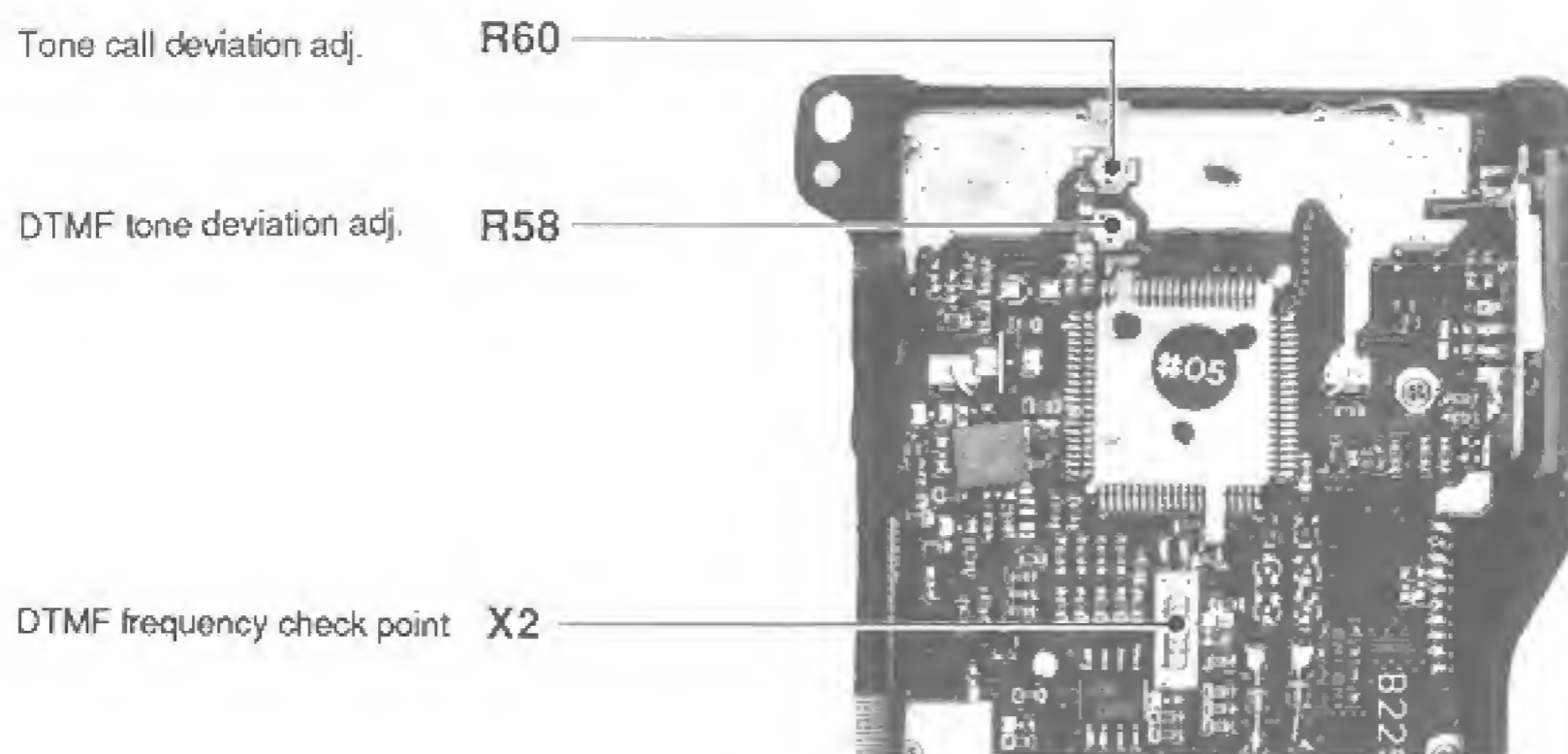

# SECTION 7 BOARD LAYOUTS

## 7-1 KEYBOARD AND PTT UNIT

### ■ KEYBOARD

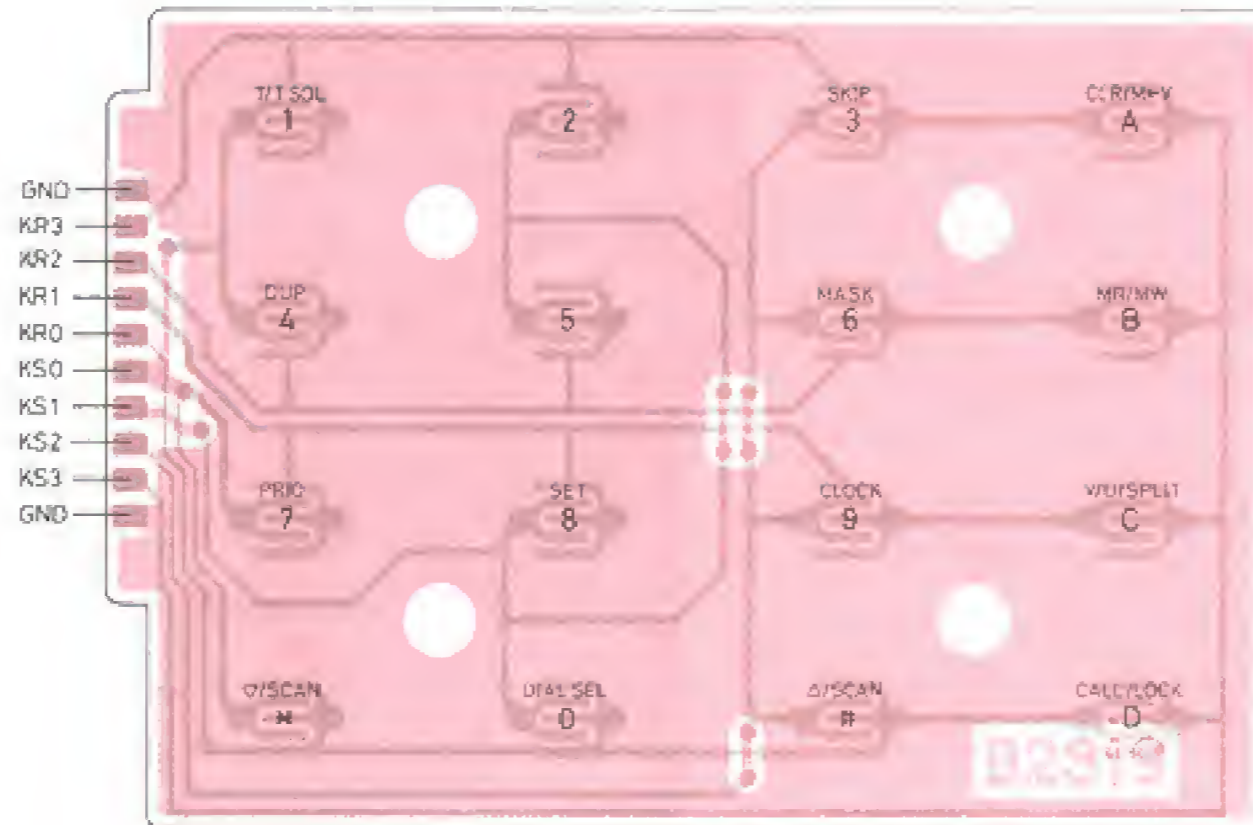

### ■ PTT UNIT

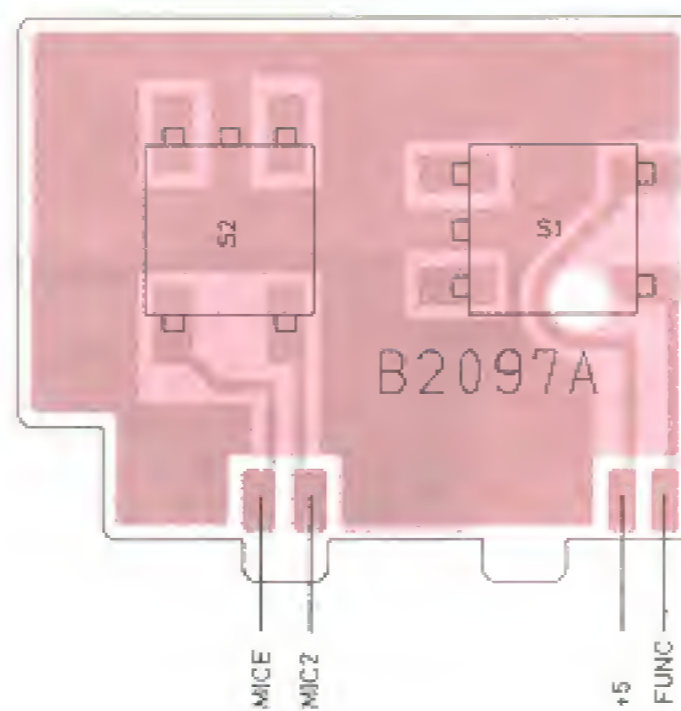



# 7-2 LOGIC UNIT

(Top View)

The combination of this page and the next page show the unit layout in the same configuration as the actual P.C. Board.

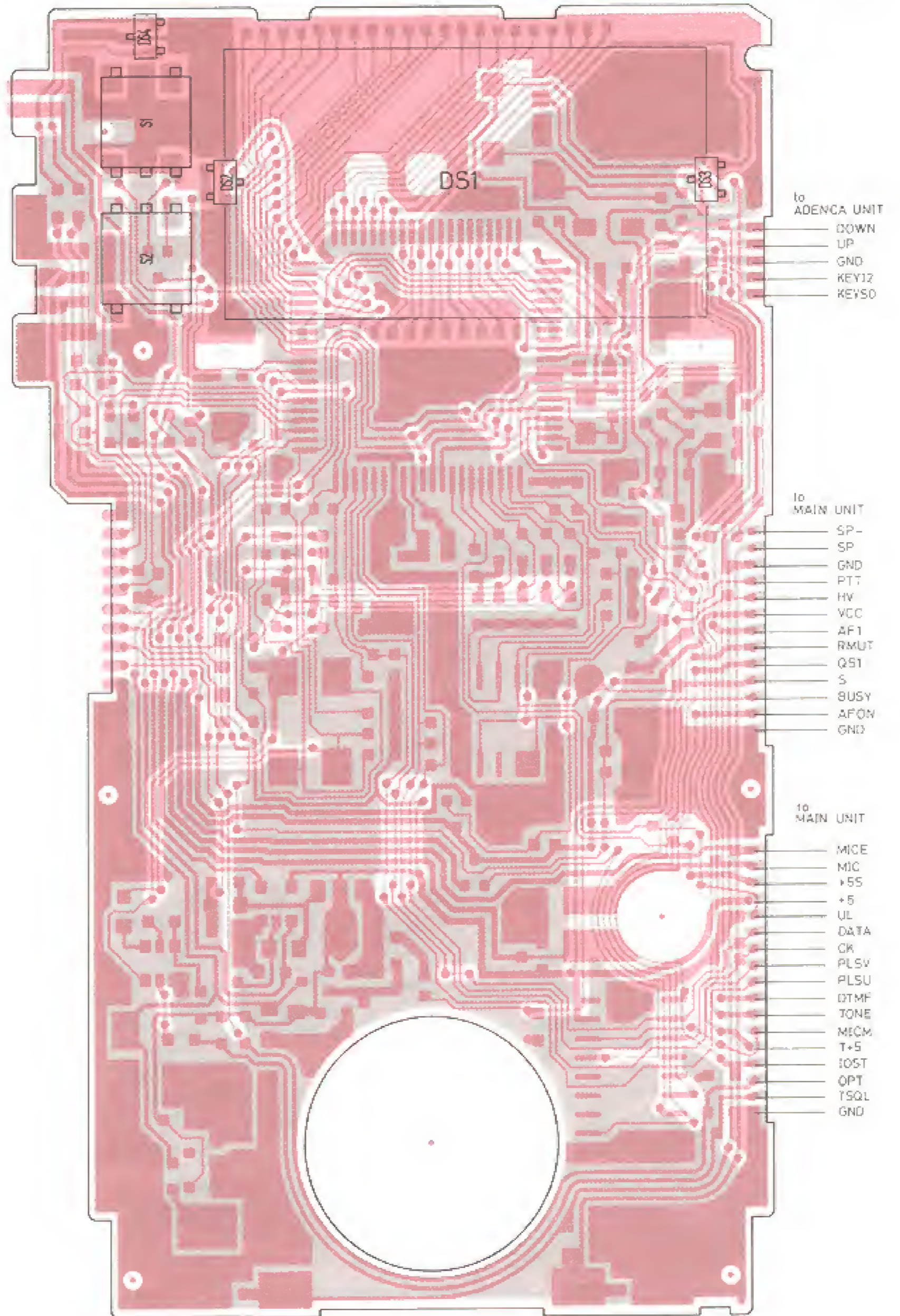



(Bottom View)

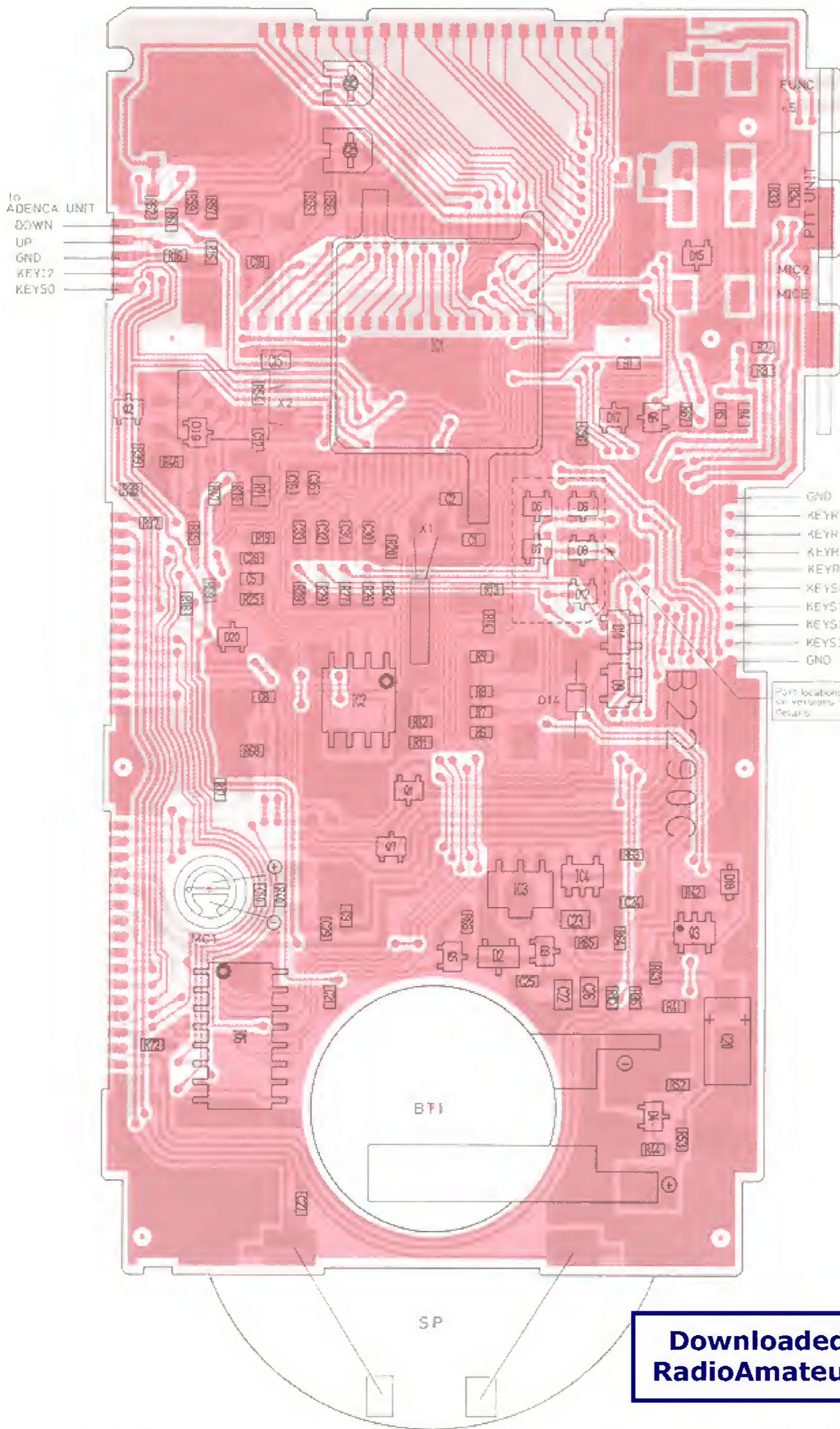

TC4S81F  
IC4



RH5VA37CA-T1  
IC3

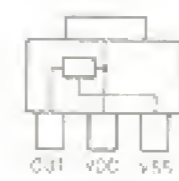

2SC4081 R  
Q1, Q2, Q6, Q7



Symbol: BR

1MD6  
Q3

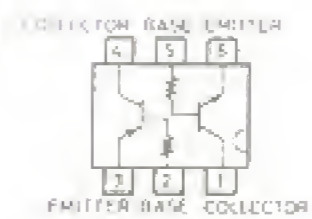

Symbol: D6

2SK880-Y  
Q5



Symbol: XY

1SS322  
D20

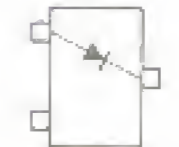

Symbol: A9

DA114  
D5(AUS),  
D8(EUR, UK, USA, AUS)



Symbol: AV

DA204U  
D4, D7(ITA), D12(ITA), D19



Symbol: K

DAN202U  
D3, D5(SEA), D15, D17

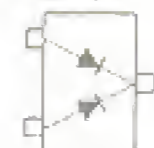

Symbol: N

DWA010  
D9, D10

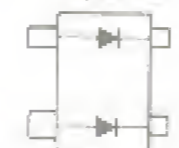

Symbol: W8

02CZ5.1-Z  
D2



Symbol: 5,1Z

DA115  
D5(EUR, UK, USA),  
D6(ITA, USA, AUS, SEA)

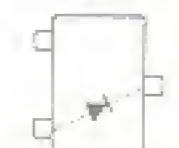

Symbol: AU



### 7-3 INITIAL MATRICES

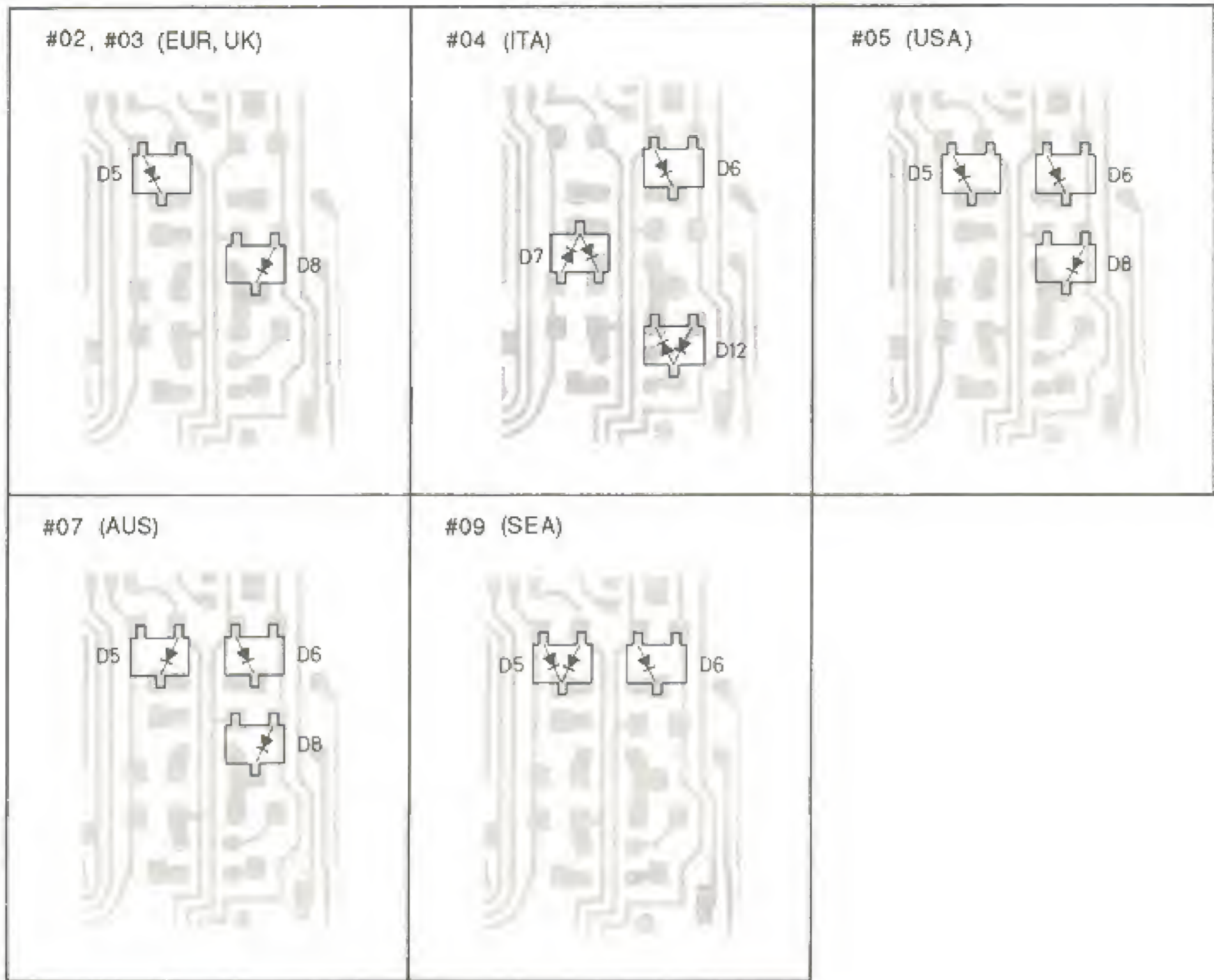

### 7-4 ADENCA UNIT

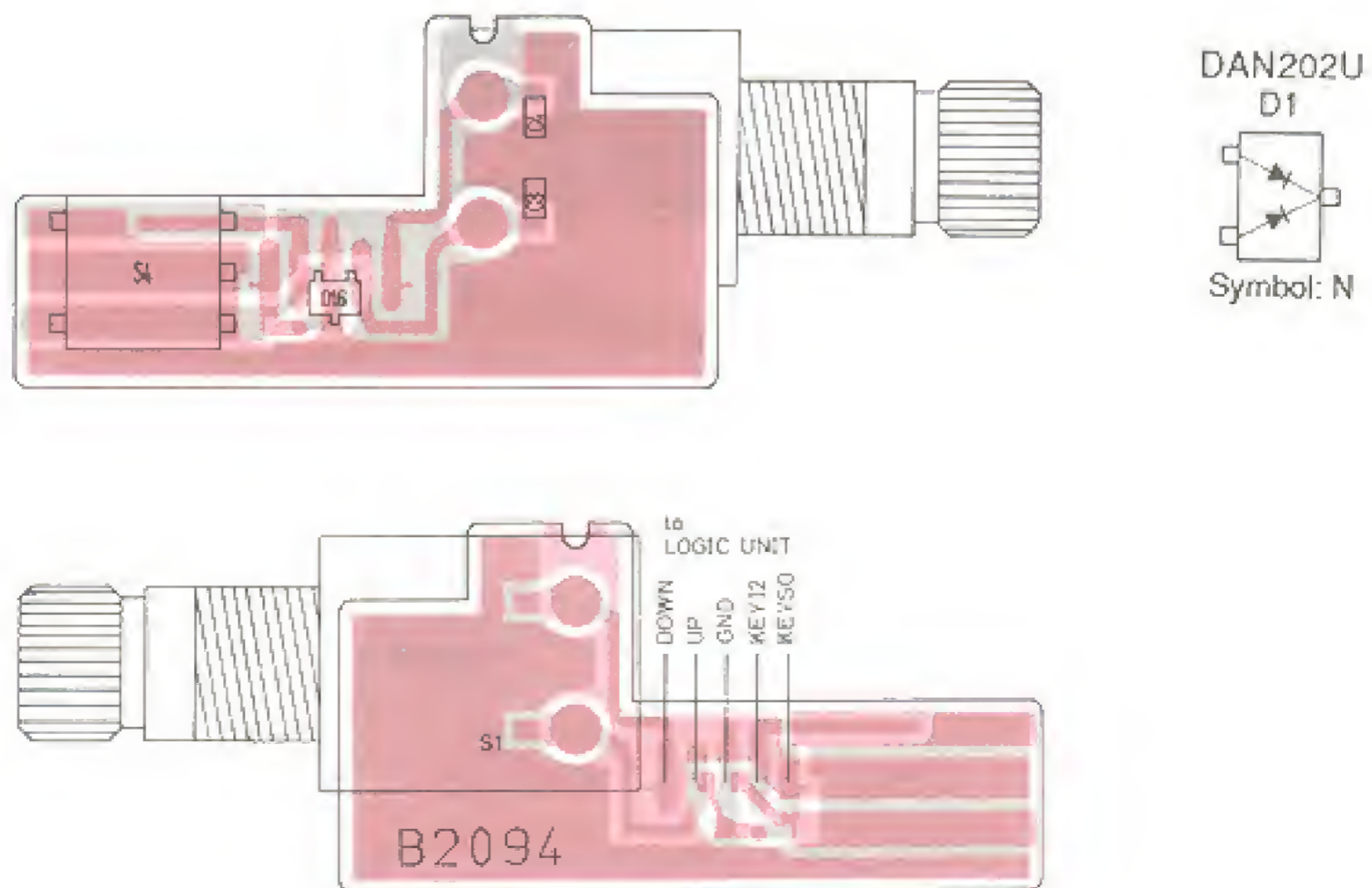

## 7-5 VR, UHF SW AND PRT UNITS

### ■ VR UNIT

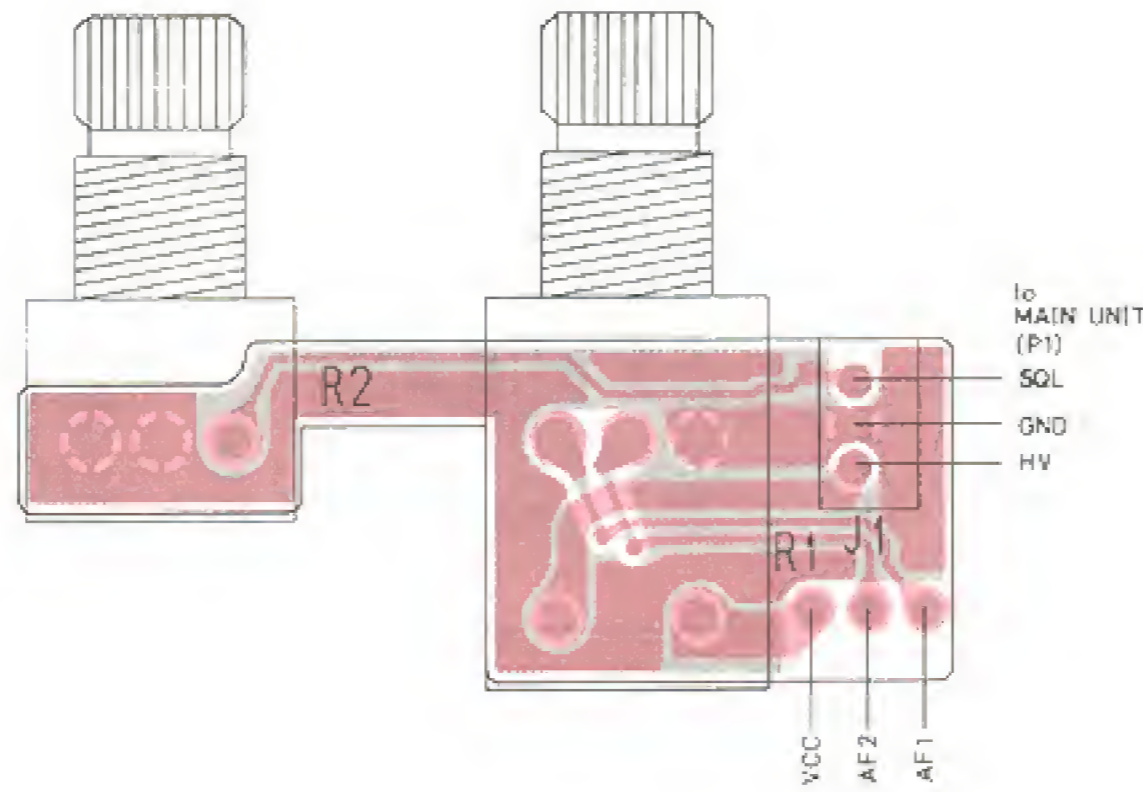

### ■ UHF SW UNIT

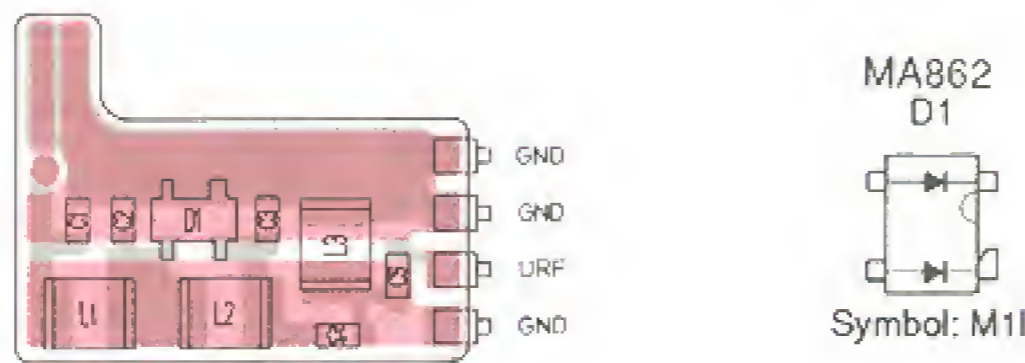

### ■ PRT UNIT

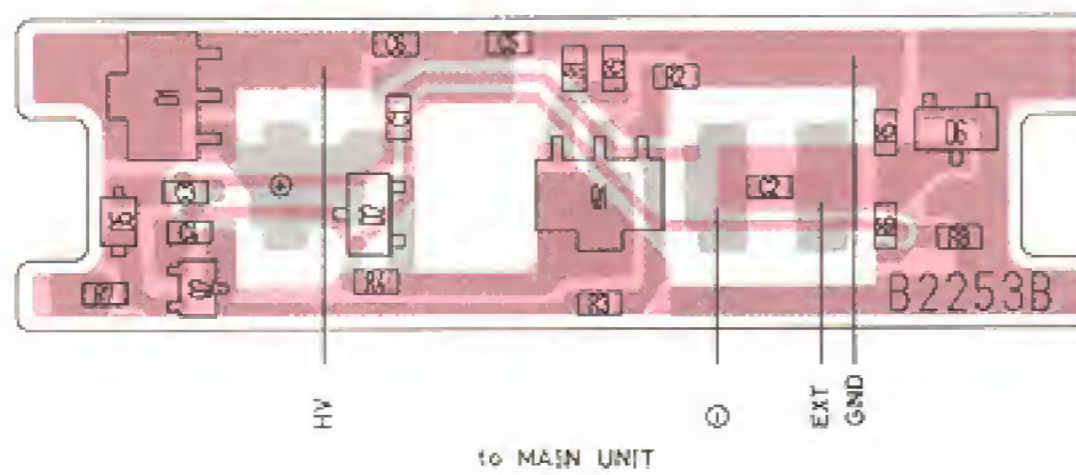



# 7-6 MAIN UNIT

(Top View)

The combination of this page and the next page show the unit layout in the same configuration as the actual P.C. Board.

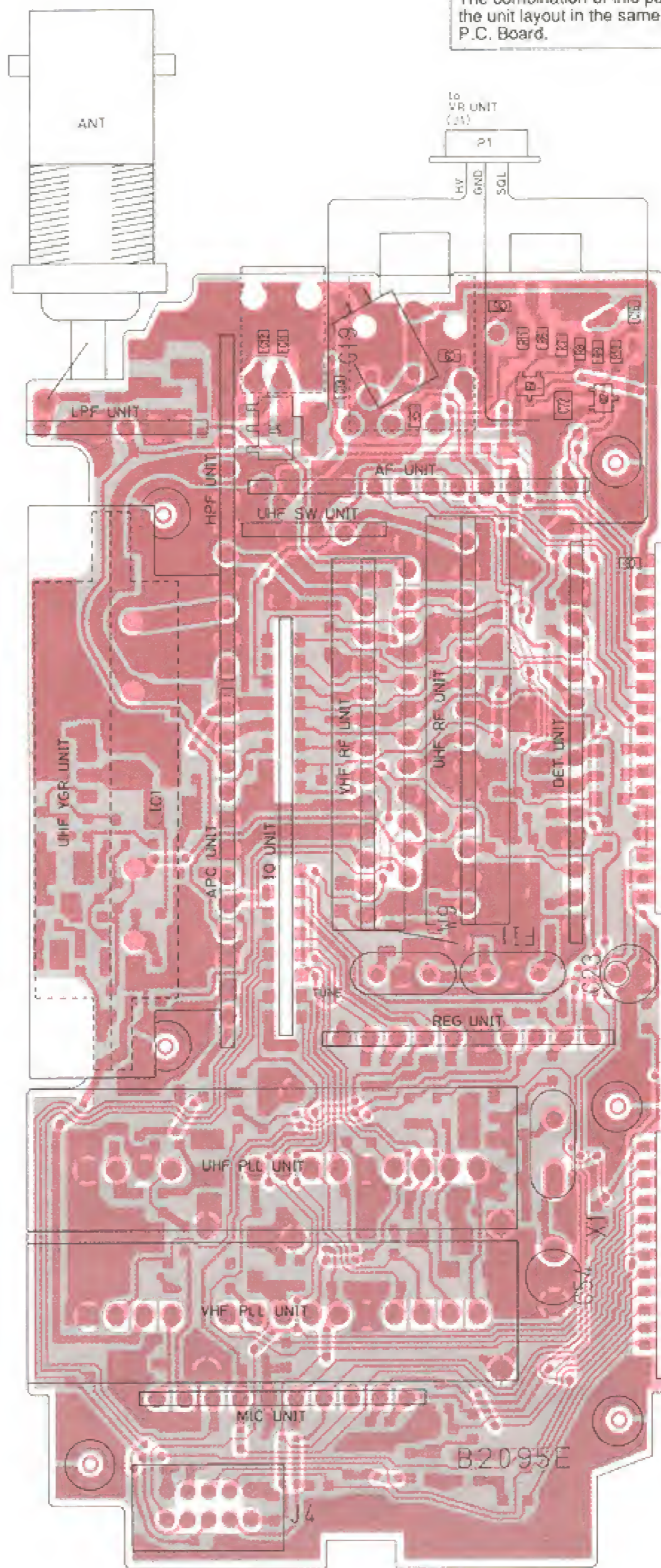
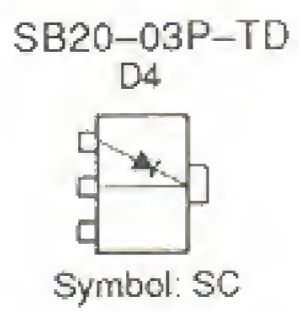
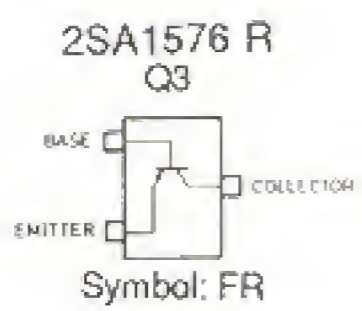



(Bottom View)

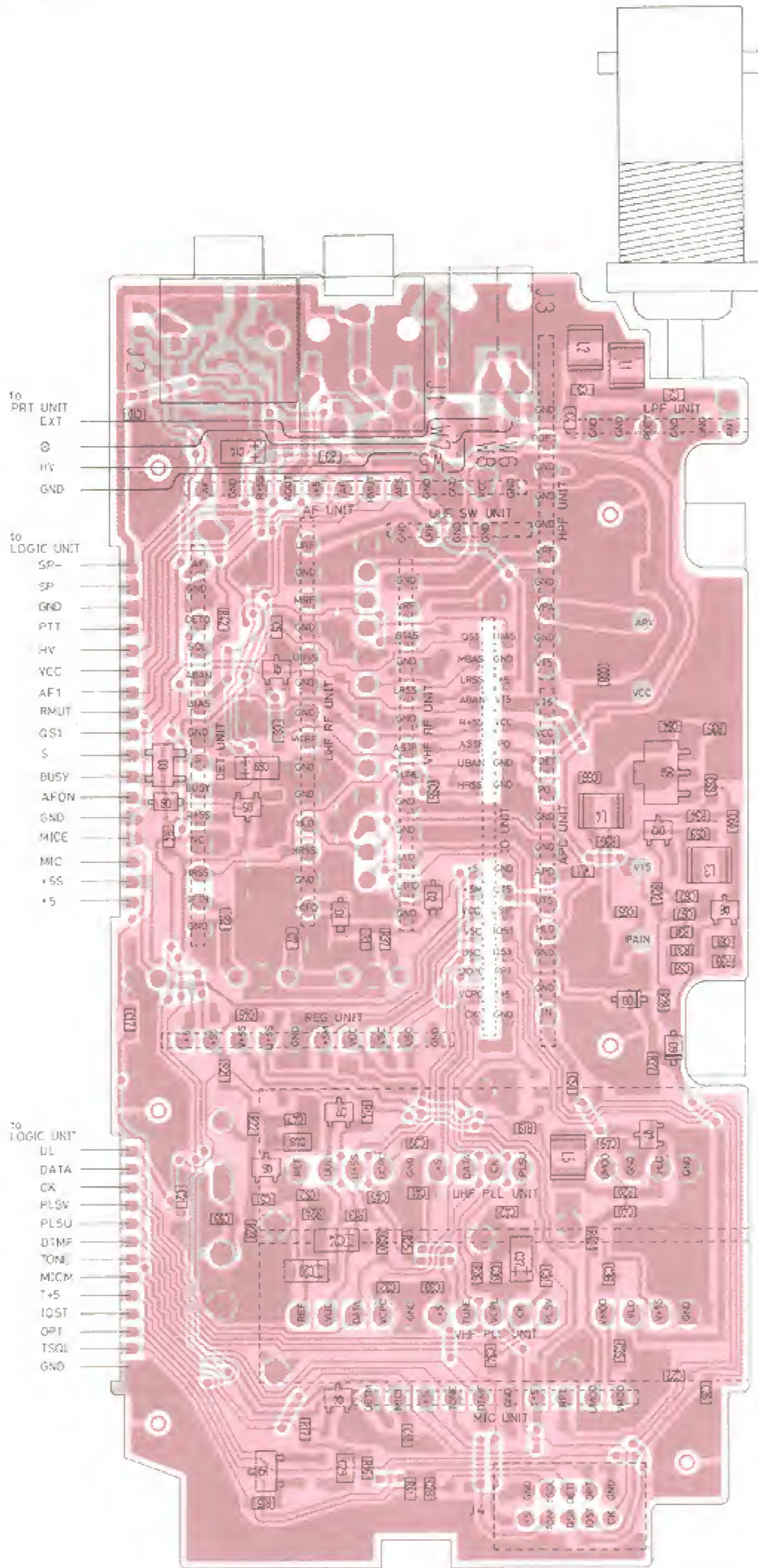

2SA1162-GR  
Q5

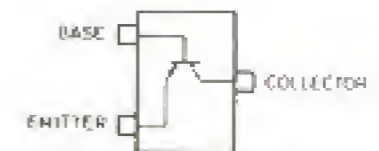

Symbol: SG

2SC2954-T2B  
Q9



Symbol: QK

2SC4081 S  
Q6



Symbol: BS

2SC4403-3  
Q7, Q8



Symbol: LY3

DTA144TU  
Q1



Symbol: 96

DTC144EU  
Q2, Q4

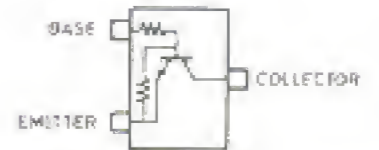

Symbol: 26

DA204U  
D12

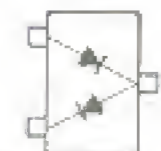

Symbol: K

DAN202U  
D7

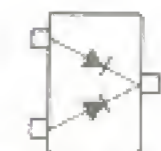

Symbol: N

DWA010  
D3

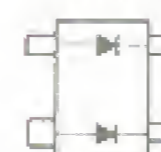

Symbol: W8

DAP202U  
D5

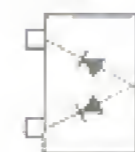

Symbol: P



# 7-7 AF, MIC AND REG UNITS

## ■ AF UNIT

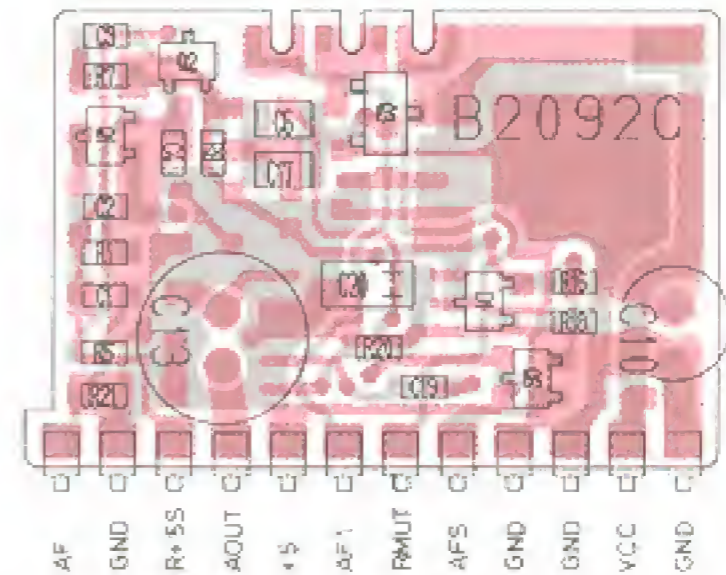
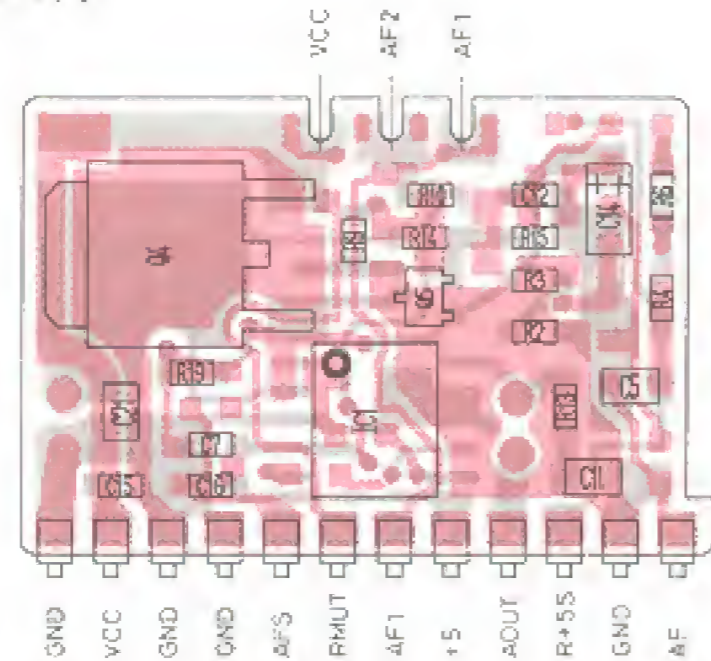

2SB1182 Q  
Q4

2SC4081 R  
Q1, Q2, Q5, Q6

2SJ106-GR  
Q3

DAP202U  
D1

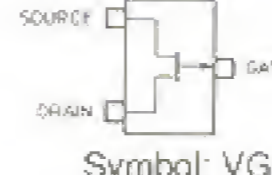
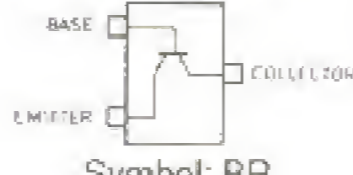
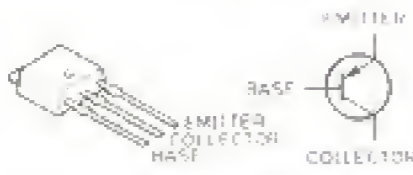

Symbol: BR

Symbol: VG

Symbol: P

## ■ MIC UNIT

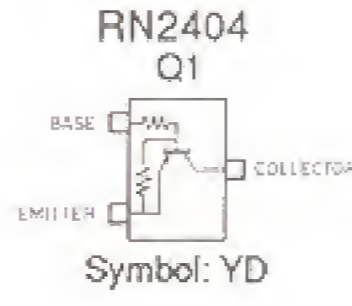
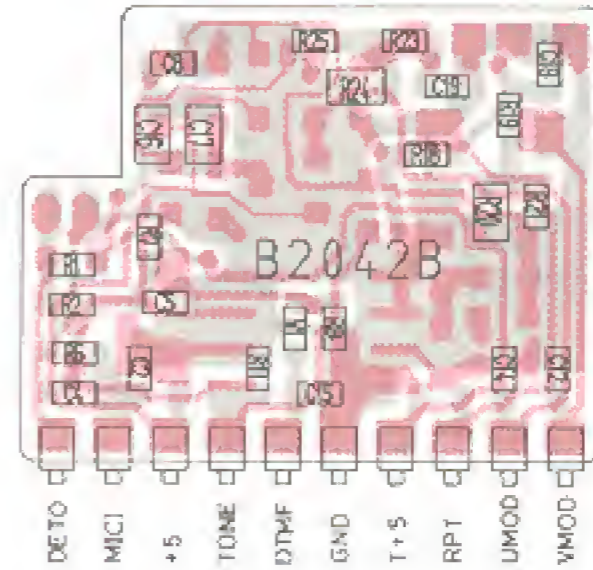
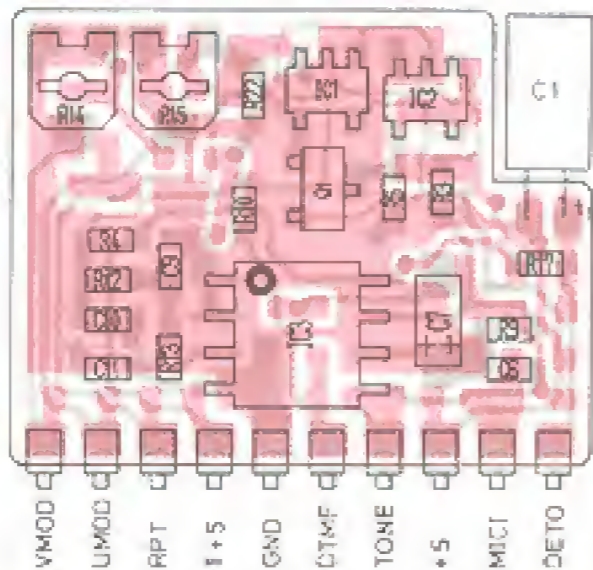

TC4S66F  
IC1, IC2

RN2404  
Q1

Symbol: YD

## ■ REG UNIT

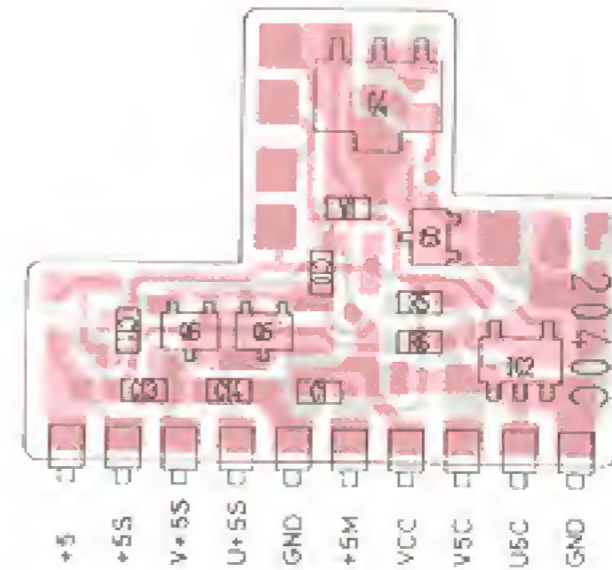
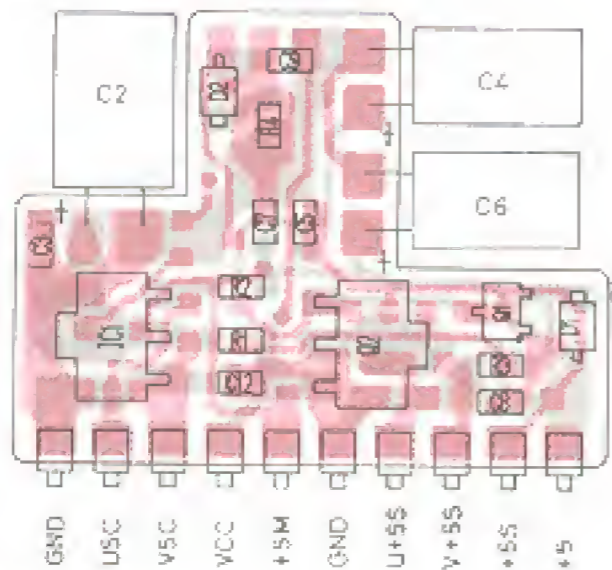

S-81250HG-RD-T1  
IC1

TC4S11F  
IC2

2SA1588-GR  
Q5, Q6

2SB798 DK  
Q2, Q4

2SC4081 S  
Q1, Q3

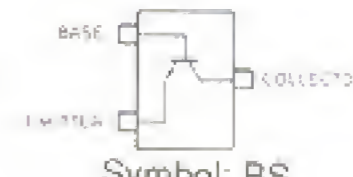
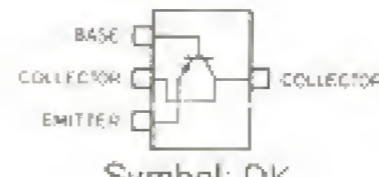
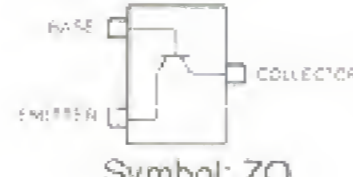
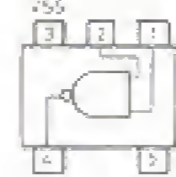
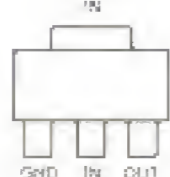

Symbol: ZO

Symbol: DK

Symbol: BS



## 7-8 APC AND IO UNITS

### ■ APC UNIT

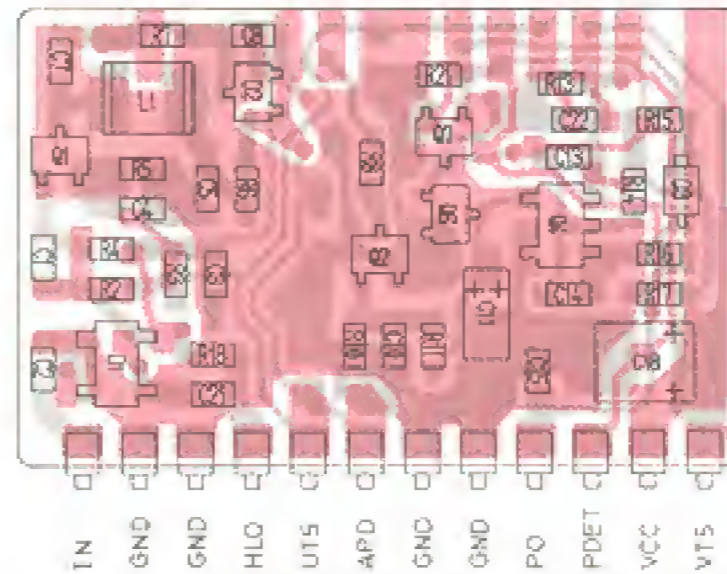
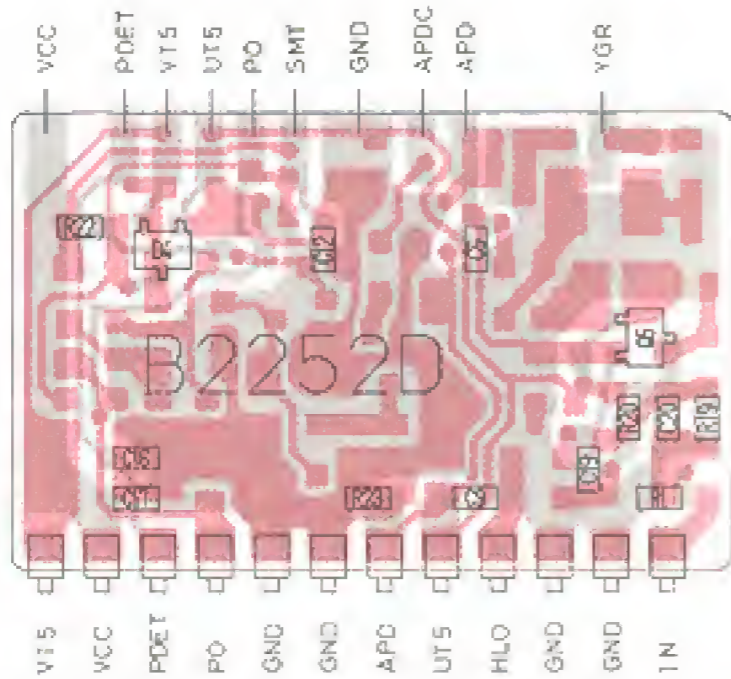

2SC4081 S

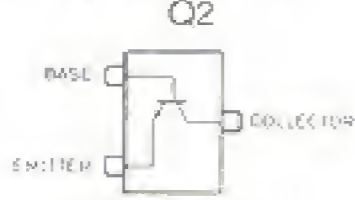

Symbol: BS

2SC4403-3

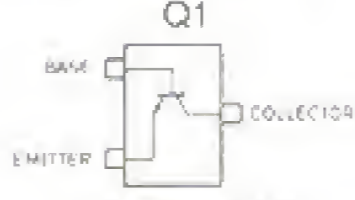

Symbol: LY3

DTA144TU

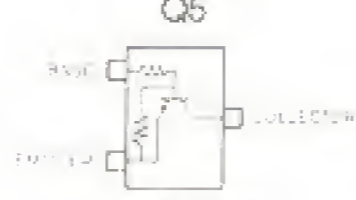

Symbol: 96

DTC144TU

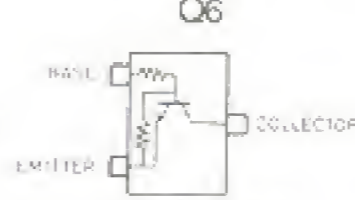

Symbol: 06

DTC144WU

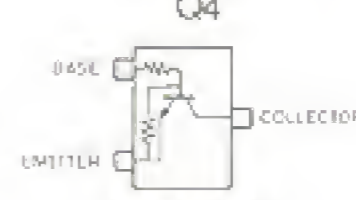

Symbol: 86

FMS1

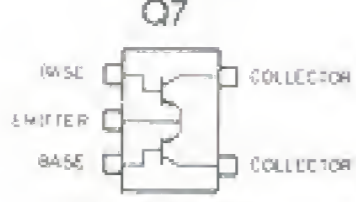

Symbol: S1

MA862

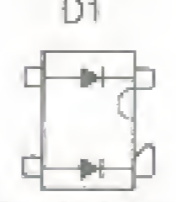

Symbol: M11

DAN202U

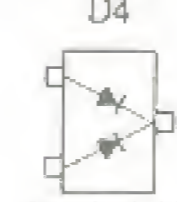

Symbol: N

DA204U

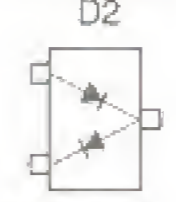

Symbol: K

### ■ IO UNIT

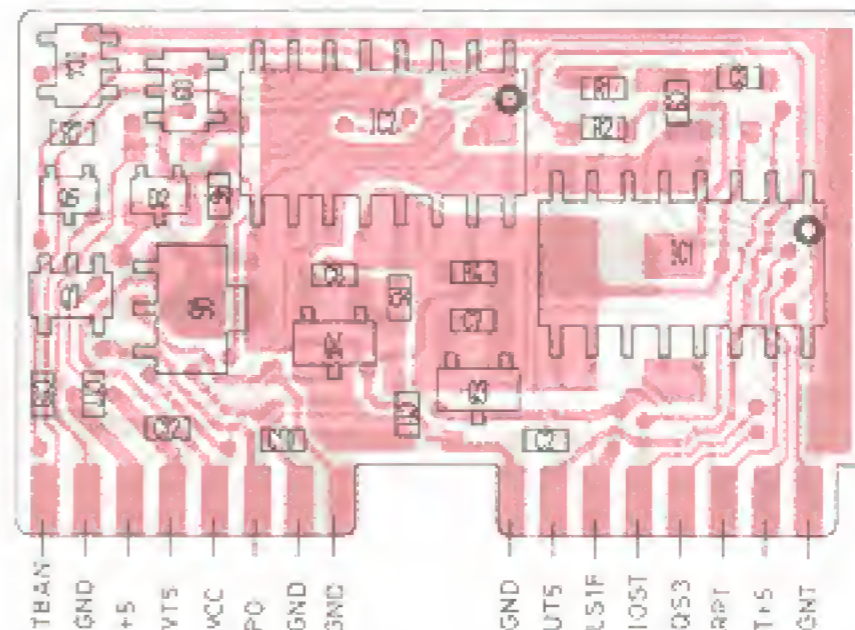
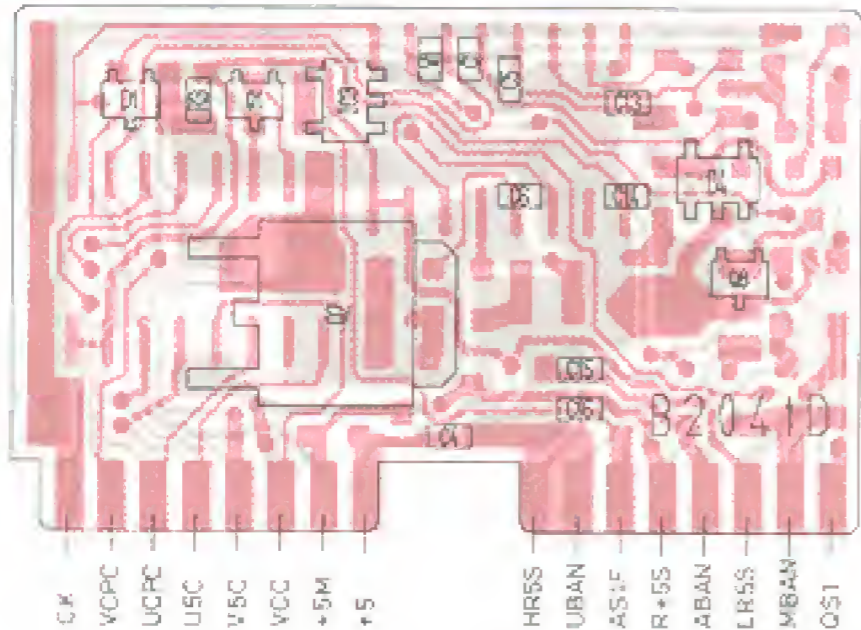

TC4S11F

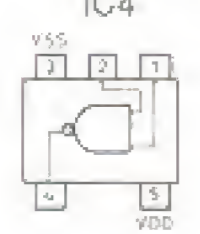

TC4S81F

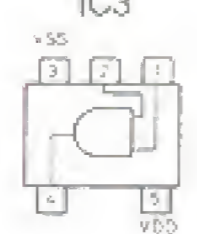

2SA1362-GR

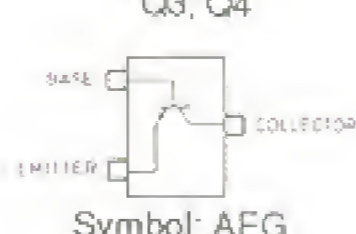

Symbol: AEG

2SB1182 Q



2SB798 DK

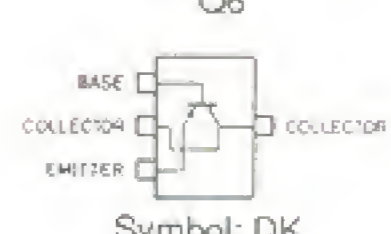

Symbol: DK

2SC4081 S

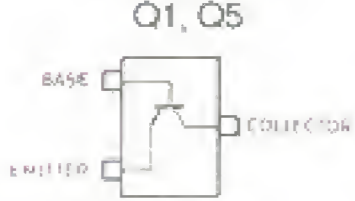

Symbol: BS

DTA144EU

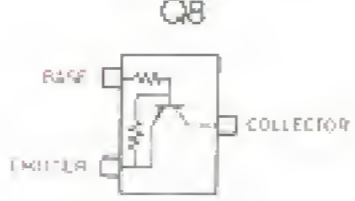

Symbol: 16

FMA4

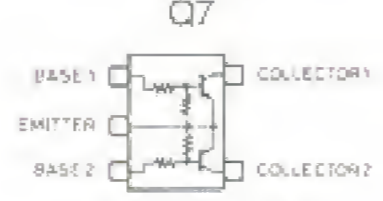

Symbol: A4

1SS308

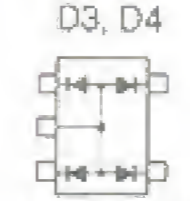

Symbol: A1

DAP202U

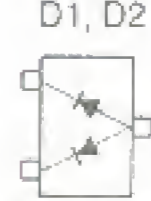

Symbol: P



# 7-9 DET AND UHF YGR UNITS

## ■ DET UNIT

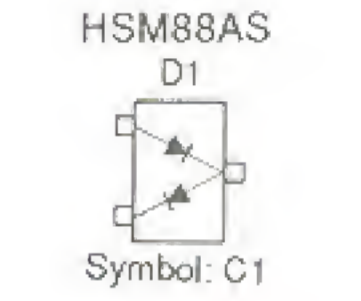
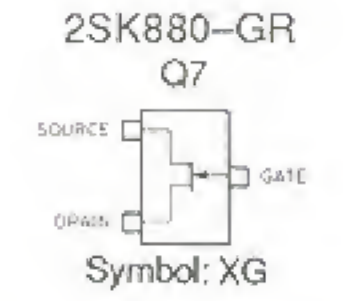
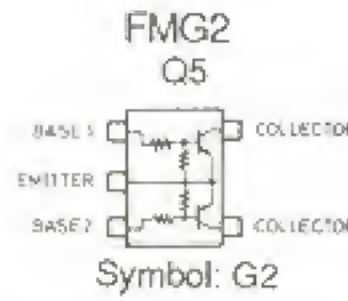
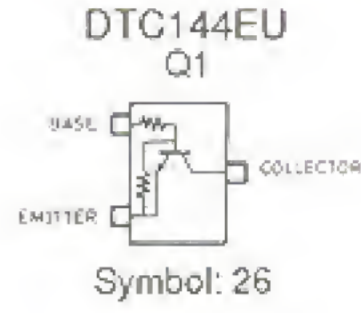
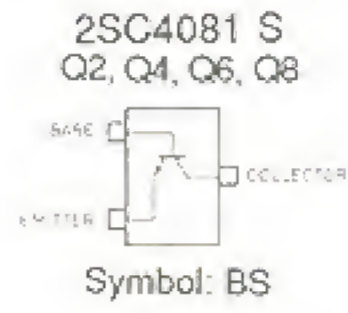
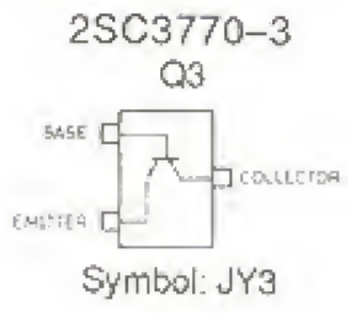
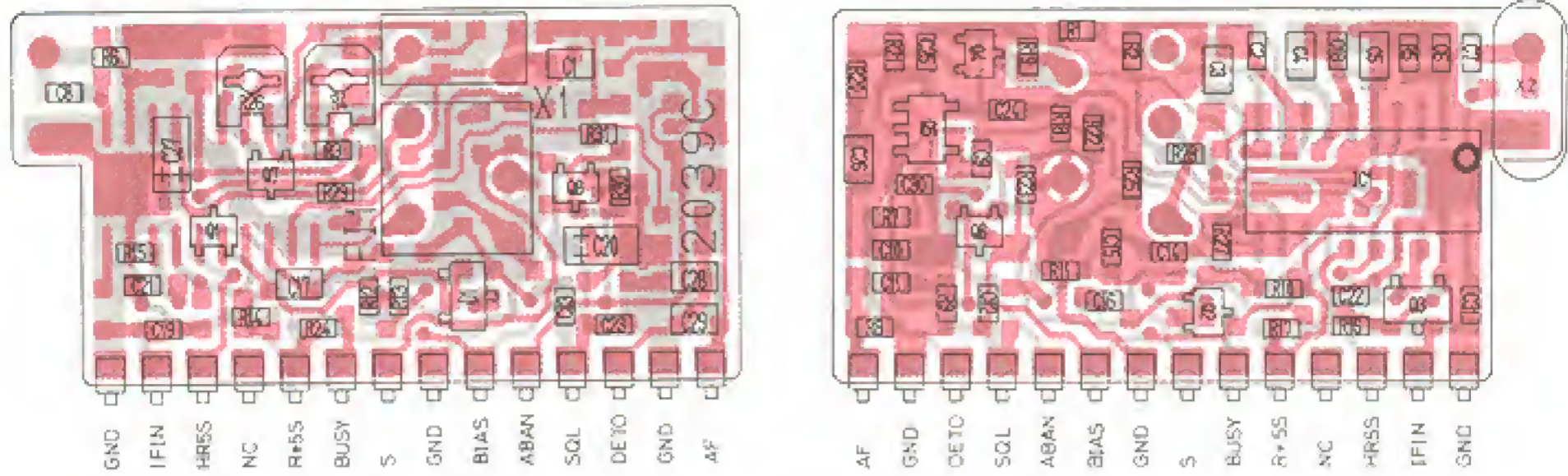

## ■ UHF YGR UNIT

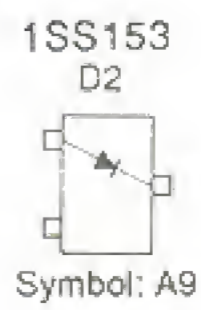
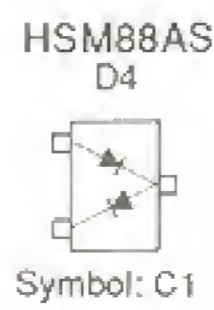
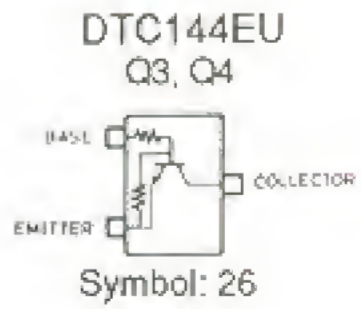
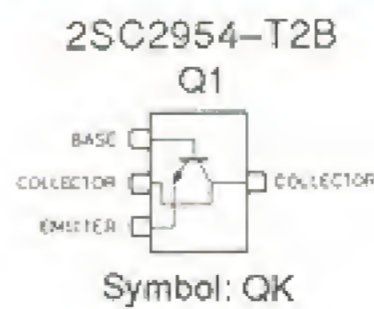
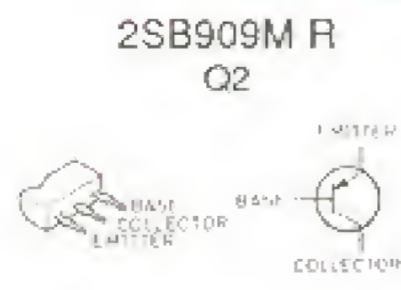
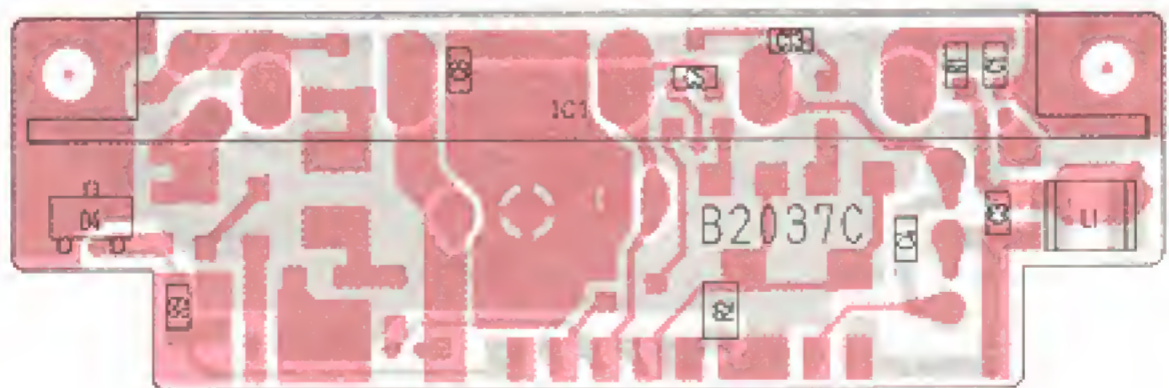
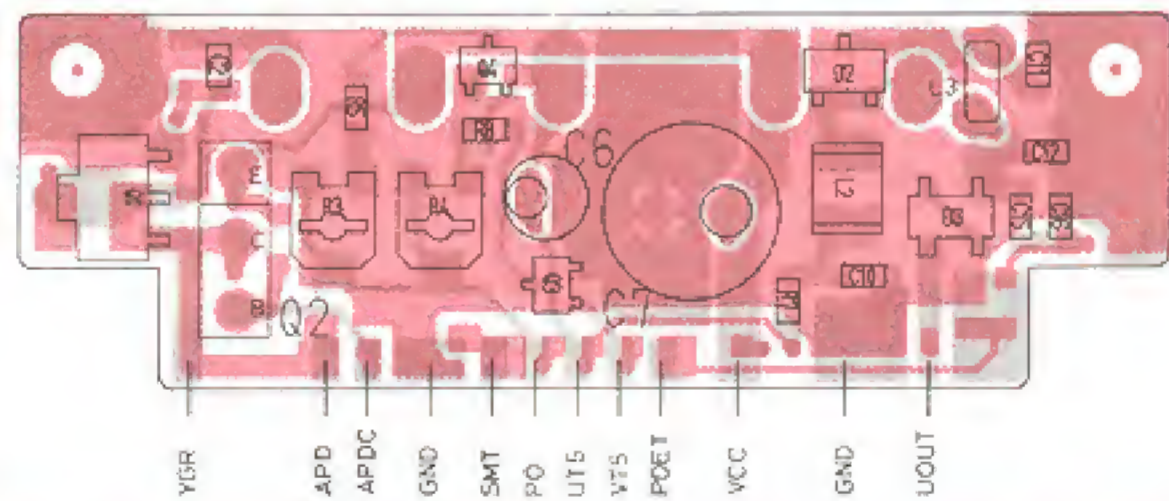



## 7-10 VHF RF, VHF COL, UHF RF AND UHF COL UNITS

### ■ VHF RF UNIT

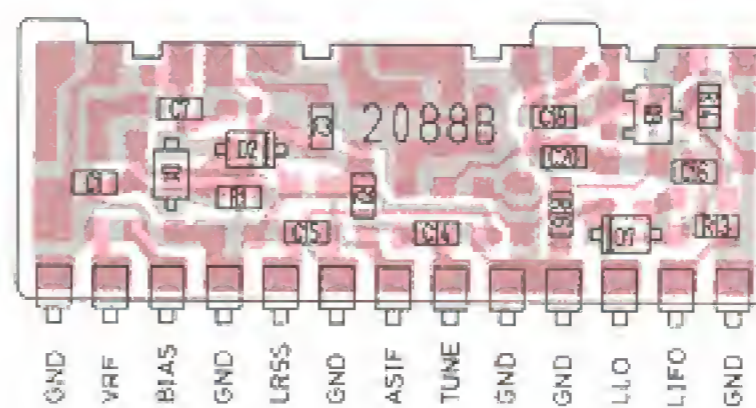
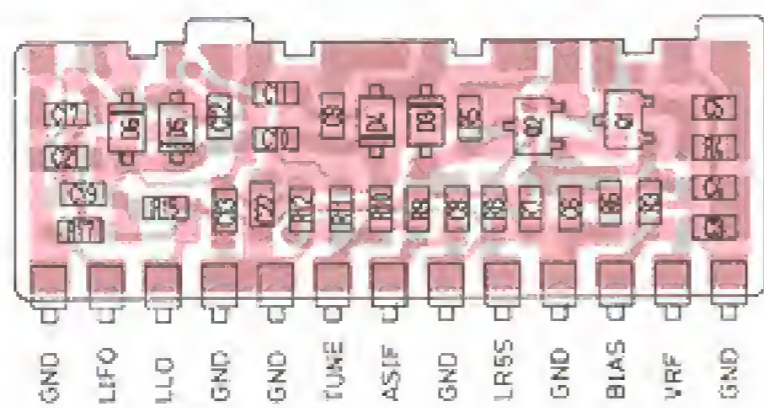

2SC4405-3-TR  
Q1, Q2

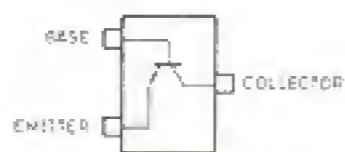

Symbol: OY3

2SK882-Y  
Q3

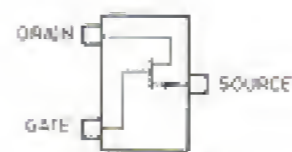

Symbol: TY

### ■ VHF COL UNIT

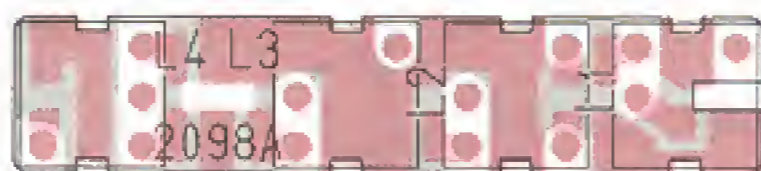

### ■ UHF RF UNIT

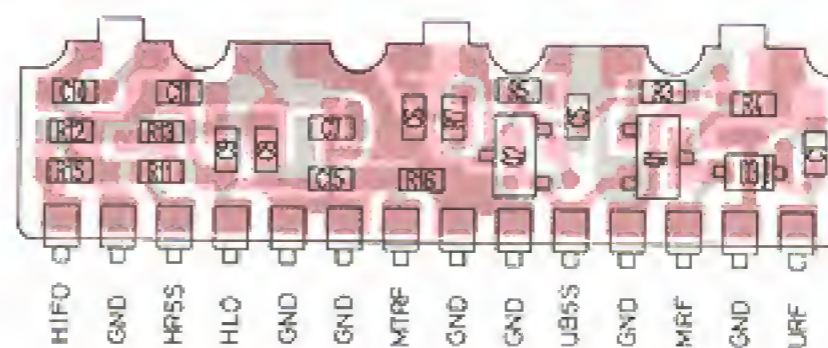
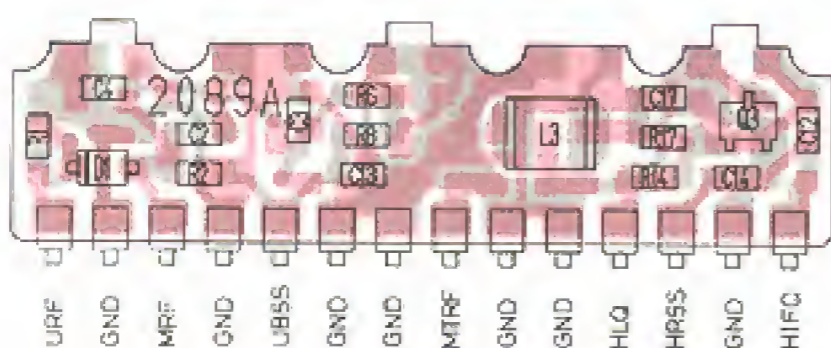

2SC3583 R34  
Q1, Q2

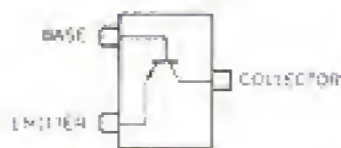

Symbol: R34

2SC4403-3  
Q3

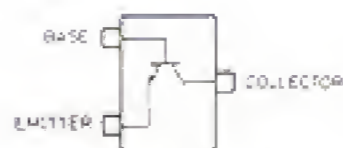

Symbol: LY3

### ■ UHF COL UNIT





## 7-11 VHF PLL, UHF PLL AND UHF VCO UNITS

### ■ VHF PLL UNIT

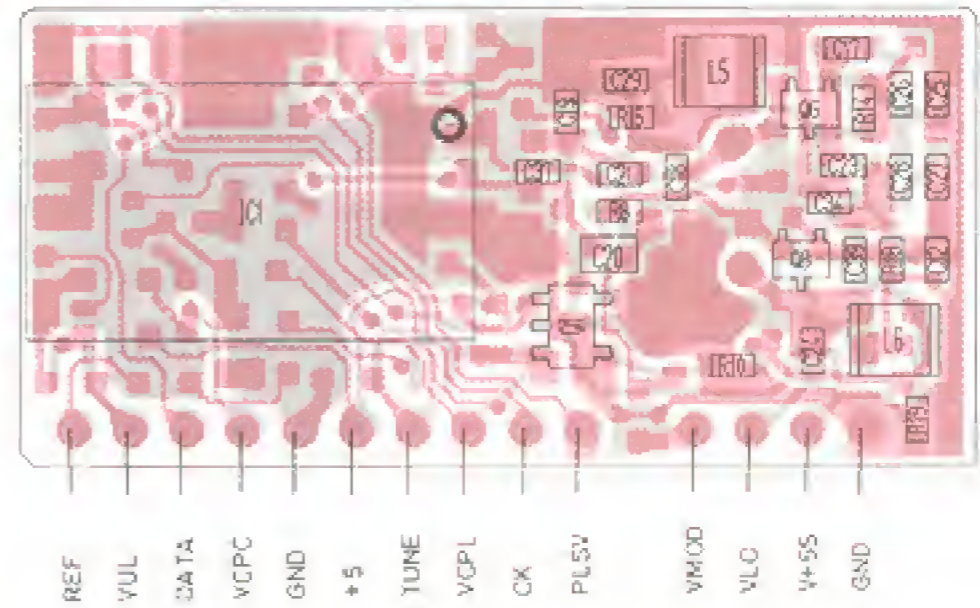
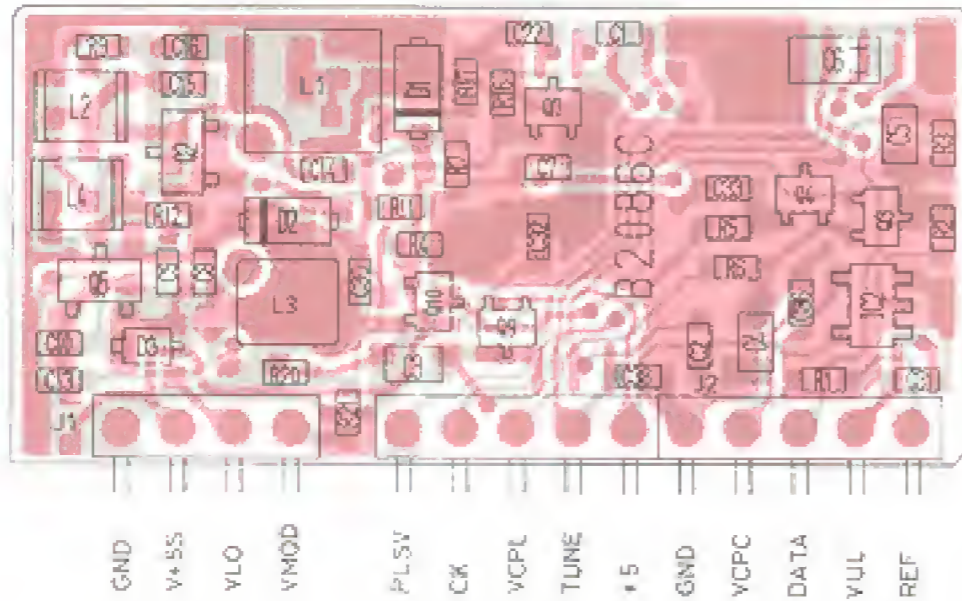

TC4S66F  
IC2



2SC4403-3  
Q6, Q7, Q8

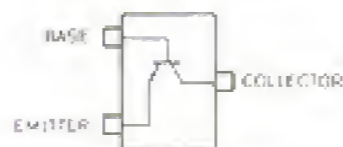

Symbol: LY3

FMA2  
Q1

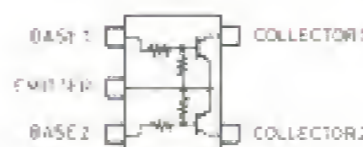

Symbol: A2

2SK210-Y  
Q2

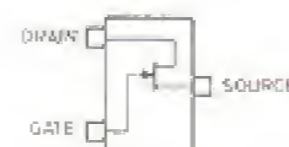

Symbol: YY

2SK302-GR  
Q5



Symbol: TG

2SK880-Y  
Q3, Q4



Symbol: XY

DTA143ZU  
Q9

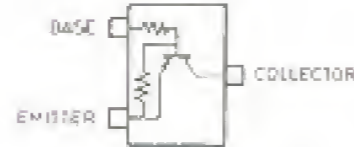

Symbol: 113

DTC144EU  
Q10



Symbol: 26

### ■ UHF PLL UNIT

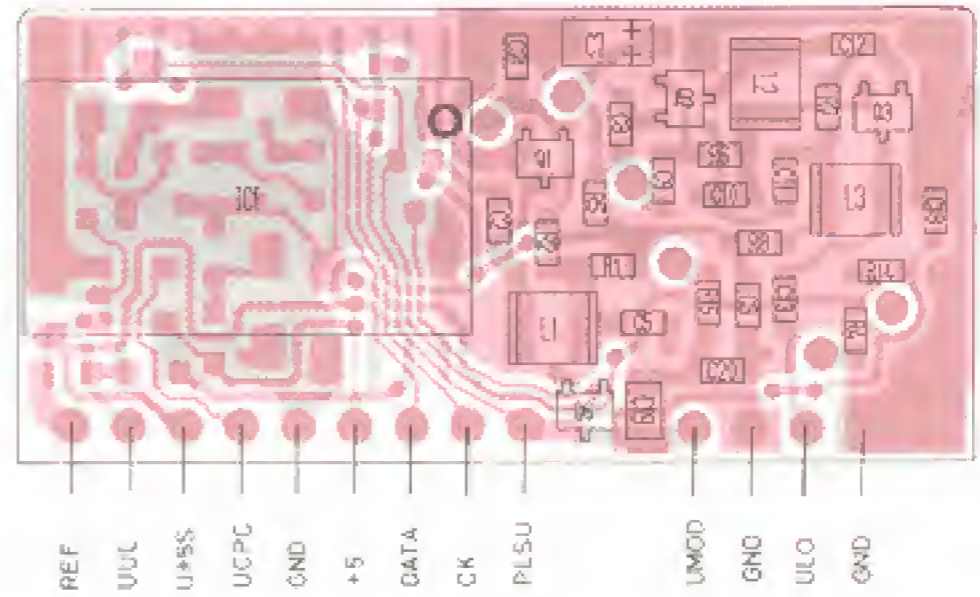
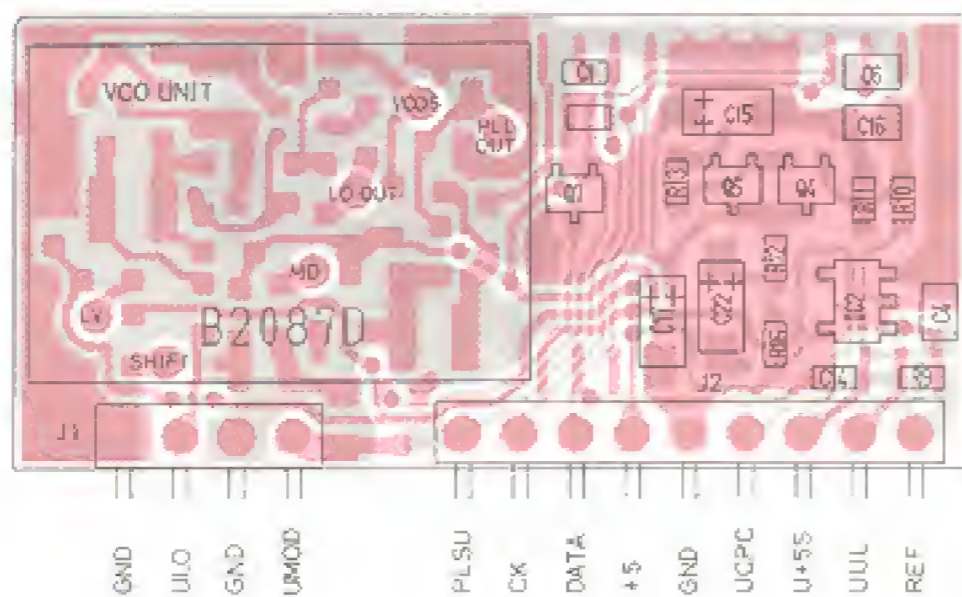

TC4S66F  
IC2

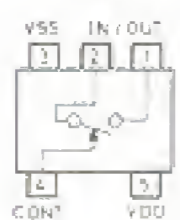

2SC4081 S  
Q4, Q5



Symbol: BS

2SC4403-3  
Q1, Q2, Q3



Symbol: LY3

DTA144EU  
Q7



Symbol: 16

DTC114EU  
Q6

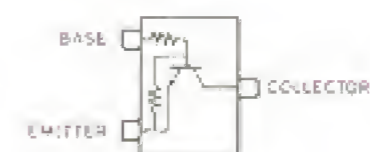

Symbol: 24

### ■ UHF VCO UNIT



2SC3356 R25  
Q1

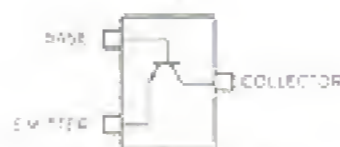

Symbol: R25



## 7-12 LPF AND HPF UNITS

### ■ LPF UNIT

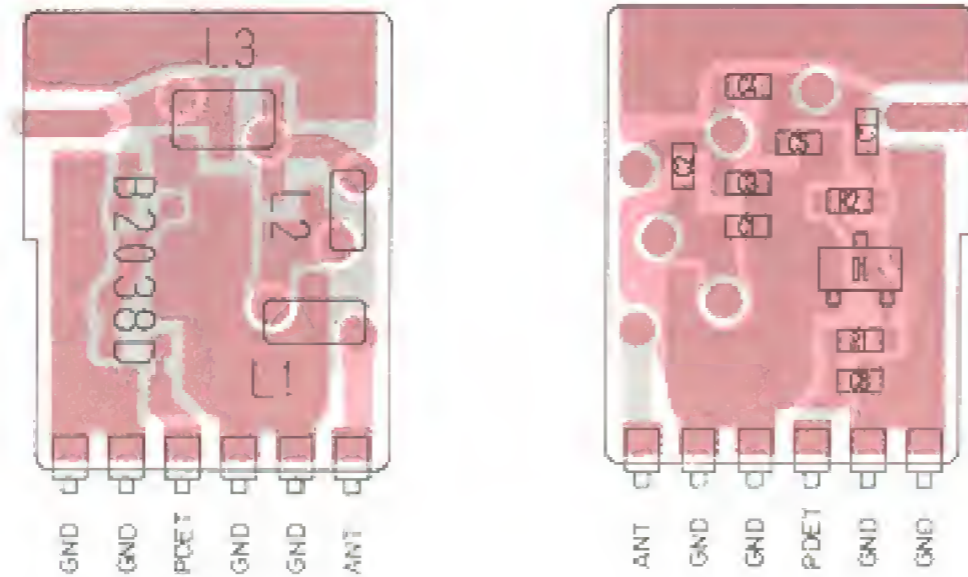

HSM88AS

D1

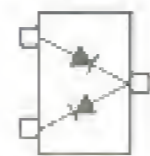

Symbol: C1

### ■ HPF UNIT

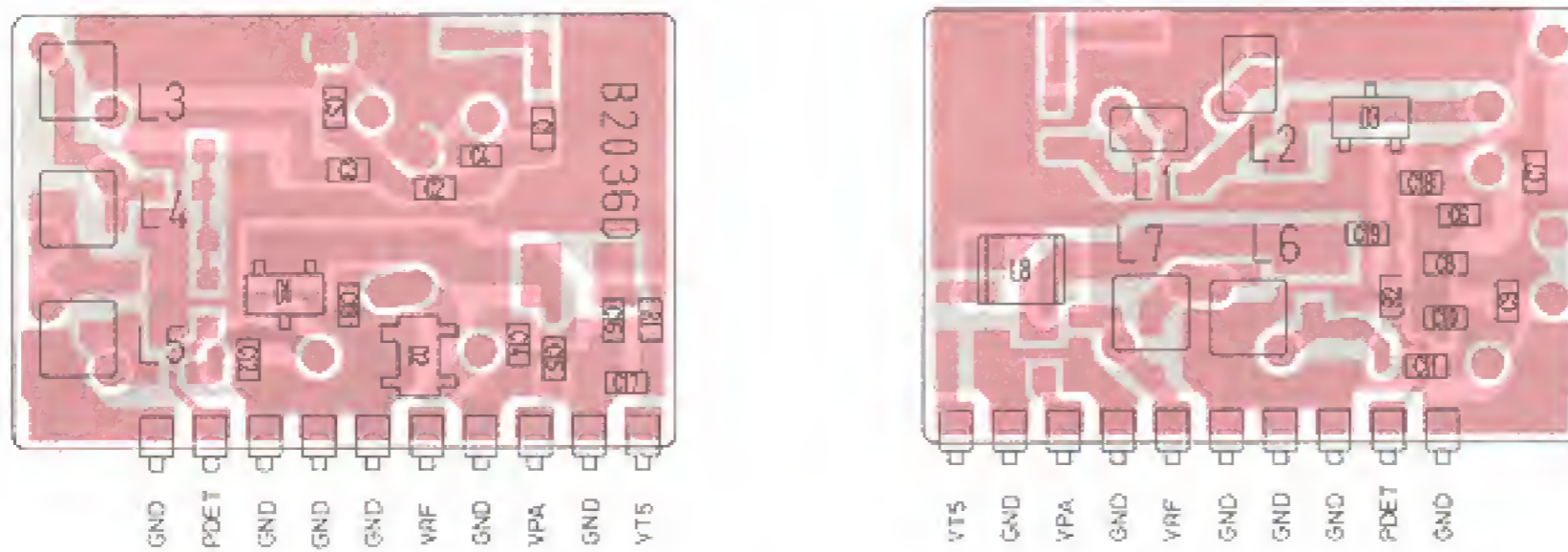

1SS153

D1

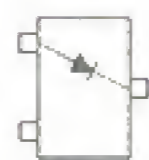

Symbol: A9

HSM88AS

D3

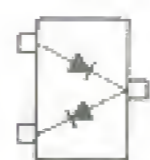

Symbol: C1

MA862

D2

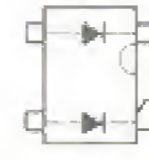

Symbol: M11

Downloaded by  
RadioAmateur.EU



# SECTION 8 BLOCK DIAGRAM

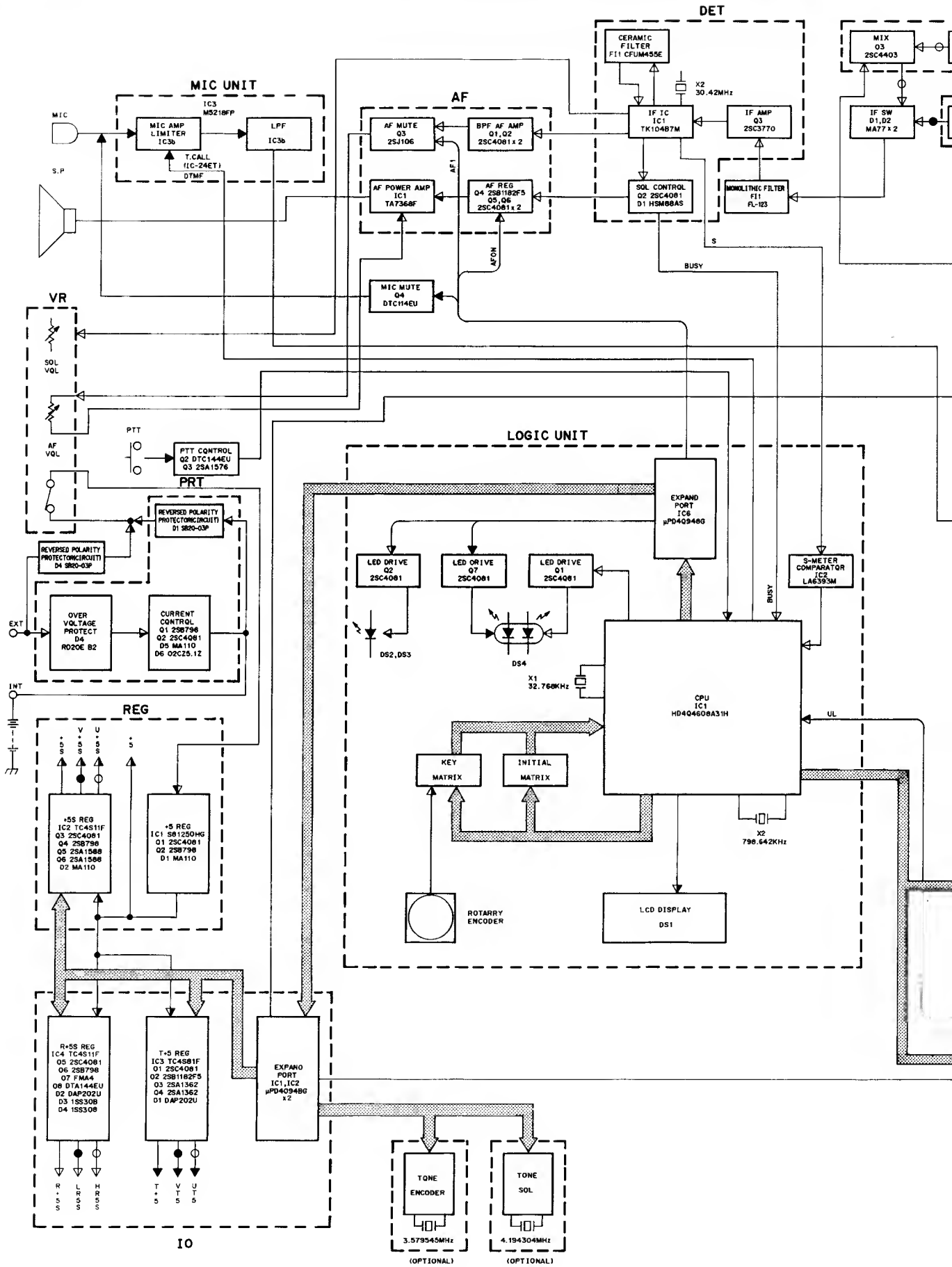

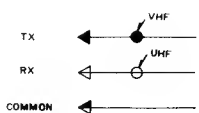
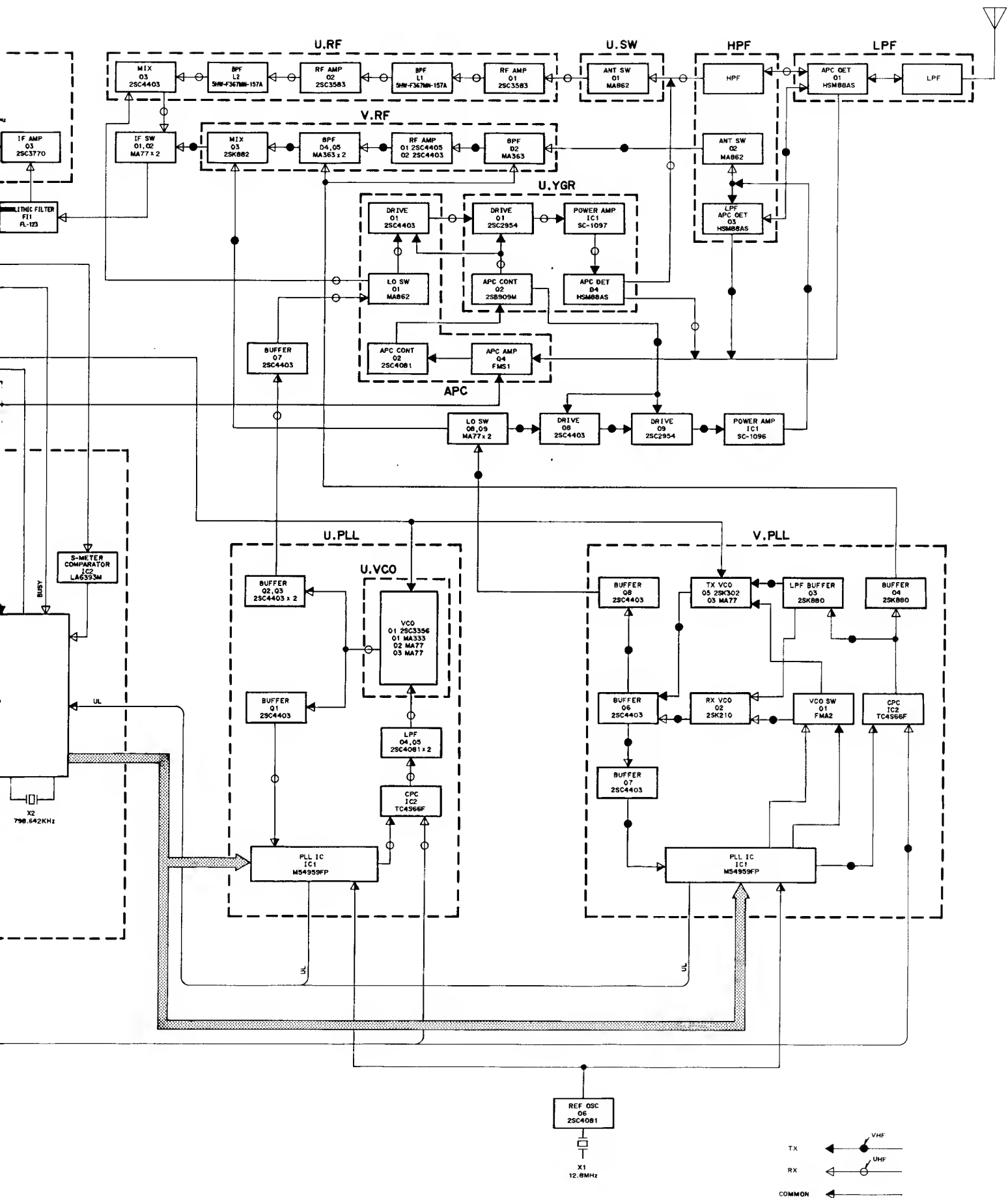

# SECTION 9 VOLTAGE DIAGRAMS

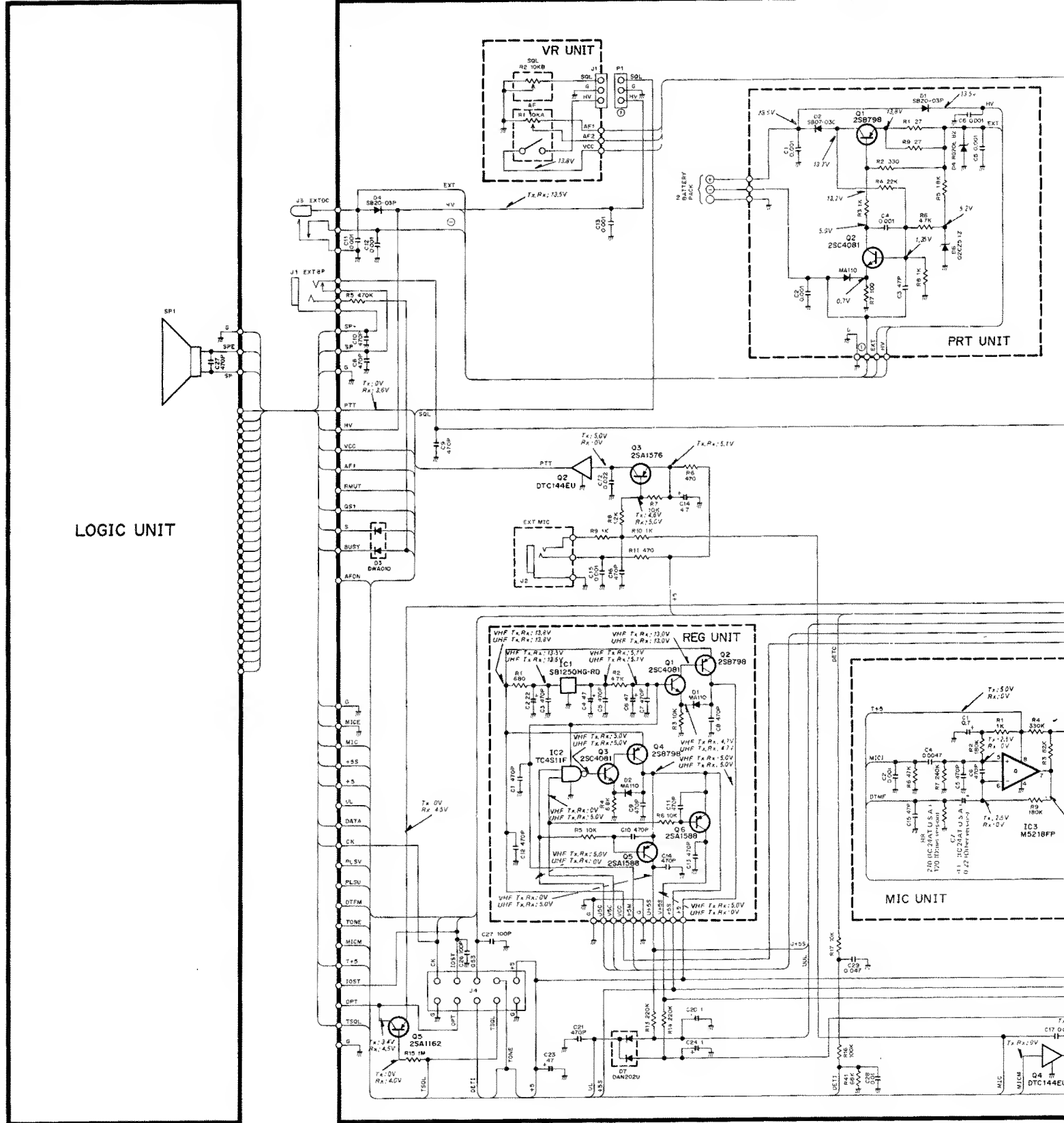

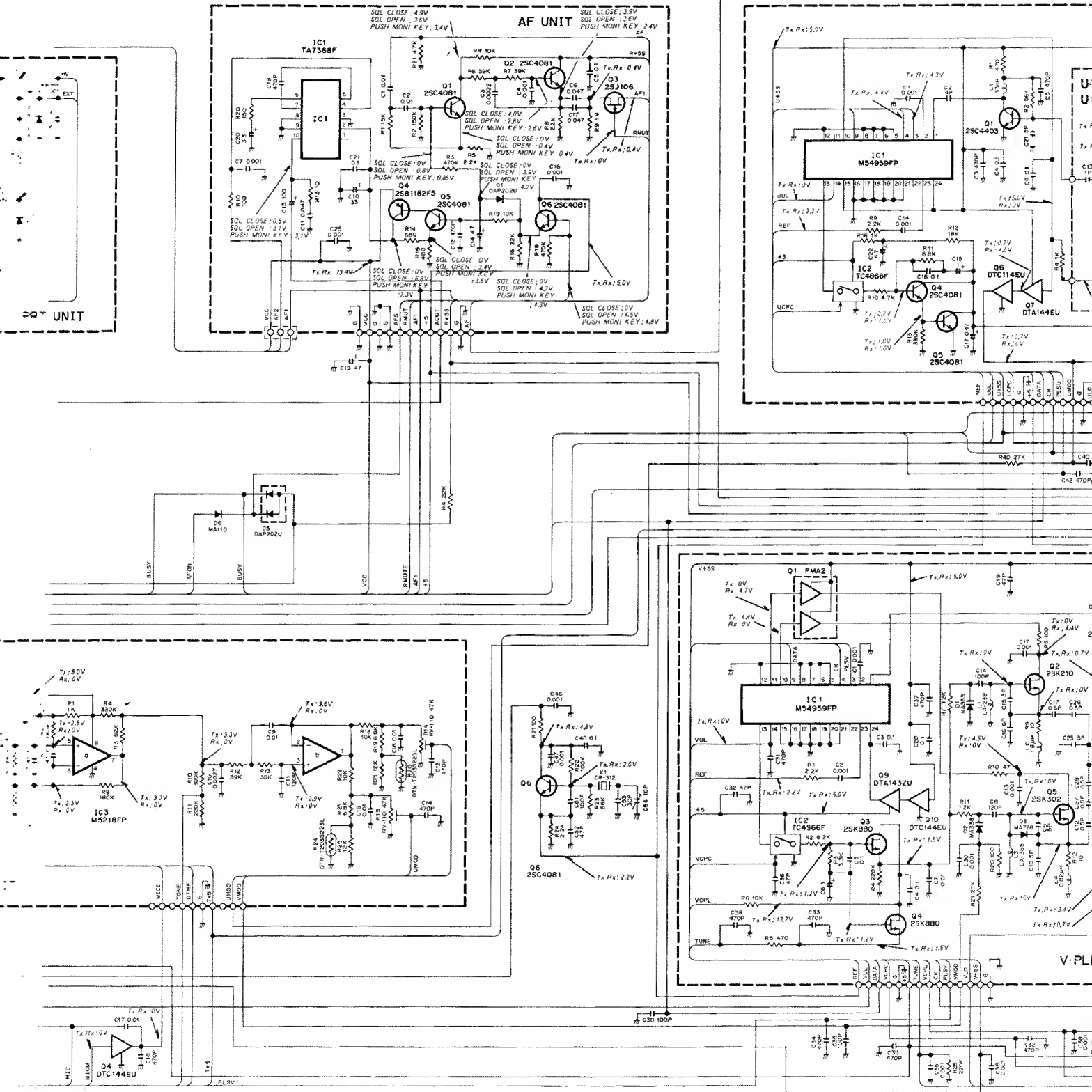

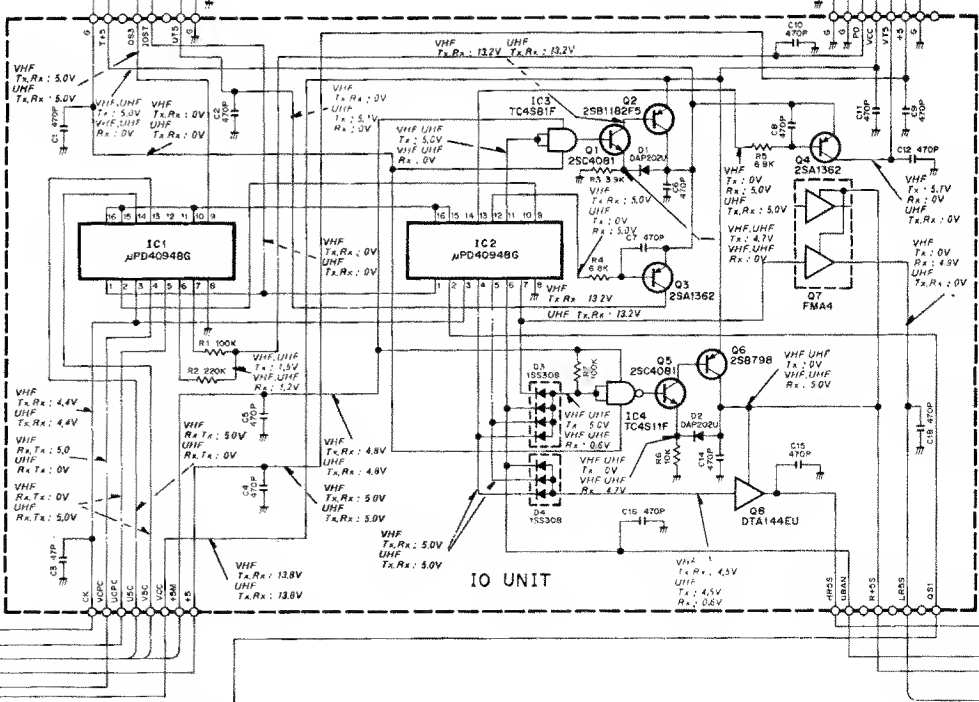
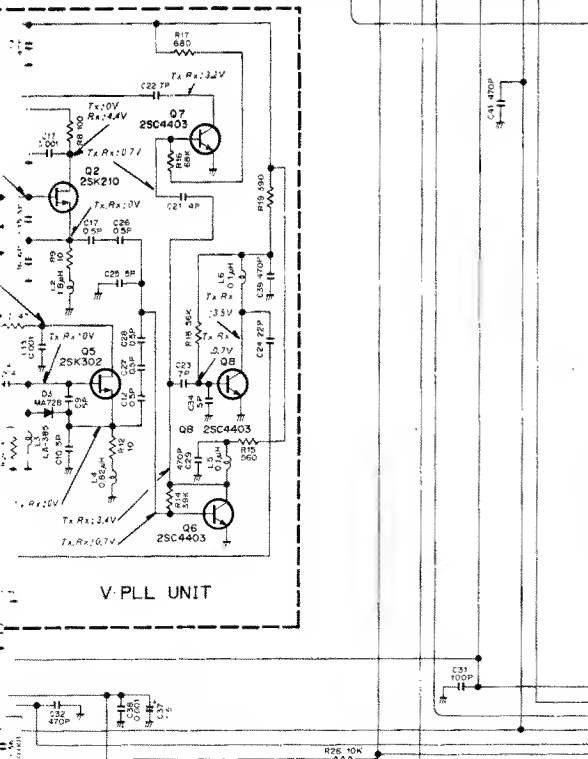
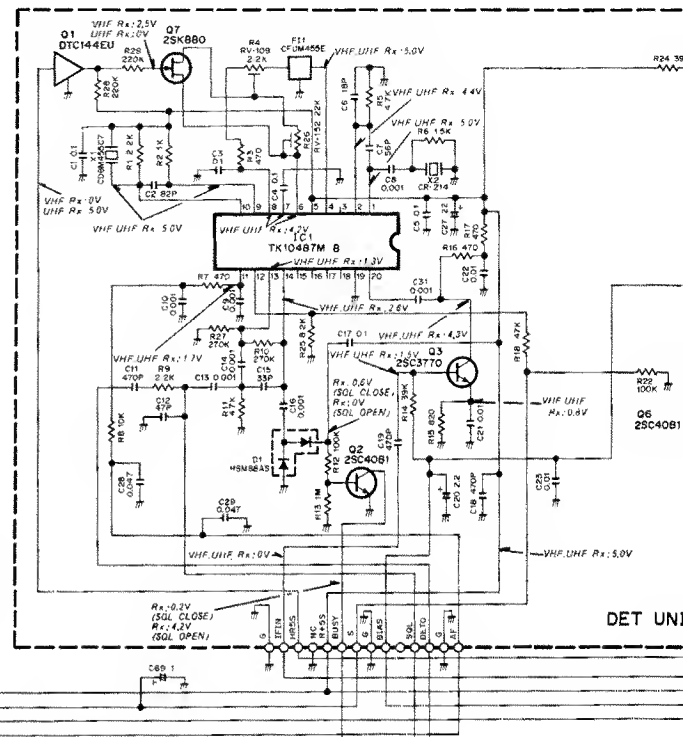
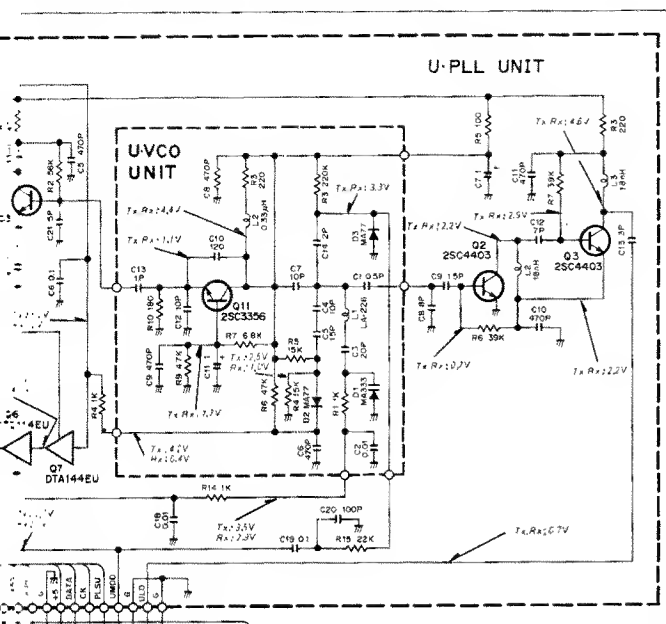

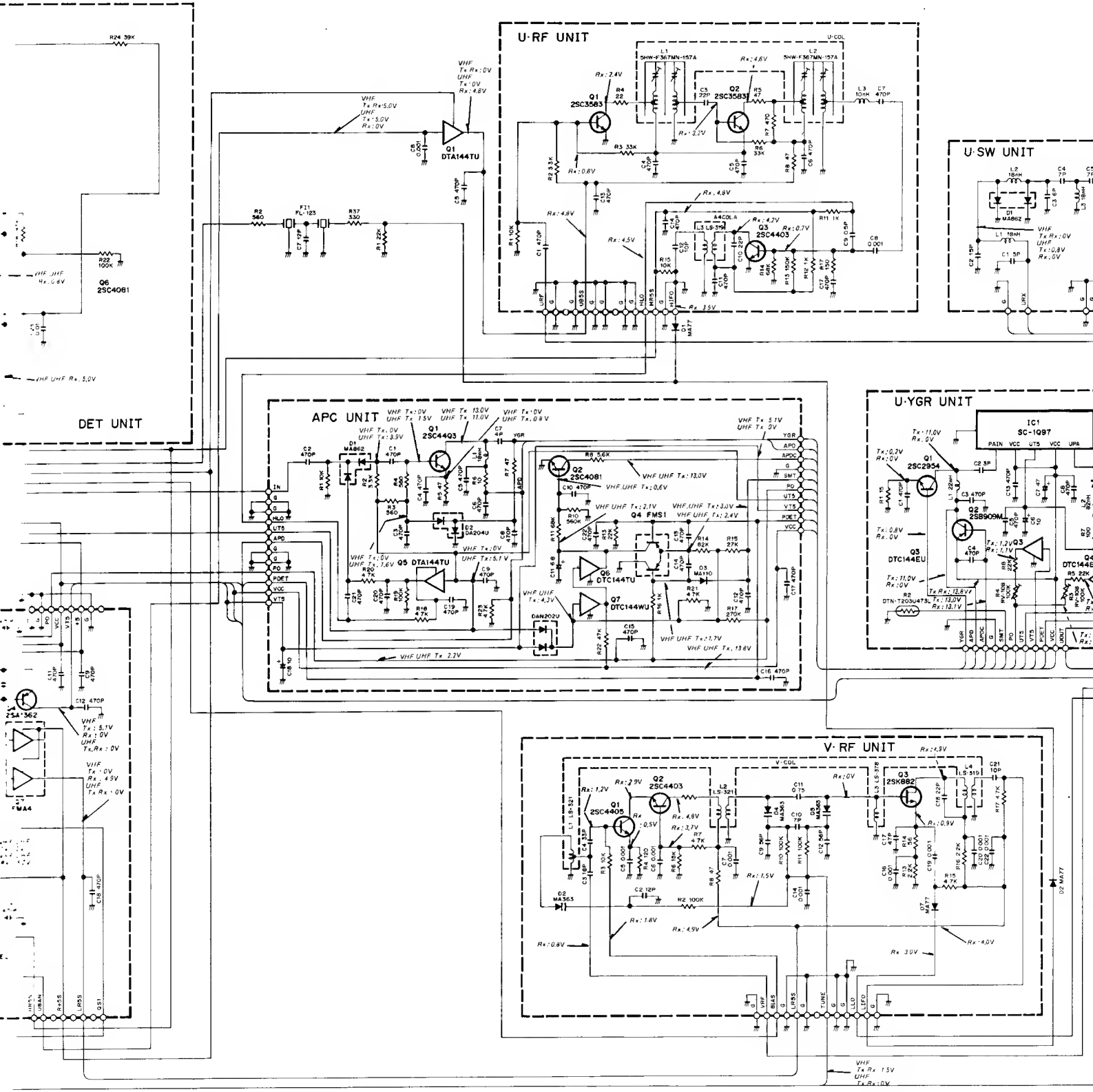

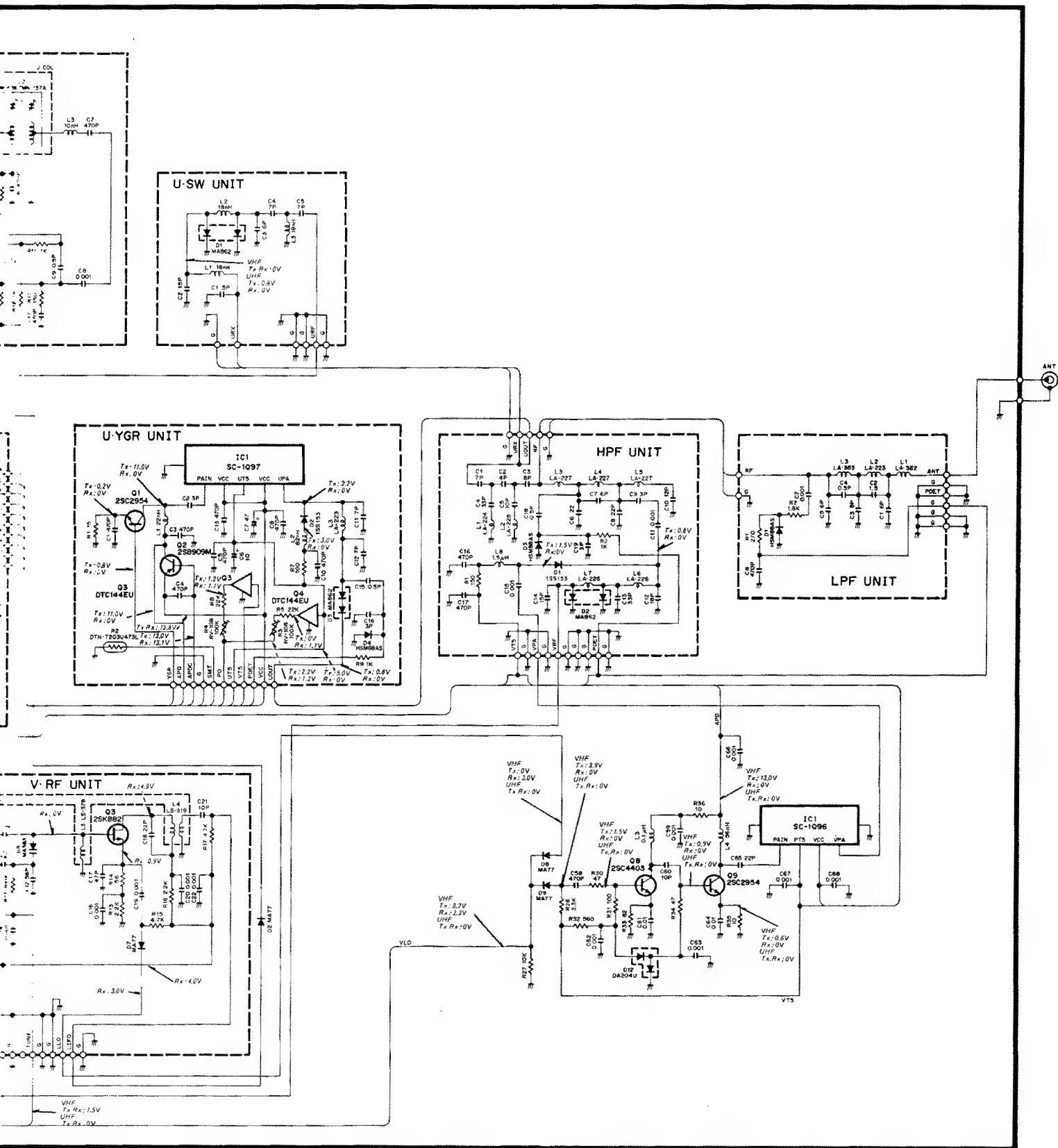

**LOGIC UNIT**

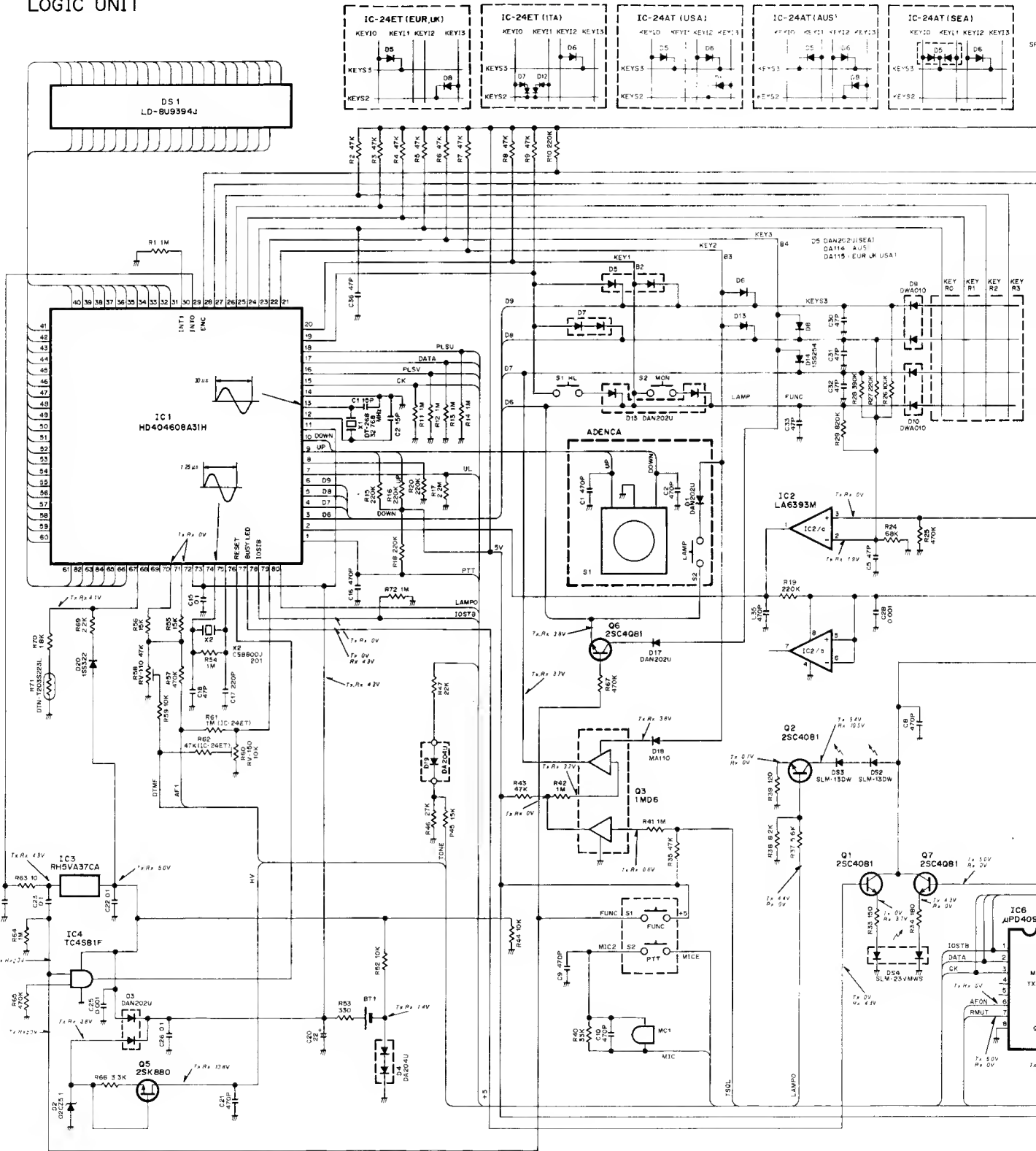



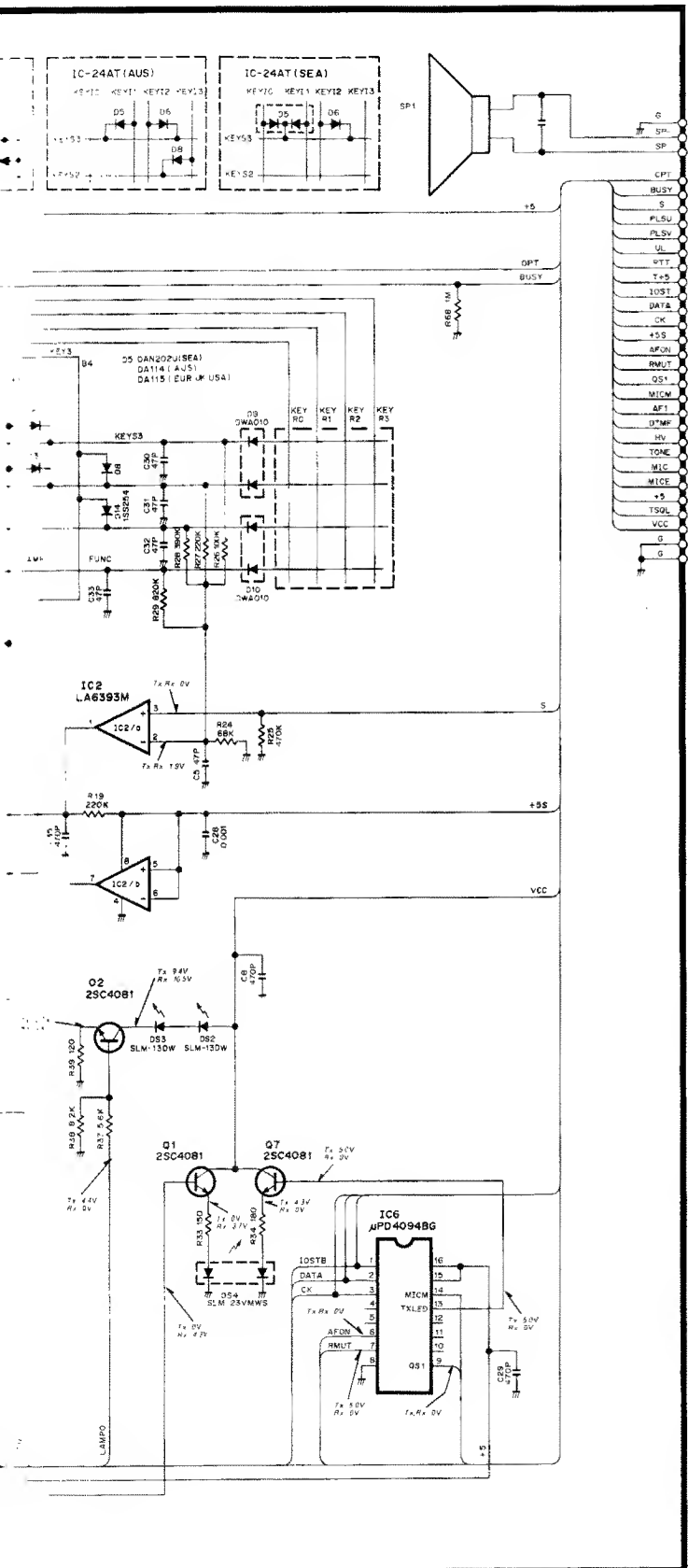

## Icom Inc.

6-9-16, Kamihigashi, Hirano-ku, Osaka 547, Japan

Phone: 06 793 5301

Fax : 06 793 0013

Telex : 05277822 ICOMTR J

### Icom America Inc.

<Corporate Headquarters>

2380 116th Avenue N.E., Bellevue, WA 98004, U.S.A.

Phone: (206) 454-8155

Fax : (206) 454-1509

Telex : 152210 ICOM AMER BVUE

<Customer Service>

Phone: (206) 454-7619

<Regional Customer Service Centers>

3150 Premier Drive, Suite 126, Irving, TX 75063, U.S.A.

Phone: (214) 550-7525

Fax : (214) 550-7423

1777 Phoenix Parkway, Suite 201, Atlanta, GA 30349, U.S.A.

Phone: (404) 991-6166

Fax : (404) 991-6327

### Icom Canada

A Division of Icom America Inc.

3071 #5 Road, Unit 9, Richmond, B.C., V6X 2T4, Canada

Phone: (604) 273-7400

Fax : (604) 273-1900

### Icom (Europe) GmbH

Communication Equipment

Himmelgeister Str. 100, 4000 Dusseldorf 1, W. Germany

Phone: 0211 346047

Fax : 0211 333639

Telex : 8588082 ICOM D

### Icom (Australia) Pty. Ltd.

Incorporated in Victoria

7 Duke Street, Windsor, Victoria, 3181, Australia

Phone: 03 529 7582

Fax : 03 529 8485

Telex : AA 35521 ICOM AS

### Icom (UK) Ltd.

Unit 9, Sea St., Herne Bay, Kent, CT6 8LD, U.K.

Phone: 0227 741741

Fax : 0227 360155

Telex : 965179 ICOM G

### Icom France S.a

120 Route de Revel, BP4063, 31029 Toulouse Cedex, France

Phone: 61. 20. 31. 49

Fax : 61. 34. 05. 91

Telex : 521515 ICOM FRA

Count on us!

Icom Inc.

6-9-16, Kamihigashi, Hirano-ku, Osaka 547, Japan

A-5082Y-S  
Printed in Japan  
Copyright © 1990 by Icom Inc.